

RECORD SERIAL NUMBER HERE

CONGRATULATIONS... You've just taken the first step to a healthier and stronger body. This home gym by Inspire Fitness offers the key to unlocking your body's potential. Regular strength training on a home gym has been shown to deliver a host of benefits including: increased muscle tone, decreased body fat, improved energy levels, a reduction in stress, and improved cardiac output. Once again, congratulations, you are on your way to improving your self image, overall health and quality of life.

BEFORE ASSEMBLING YOUR HOME GYM

CAUTION: Two people are required to complete steps 1-4 to ensure that the frame does not fall resulting in injury to the person assembling the gym.

IMPORTANT: Read this entire manual before attempting to build or use this machine. This manual contains step by step instructions for proper assembly.

Use the parts list included in this manual to verify that all parts are accounted for before assembly. If any parts are missing, contact the retailer of this home gym for replacement parts. Or, call Inspire Fitness at 714-738-1729.

Make sure that adequate room has been cleared before attempting to build your home gym. A rubber mat is recommended for use under your home gym to protect wood flooring or carpeting from damage during assembly and usage.

This home gym is intended for indoor use only. In addition, garages and screened in porches are not recommended due to high humidity or dust. Certain parts including guide rods can form rust in a humid environment, resulting in impaired function.

Service of your home gym should only be performed by an authorized Inspire Fitness retailer. Service performed by anyone else can result in loss of warranty. If you need help finding an authorized retailer, please contact us directly:

Inspire Fitness
4945 E. Hunter Ave.
Anaheim, CA 92807
Ph: 714-738-1729
Fx: 714-738-1728

www.inspirefitness.net

TABLE OF CONTENTS

Section Description	Page
Important Safety Instructions.....	1
Parts List.....	2
Assembly Instructions.....	4
Decal Reference.....	22
Decal Placement.....	24
Accessories.....	25
General Maintenance Information.....	26
Maintenance Schedule.....	27
Limited Warranty.....	28

IMPORTANT SAFETY INSTRUCTIONS

Please read this entire manual and familiarize yourself with all decals and warnings before using this home gym.

- **WARNING!** It is necessary to inspect this home gym regularly to maintain safety and proper function. Please use the maintenance schedule included towards the back of this manual. Immediately replace any and all defective or worn parts. Pay special attention to moving parts such as the cables and pulleys and connections to accessories. See General Maintenance section for complete details.
- Use this home gym for its intended purpose as described in this Operation Manual or the exercise chart. Do not use attachments not recommended by the manufacturer.
- Make sure bystanders are at least 5 feet away from the home gym while it is in use.
- Keep children off the home gym at all times.
- Keep the home gym away from walls and clear of any obstructions and furniture.
- Stop immediately if you experience shortness of breath, pain, or dizziness during your workout. Inspire Fitness strongly recommends consulting your doctor before starting an exercise program.

TOOLS REQUIRED FOR ASSEMBLY

- Standard socket set (including 13mm, 16mm & 17mm sockets)
- 13mm wrench
- 16mm wrench
- 17mm wrench
- 19mm wrench
- Tape Measure
- Rubber Mallet
- Adjustable wrench
- 5mm Allen wrench – supplied
- 6mm Allen wrench – supplied

PARTS & HARDWARE LIST

Item	Part NO.	Parts Description	Qty
1	GM875-100-001PZ	Main Base	1
2	GM872-300-005	Bottom Shroud Plate	1
3	GM695-381-001	Guide Rod	2
4	GM692-501-003PZ	Selector Stem / Top Weight	1
5	W5	Weight Plate	20
6	GM692-881-003	Rubber Donut	2
7	GM692-380-001	Weight Stack Riser	2
8	GM692-500-002PZ	Adjustable Pulley	1
9	0110-412-02	Hex Flange Nut	1
10	GM692-500-004PZ	Weight Selector Pin	1
11	GM875-230-001PZ	Main Upright	1
12	GM875-110-001	Rear Base	1
13	GM875-280-001	Base Brace, L	1
14	GM875-290-001	Base Brace, R	1
15	GM875-200-001PZ	Upright Support	2
16	GM875-240-001PZ	Top Beam Assembly	1
17	GM875-340-001	Top Shroud Plate	1
18	GM875-210-001	Center Upright Brace	1
19	GM875-220-001	Upper Swivel Pulley Bracket	2
20	GM875-260-001PZ	Center Pulley Assembly	1
21	GM875-270-001PZ	Rear Upper Pulley Assembly	1
22	GM695-320-012PZ	Swivel Pulley	6
23	GM875-300-001PZ	Seat Frame	1
24	GM875-320-001PZ	Linkage Bar	3
25	GM875-330-001PZ	Linkage Bar, Pin	1
26	GM875-310-001	Back Pad Mount	1
27	GM875-400-001	Seat Pad	1
28	GM875-400-002	Back Pad	1
29	SHC2	Shroud	1
30	GM660-820-001	Short D-Handle	4
31	GM875-351-001PZ	Floating Pulley Assembly	2
32	GM872-381-005	Shroud Bracket	2
33	GM872-561-004	T Pins	6
34	GM880-101-016	Cable "U" Bracket	6
35	0200-070-082	Spring Clip	6
36	0113-206-138A	M6 x 12 Button Head Bolt	6
37	GM880-201-032	M6 T-Nut	6
38	GM851-881-009	Plastic Ball	6
39	GM875-500-001	Upper Cable Assembly	1
40	GM875-500-002	Lower Cable Assembly	2
41	GM692-880-001	3 1/2" Pulley	2
42	GM870-880-001	4 1/2" Pulley	2
43		Multi "D" Ring Handle	2

Item	Part NO.	Parts Description	Qty
44	0111-010-208	Bolt, M10 x 20mm L	8
45	0111-010-258	Bolt, M10 x 25mm L	2
46	0111-010-403	Bolt, M10 x 40mm L	2
47	0111-010-458	Bolt, M10 x 45mm L	2
48	0111-010-508	Bolt, M10 x 50mm L	4
49	0111-010-558	Bolt, M10 x 55mm L	2
50	0111-010-758	Bolt, M10 x 75mm L	2
51	0111-010-858	Bolt, M10 x 85mm L	4
52	0111-010-908	Bolt, M10 x 90mm L	2
53	0111-110-058	Bolt, M10 x 110mm L	2
54	0111-010-125	Bolt, M10 x 125mm L	2
55	0111-010-218	Bolt, M10 x 205mm L	4
56	0113-210-258	Bolt, M10 x 25mm L (Flat Head)	7
57	0113-210-758	Bolt, M10 x 75mm L (Button Head)	1
58	0113-208-258	Bolt, M8 x 25mm L (Button Head)	8
60	GM695-561-015	Bolt, M12 x 65mm L	6
61	0116-012-008	M12 Flat Washer	6
62	0116-010-008	M10 Flat Washer	70
63	0116-008-028	M8 Flat Washer	16
64	0110-712-008	M12 Lock Nut	6
65	0110-710-008	M10 Lock Nut	29
66	0110-708-028	M8 Lock Nut	8
67	0113-710-458	Bolt, M10 x 45mm L	2
68	0111-010-018A	M10 x 100mm L	2
69	0110-010-108	M10 Lock Nut	2
70		6mm Wrench	1

CABLE CHART



LP3 MAIN CABLE
GM872-500-005

UPPER CABLE (5,920mm)
GM875-500-001



LP3-M5 CABLE
GM872-500-006

MIDDLE CABLE (4,670mm)
GM875-500-002

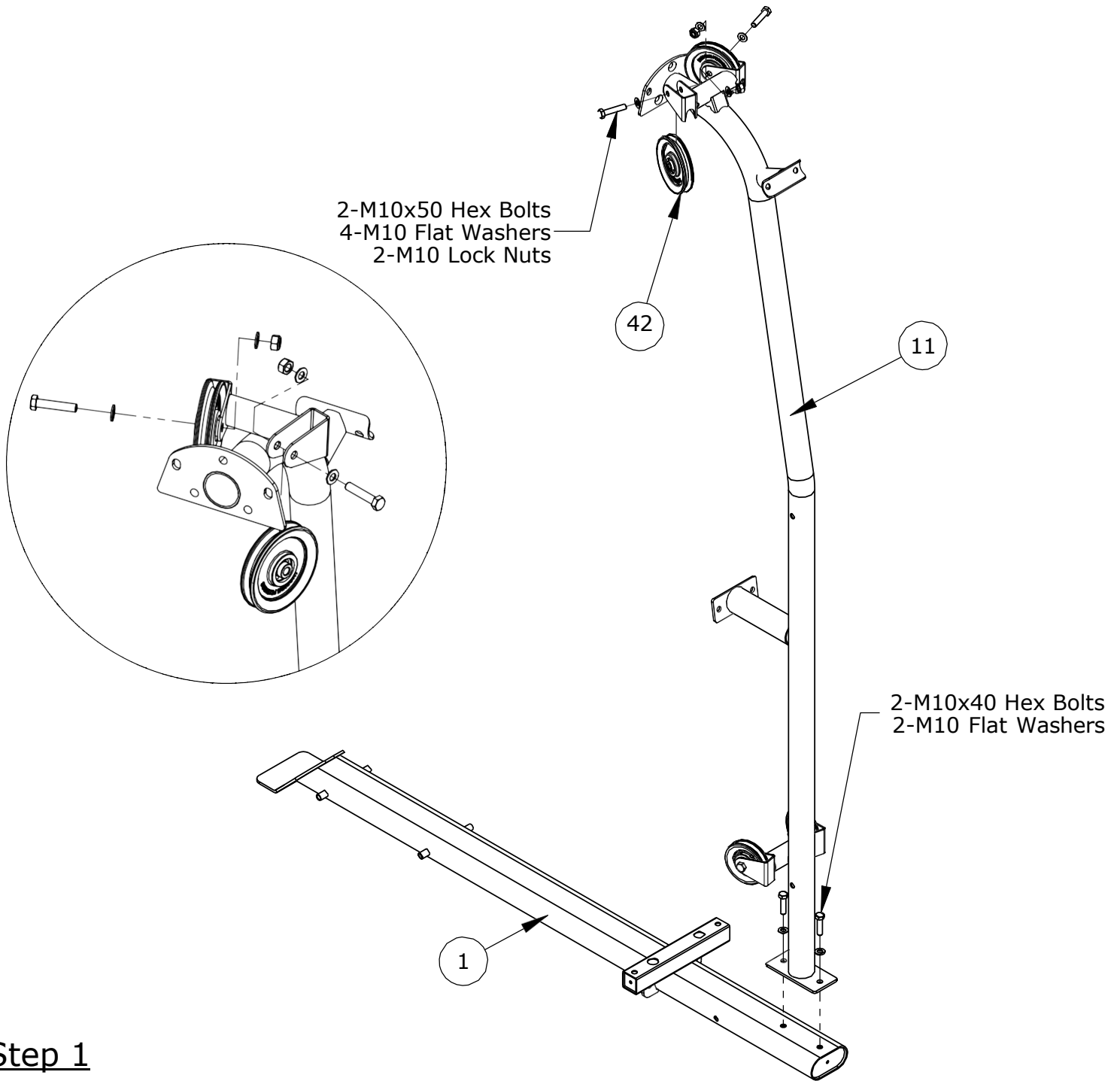

Step 1

DO NOT TIGHTEN ANY HARDWARE IN THIS STEP

- A Attach the Main Upright (11) to the Main Base (1) using 2- M10x40 Hex bolts (46) and 2- M10 Washers (62).
- B Attach 2- 4-1/2" Pulleys (42) to the Main Upright (11) using 2- M10x50 Hex bolts (48), 4- M10 Washers (62), and 2- M10 Lock Nuts (65).

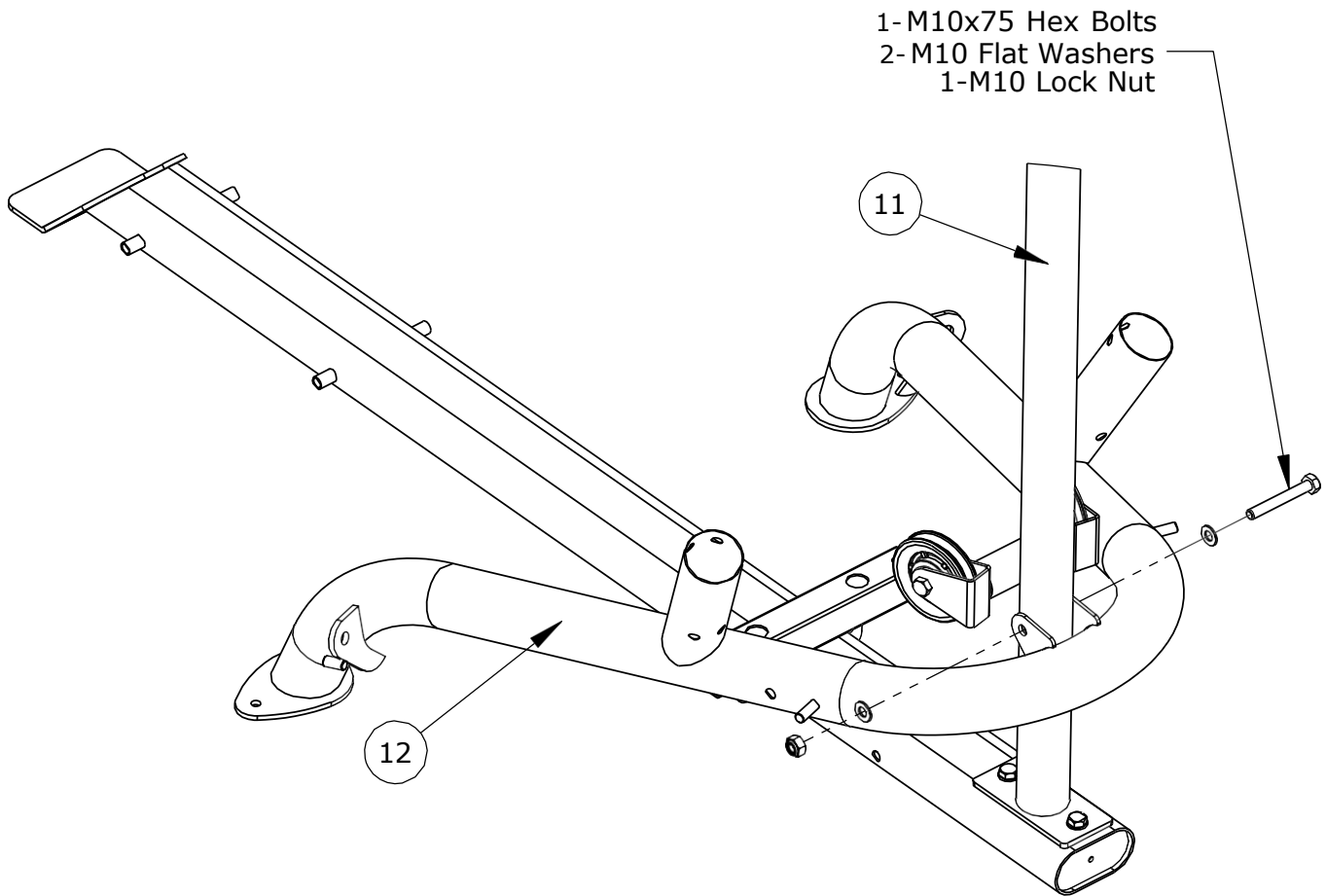

Step 2

DO NOT TIGHTEN ANY HARDWARE IN THIS STEP

- A Attach the Rear Base (12) to the Main Upright (11) using 1- M10x75 Hex bolts (50), 2- M10 Washers (62), and 1- M10 Lock Nuts (65).

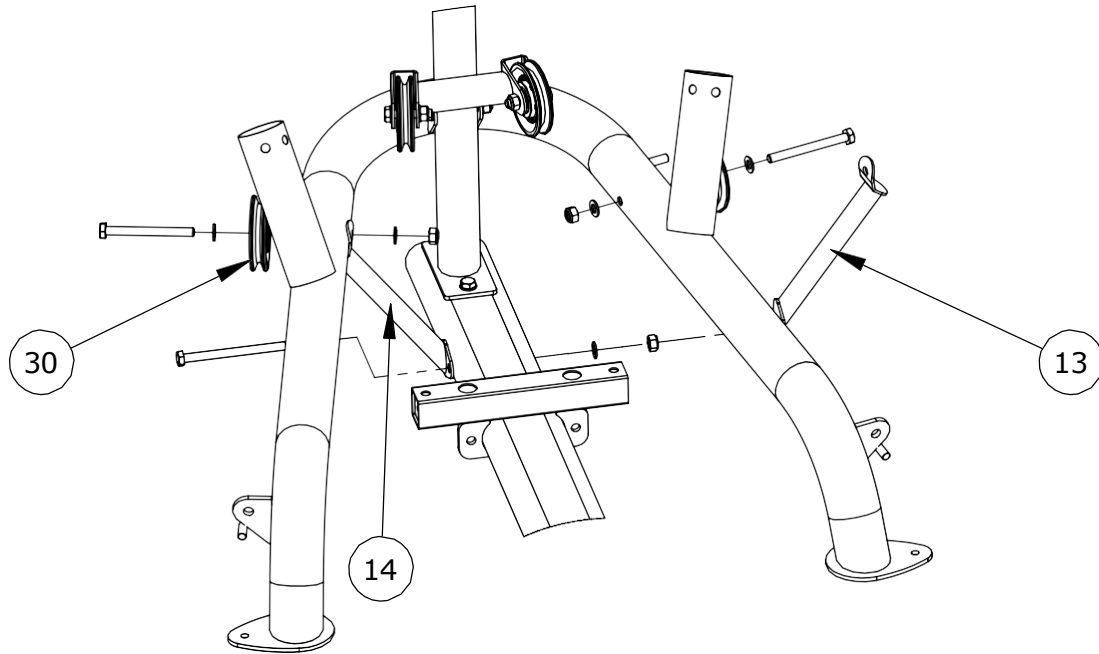

2-M10x110 Hex Bolts
4-M10 Flat Washers
2-M10 Lock Nut

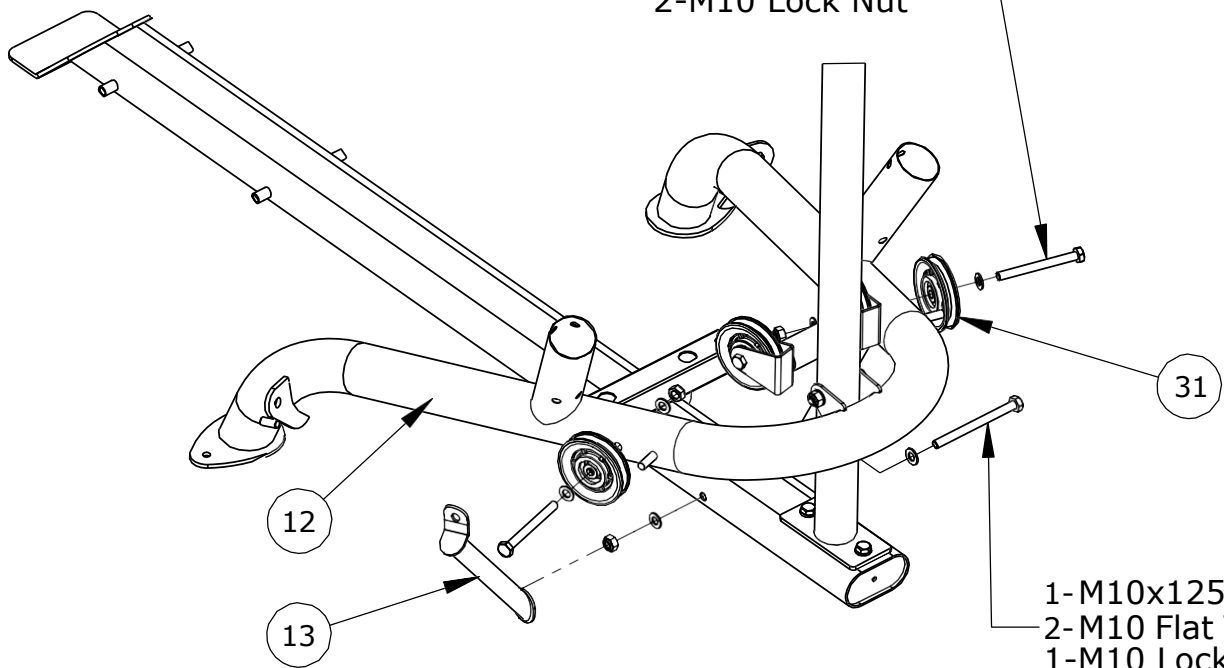

1- M10x125 Hex Bolts
2- M10 Flat Washers
1-M10 Lock Nut

Step 3

DO NOT TIGHTEN ANY HARDWARE IN THIS STEP.

- A Attach the Left Base Brace (13) and Right Base Brace (14) using a M10x125 Hex Bolt (54), 2- M10 Washers (62), and 1- M10 Lock Nut (65).
- B Attach a 3-1/2" Pulley (41) to both sides of the Rear Base (12) using 2- M10x110 Hex bolts (53), 4- M10 Washers (62), and 2- M10 Lock Nuts (65).

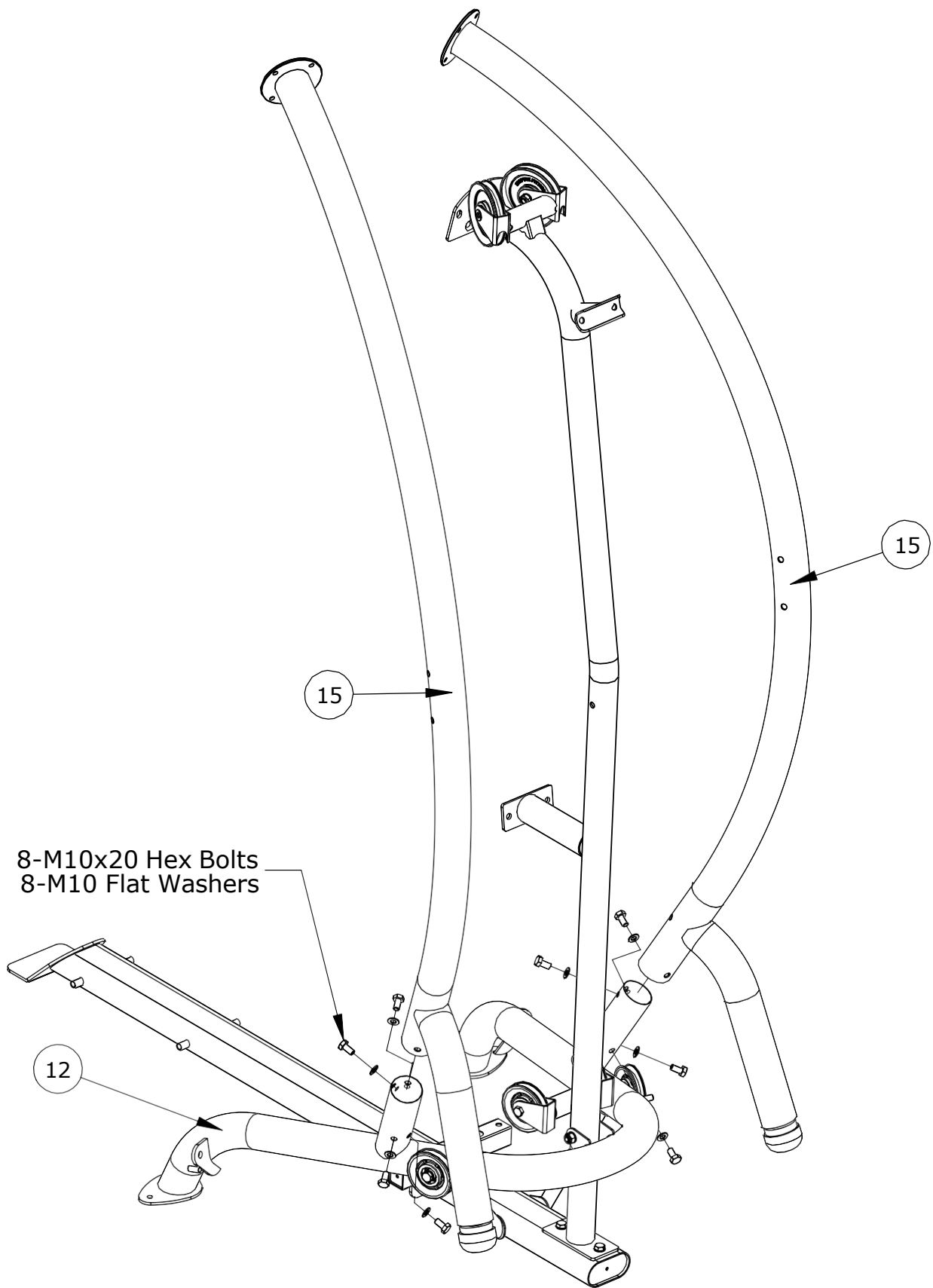

Step 4

DO NOT TIGHTEN ANY HARDWARE IN THIS STEP

- A Insert the Upright Supports (15) to the Rear Base (12) using 8- M10x20 Hex bolts (44) and 8- M10 Washers (62).

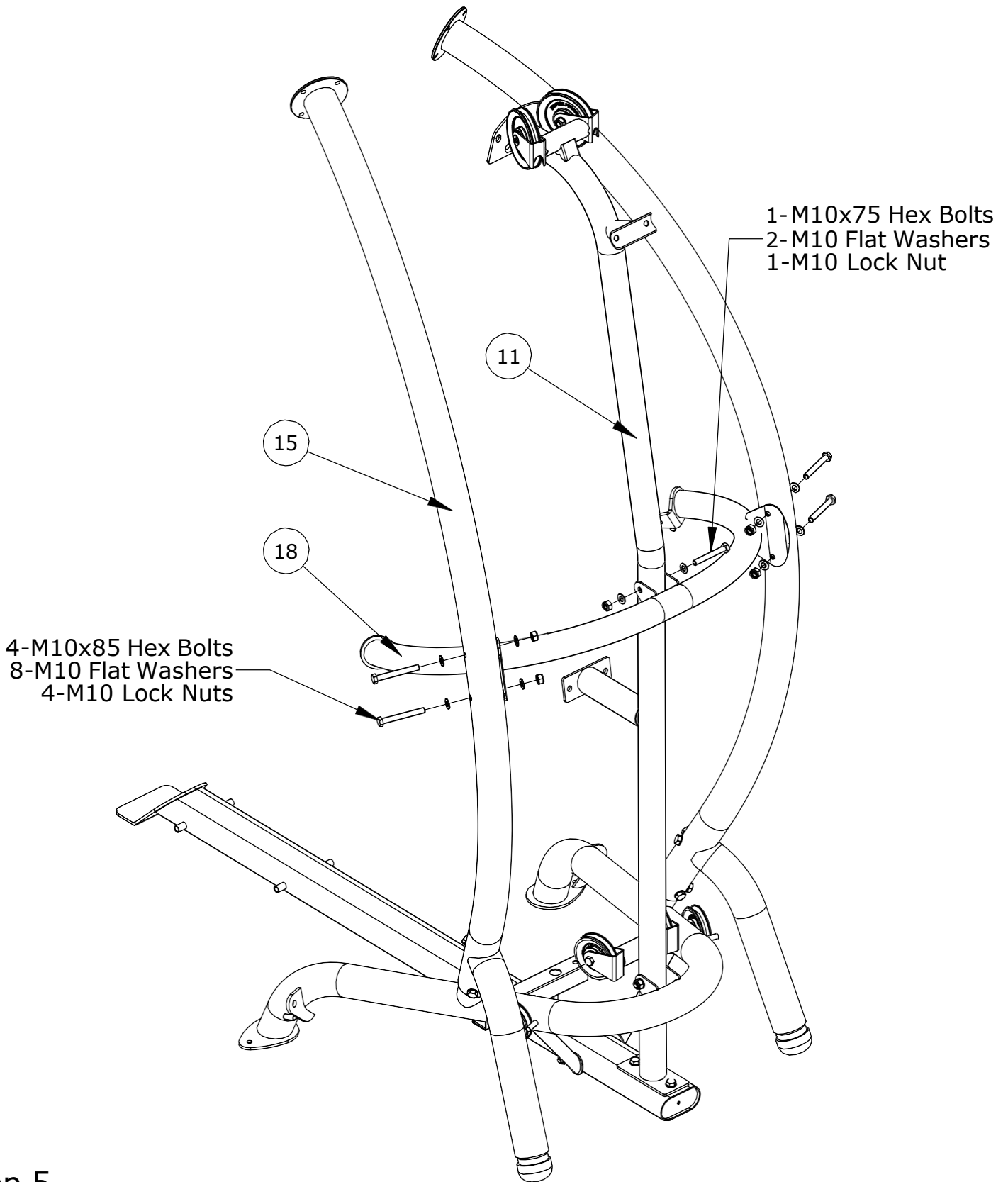

Step 5

DO NOT TIGHTEN ANY HARDWARE IN THIS STEP

- A Attach the Center Upright Brace (18) to the Main Upright (11) using 1- M10x75 Hex bolts (50), 2- M10 Washers (62), and 1- M10 Lock Nuts (65). Then attach the Center Upright Brace (18) to the Upright Supports (15) using 4- M10x85 Hex bolts (51), 8- M10 Washers (62), and 4- M10 Lock Nuts (65).

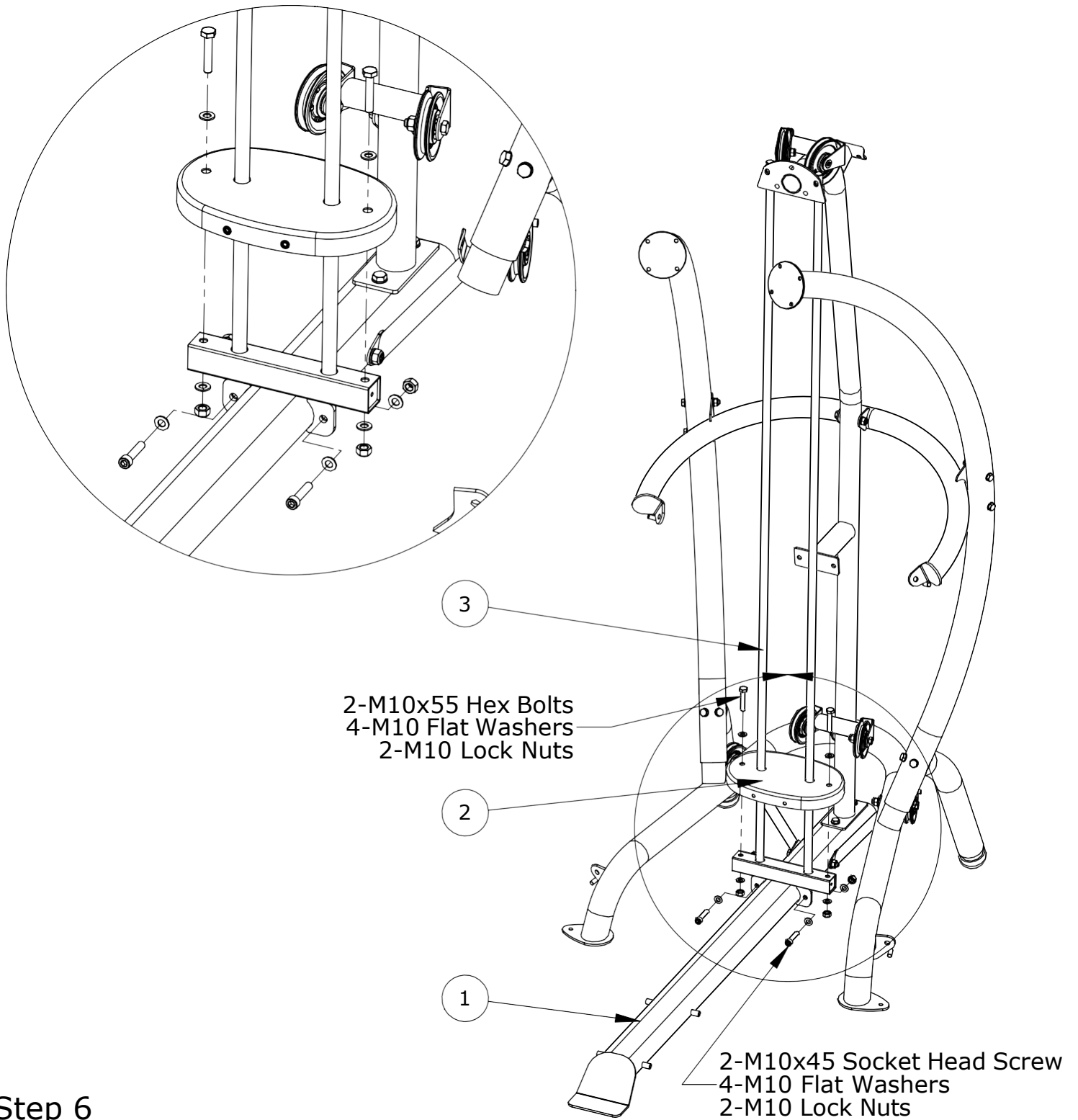

Step 6

DO NOT TIGHTEN ANY HARDWARE IN THIS STEP

- A Attach Guide Rods (3) to the Main Base (1) using 2- M10x45 Sock Head Screws (XX), 4- M10 Washers (62), and 2- M10 Lock Nuts (65).
- B Slide the Bottom Shroud Plate (2) onto the Guide Rods (3) and use 2- M10x55 Hex bolts (49), 4- M10 Washers (62), and 2- M10 Lock Nuts (65) to secure the shroud plate.

NOTE: Verify that the 2 pin holes at the front of the Bottom Shroud Plate (2) are facing the front of the machine and that the single hole is facing the back of the unit.

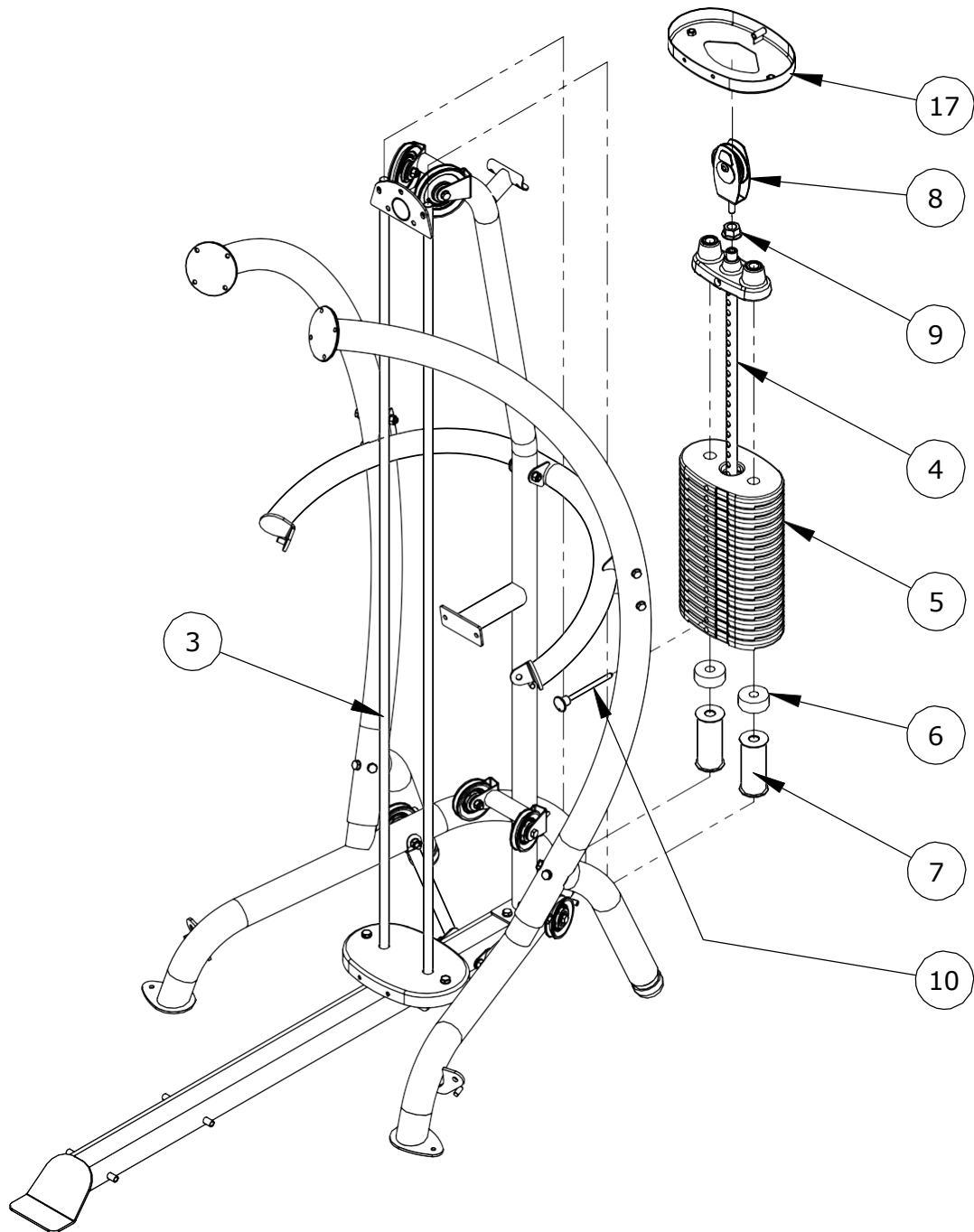

Step 7

DO NOT TIGHTEN ANY HARDWARE IN THIS STEP

- A Slide the Weight Stack Risers (7), Rubber Donuts (6), and 15 Weight Plates (5) onto the Guide Rods (3). Make sure the weight sticker cut out is facing the front of the machine. If a 200 lb stack will be used then the Weight Stack Risers (7) must be removed.
- B Screw the Top Weight Pulley Bracket Assembly (8) onto the Selector Stem at the Top Weight (4). Thread all the way down but do not tighten yet. Slide the Top Weight Assembly (4) onto the Guide Rods (3) so the 3-1/2" pulley is positioned between the two Guide Rods (3).
- C Insert a Weight Pin (10) into the stack.
- D Attach weight stack stickers.

NOTE: Verify that the 2 pin holes at the front of the Top Shroud Plate (17) are facing the front of the machine and that the single hole is facing the back of the unit.

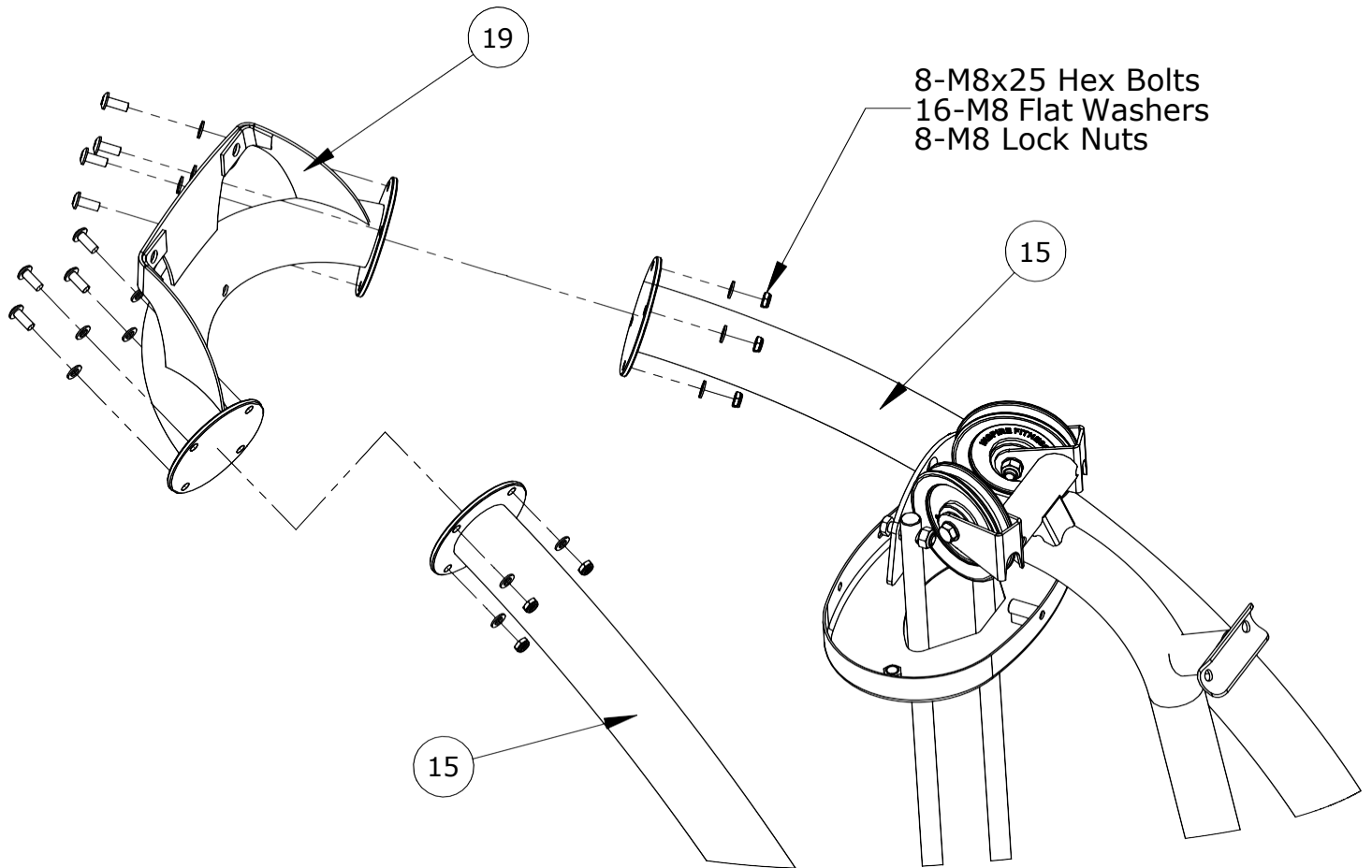

Step 8

DO NOT TIGHTEN ANY HARDWARE IN THIS STEP

- A Attach the Upper Swivel Pulley Bracket (19) to the Upright Supports (15) using 8- M8x25 Button Head Bolts (58), 16- M8 Washers (63), and 8- M8 Lock Nuts (66).

NOTE: *It may be necessary to tighten some of the bolts in order to install the rest of the bolts. If any bolts are tightened down they must be loosened before proceeding to the next step.*

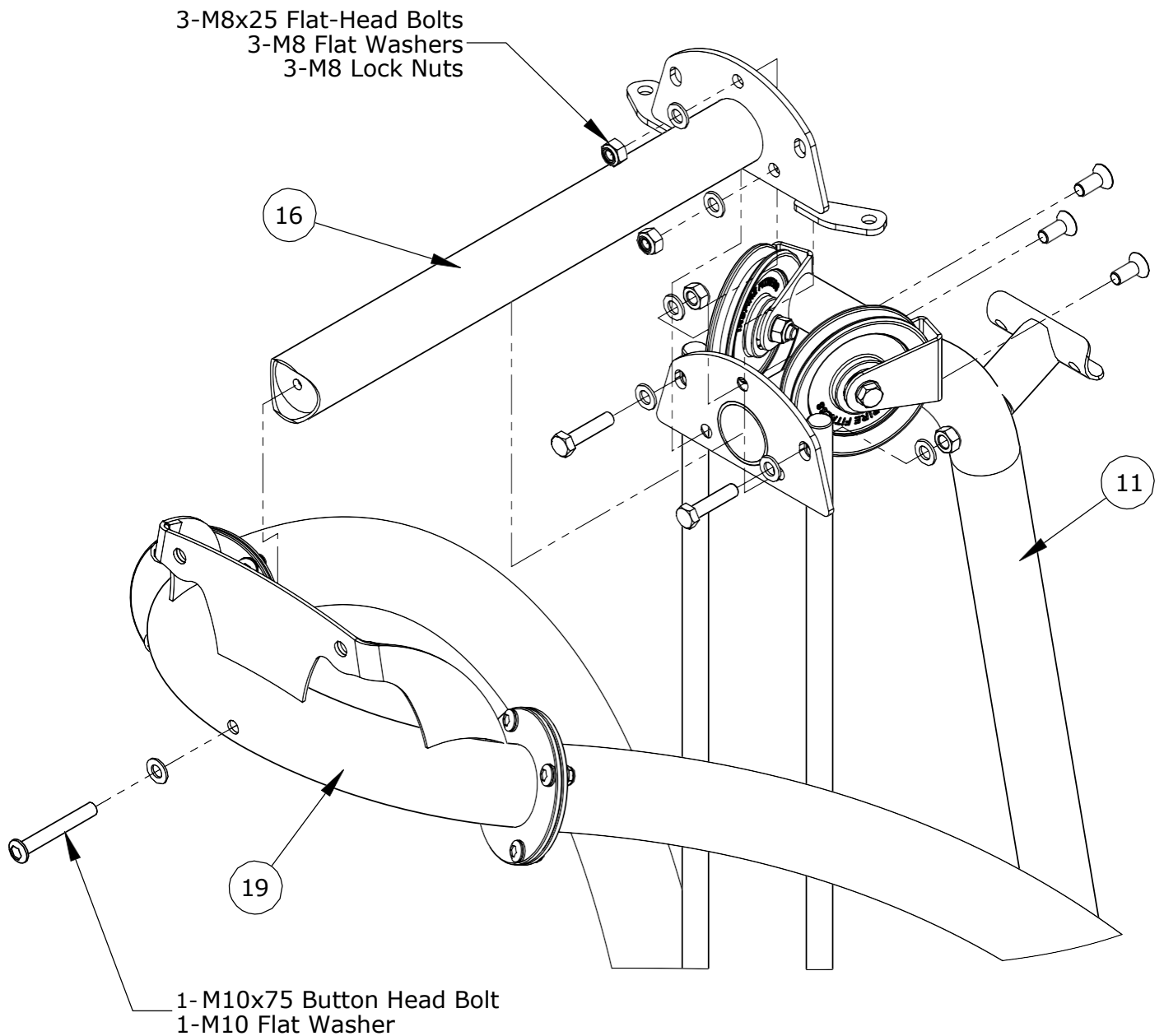

Step 9

DO NOT TIGHTEN ANY HARDWARE IN THIS STEP

- A Attach the Top Beam Assembly (16) to the Upper Swivel Pulley Bracket (19) using a M10x75 Button Head Bolt (57) and a M10 Flat Washer (62).
- B Slip in the Top Beam Assembly (16) onto the Main Upright (11) using 3- M10x25 Flat Head Bolts (56), 6- M10 Washers (62), and 3- M10 Lock Nuts (65). The Flat Head Bolts (56) must be inserted from back of the unit to the front.
- C Bolt the top of the Guide Rods (3) to the Main Upright (11) and Top Beam Assembly(16) using 2- M10x45 Hex bolts (47), 4- M10 Washers (62), and 2- M10 Lock Nuts (65).

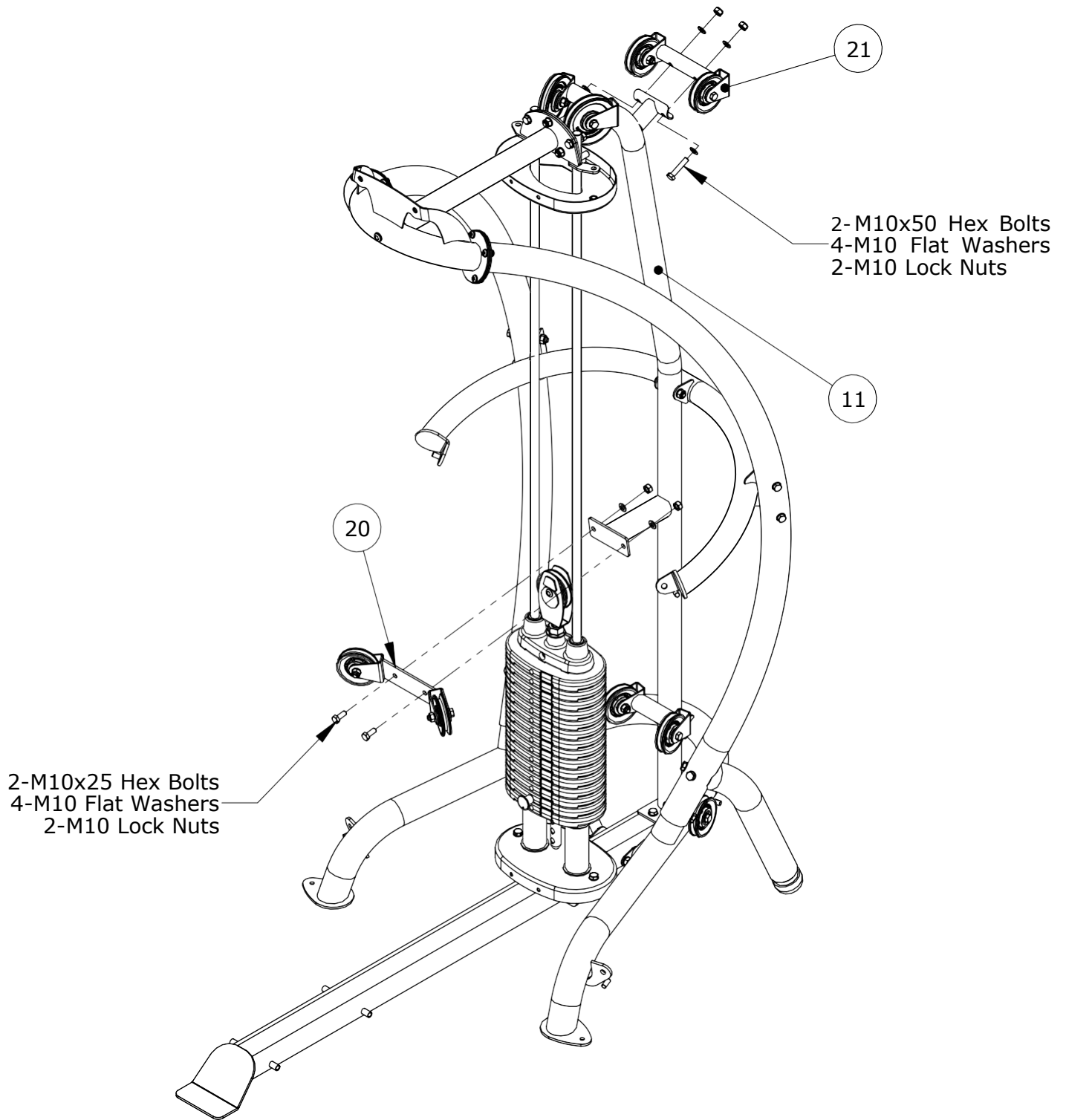

Step 10

- A Attach the Rear Upper Pulley Assembly (21) to the Main Upright (11) using 2- M10x50 Hex Bolts (48), 4- M10 Washers (62), and 2- M10 Lock Nuts (65).
- B Attach the Center Pulley Assembly (20) to the Main Upright (11) using 2- M10x25 Hex bolts (45), 4- M10 Washers (62), and 2- M10 Lock Nuts (65).

Tighten all hardware from steps 1-10 now.

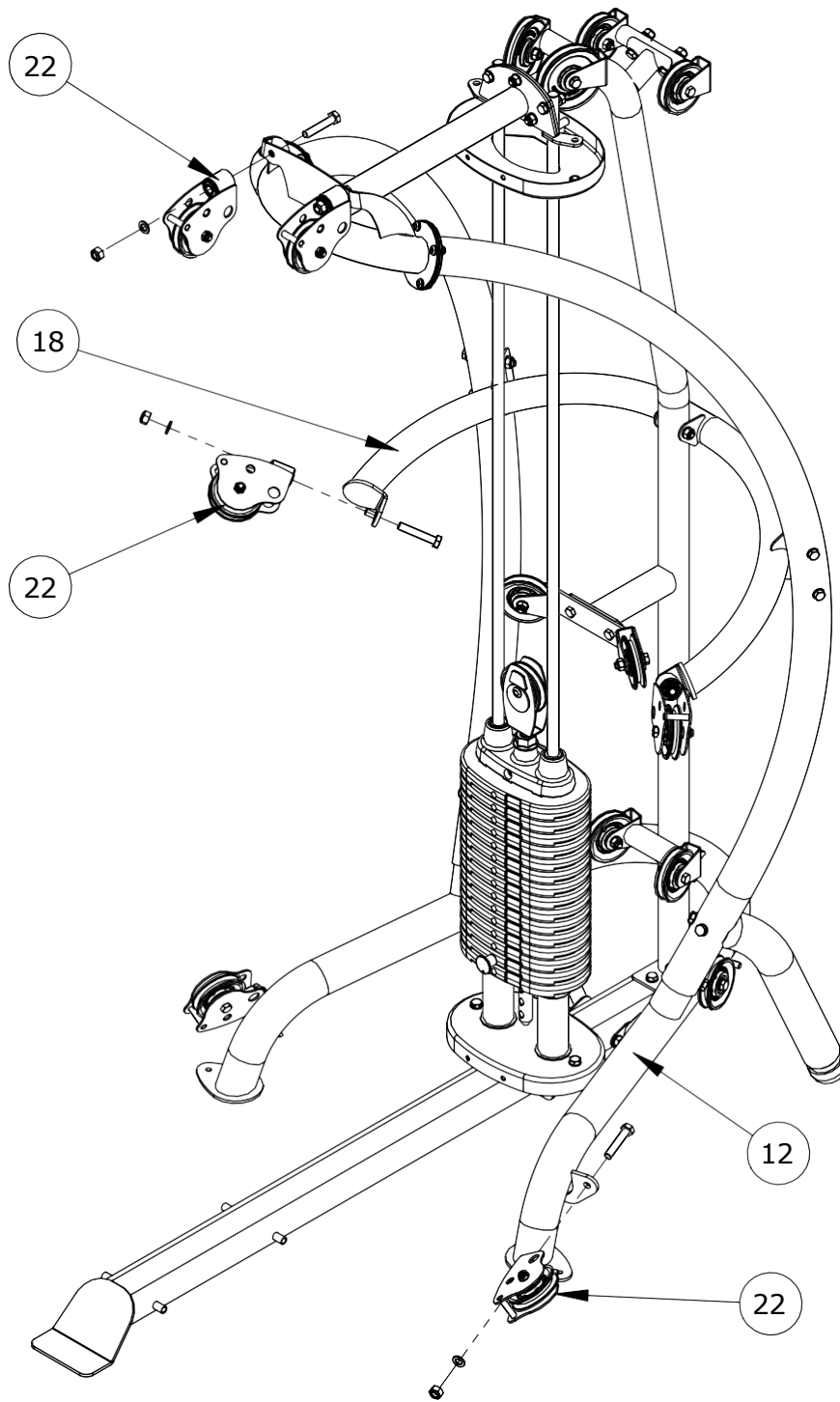

Step 11

- A Attach 2 Swivel Pulleys (22) to the Upper Swivel Pulley Bracket (19) using 2- M12x65 Hex bolts (60), 1- M12 Washers (61), and 2- M12 Lock Nuts (64).
- B Attach 2 Swivel Pulleys (22) to the Center Upright Base (18) using 2- M12x65 Hex bolts (60), 1- M12 Washers (61), and 2- M12 Lock Nuts (64).
- C Attach 2 Swivel Pulleys (22) to the Rear Base (12) using 2- M12x65 Hex bolts (60), 1- M12 Washers (61), and 2- M12 Lock Nuts (64).

NOTE: The M12 bolts must be installed in the direction shown in the above drawing such that the head of the bolt faces the back of the unit.

Tighten hardware now.

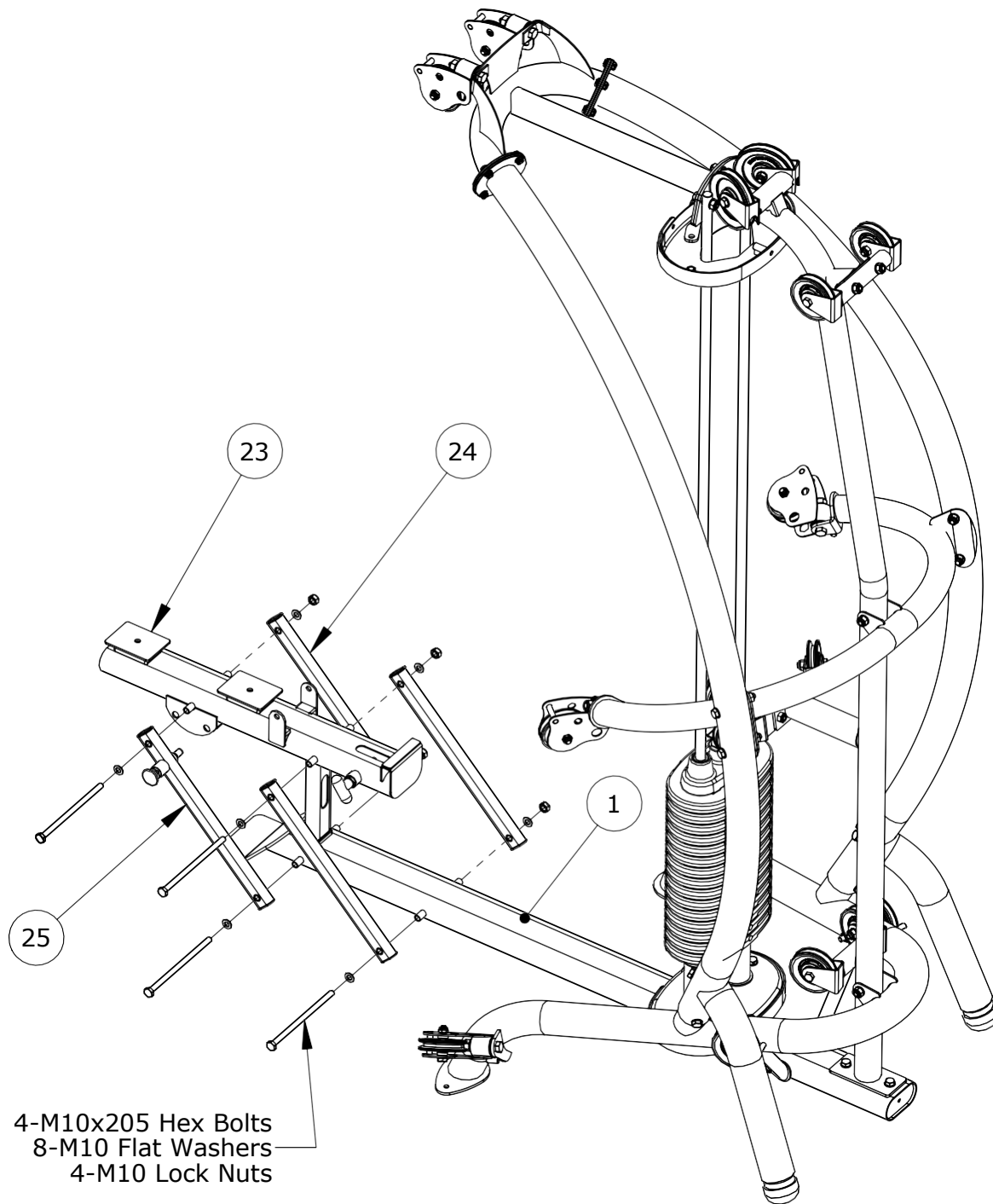

Step 12

- A Attach Pinned Linkage Bar (25) to the front, left side of the Main Base (1) using 1- M10x205 Hex bolts (55) and 1- M10 Washers (62).
- B Attach 3 Linkage Bars (24) to the Main Base (1) using 1- M10x205 Hex bolt (55), 3- M10 Washers (62), and 3- M10 Lock Nuts (65).
- C Attach the Seat Frame (23) to the Linkages (24, 25) using 2- M10x205 Hex bolts (55), 4- M10 Washers (62), and 2- M10 Lock Nuts (65).

Tighten all 4 screws securely then loosen the nuts by $\frac{1}{2}$ a turn. If the seat is binding and too difficult to adjust then it may be necessary to loosen the nuts more. However, the bolts must not be too loose.

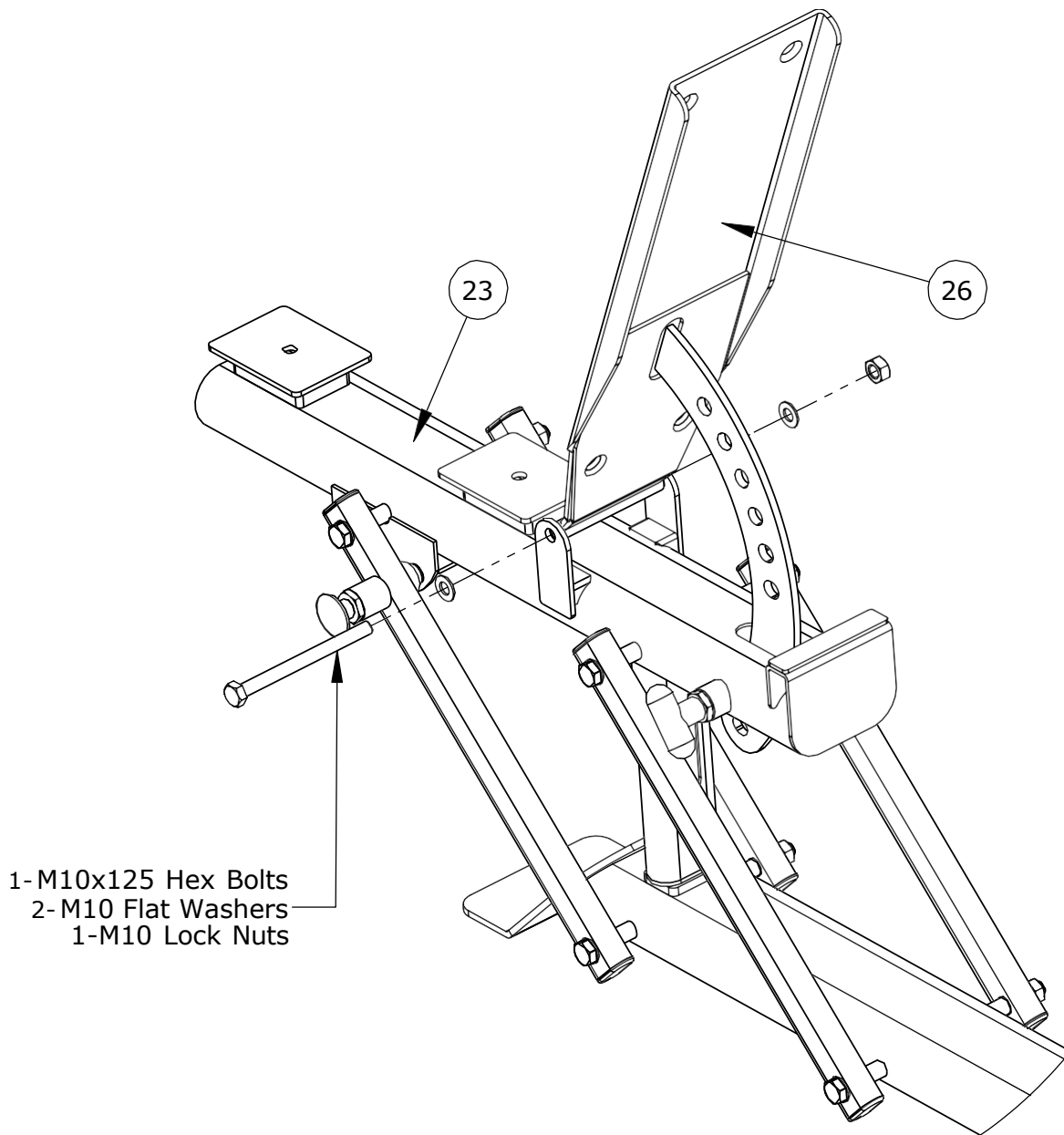

Step 13

A Attach the Back Pad Mount (26) to the Seat Frame (23) using 1- M10x125 Hex bolt (54), 2- M10 Washers (62), and 1- M10 Lock Nut (65).

Do not over tighten the hardware in this step.

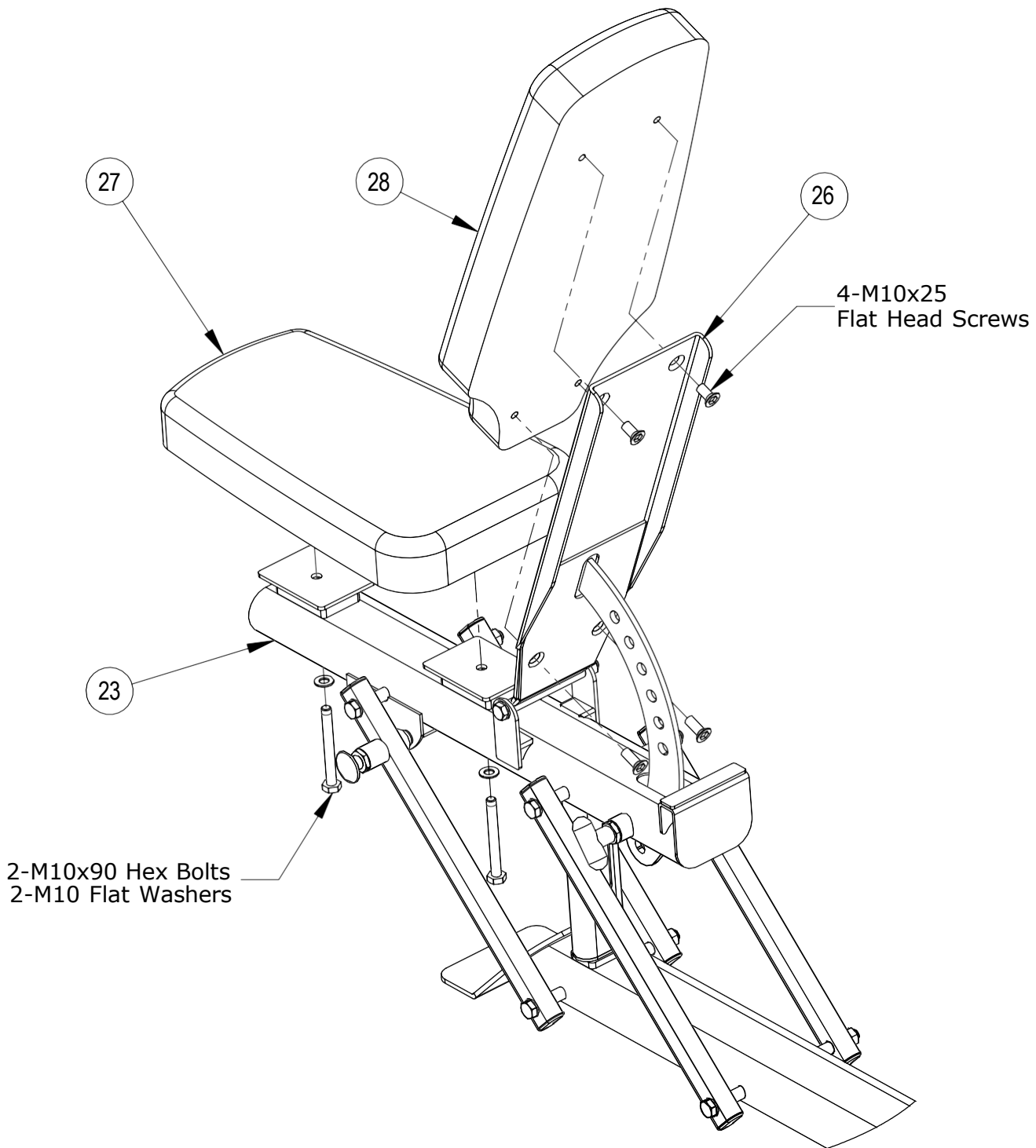

Step 14

- A Attach the Seat Pad (27) to the Seat Frame (23) using 2- M10x90 Hex bolts (52) and 2- M10 Washers (62).
- B Attach the Back Pad (28) to the Back Pad Mount (26) using 4- M10x25 Flat Head Bolts (56).

Tighten hardware now.

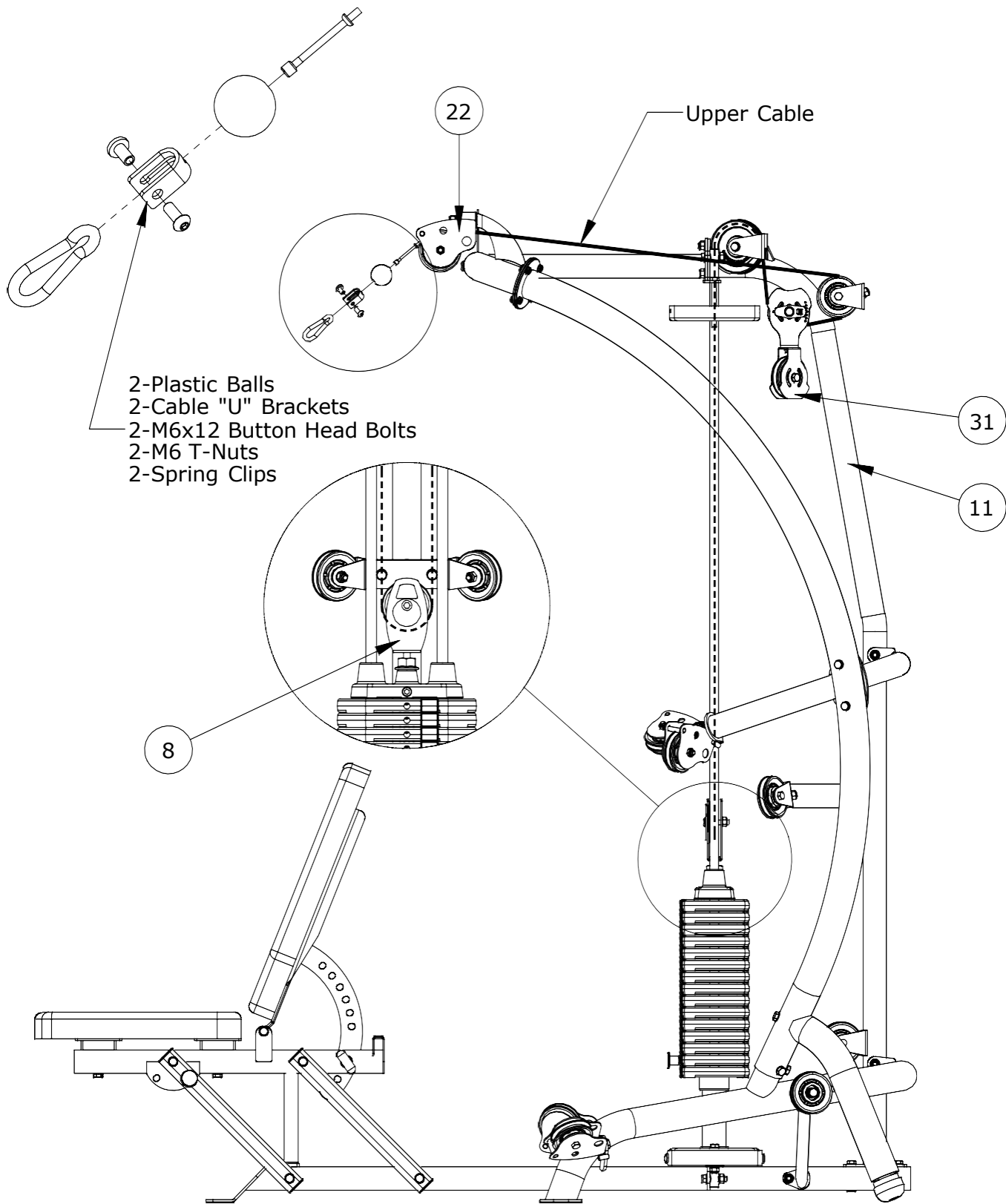

Step 15

- A Route the Upper Cable starting from the top Swivel Pulley (22). Follow the picture shown above.
- B After the cable is routed through the Adjustable Pulley (8), it should be routed exactly the same as the picture but on the opposite side of the machine.

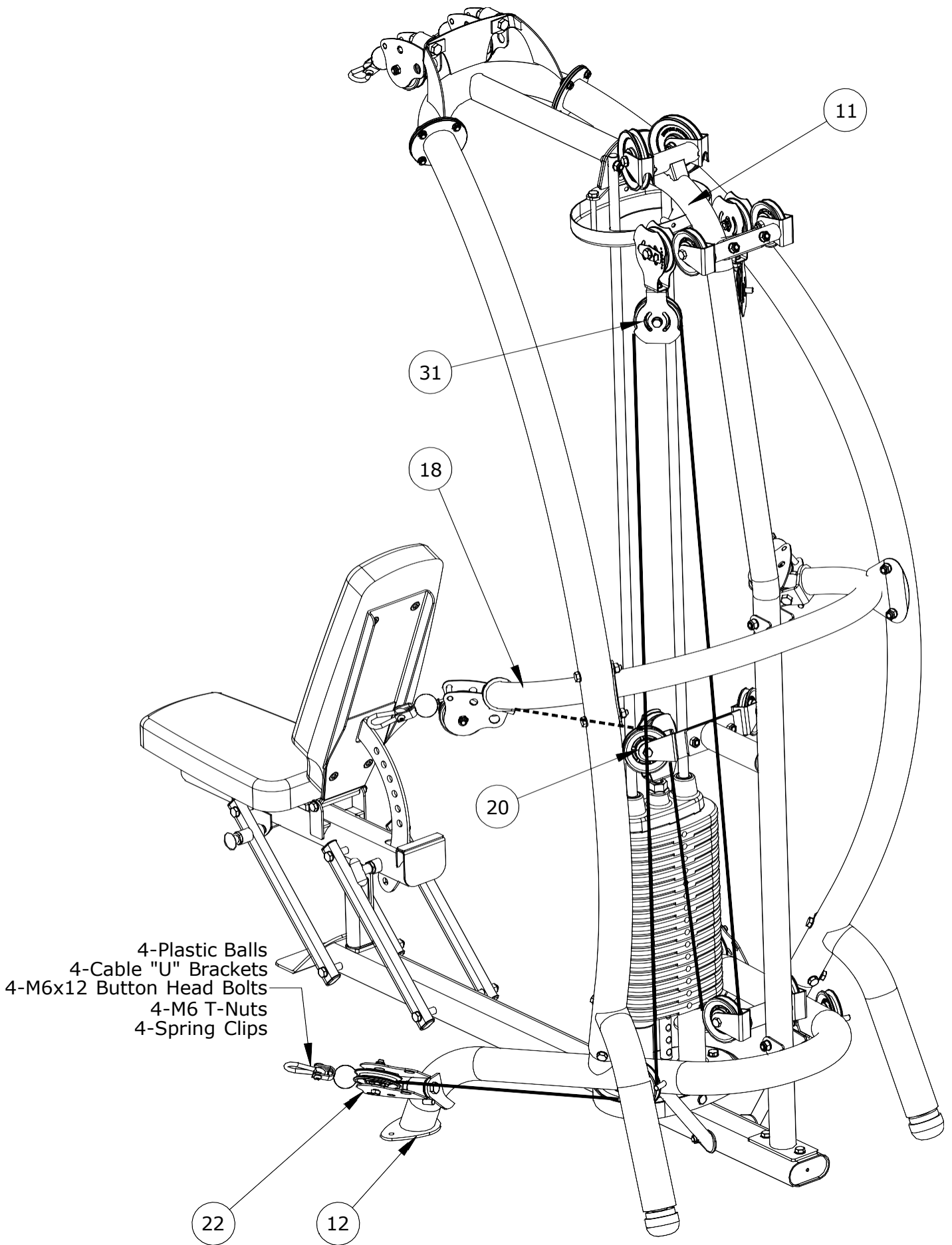

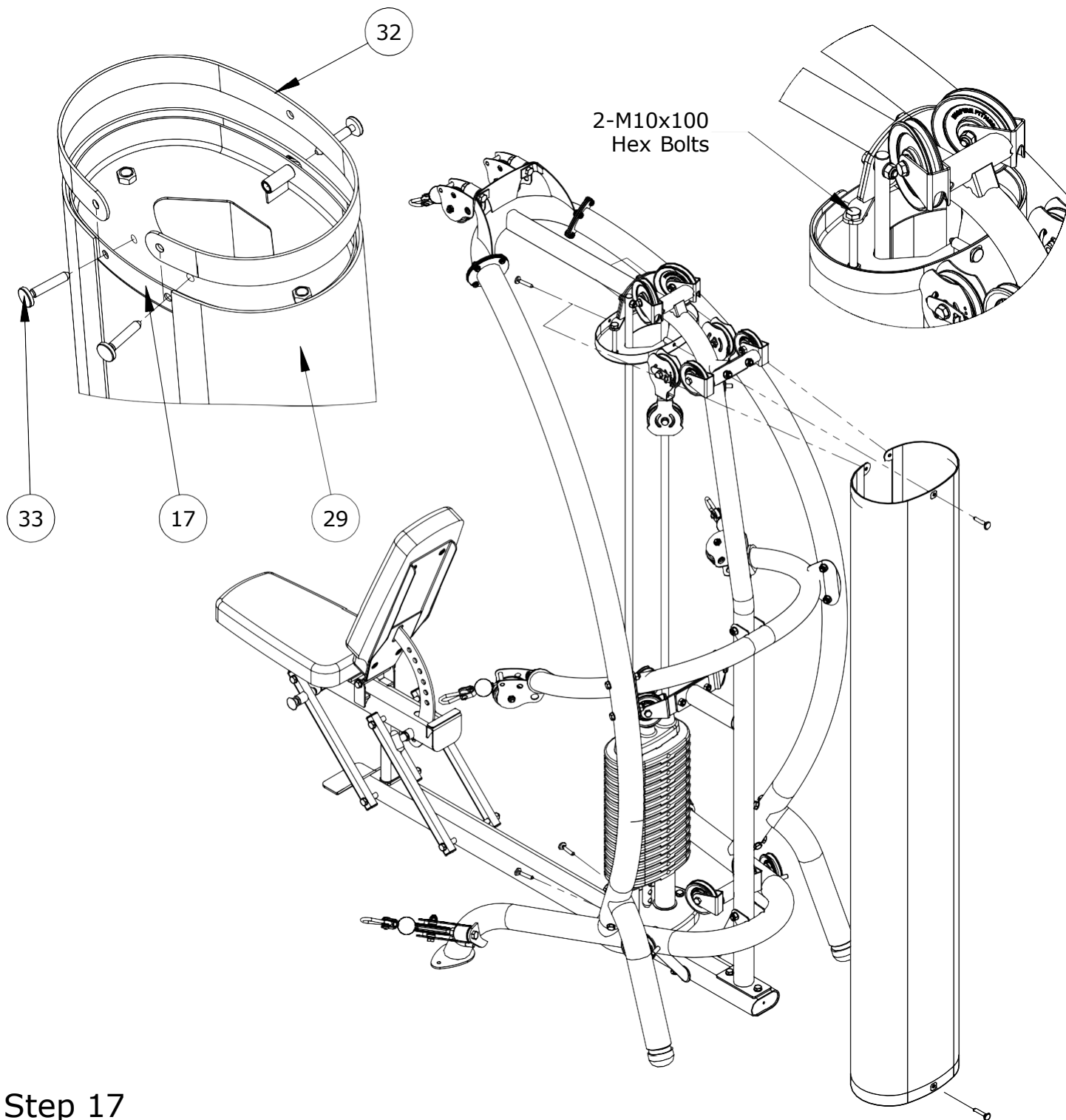

Step 17

- A** Slide the C shaped Shroud Bracket into the pocket at one end of Shroud. (**Pocket seam should face the inside**). Work the shroud around the bracket until the opening in the back of the shroud lines up with the hole on the back of the bracket. Repeat this on the opposite end of the shroud.
- B** Now position the shroud assembly around the upper and lower Shroud Mount Plates by working around the guide rods and stack. Align the holes at the top and bottom brackets with the holes in the plates and insert T-Pins (33) in each hole (3 on top and 3 on bottom).
- C** Secure the Top Shroud Plate (17) using the 2-M10x100 Shroud Tensioning Bolts on the Top Beam Assembly (16). Stretch the shroud tight by threading the bolts at the top. Work between the 2 bolts to adjust each side evenly.

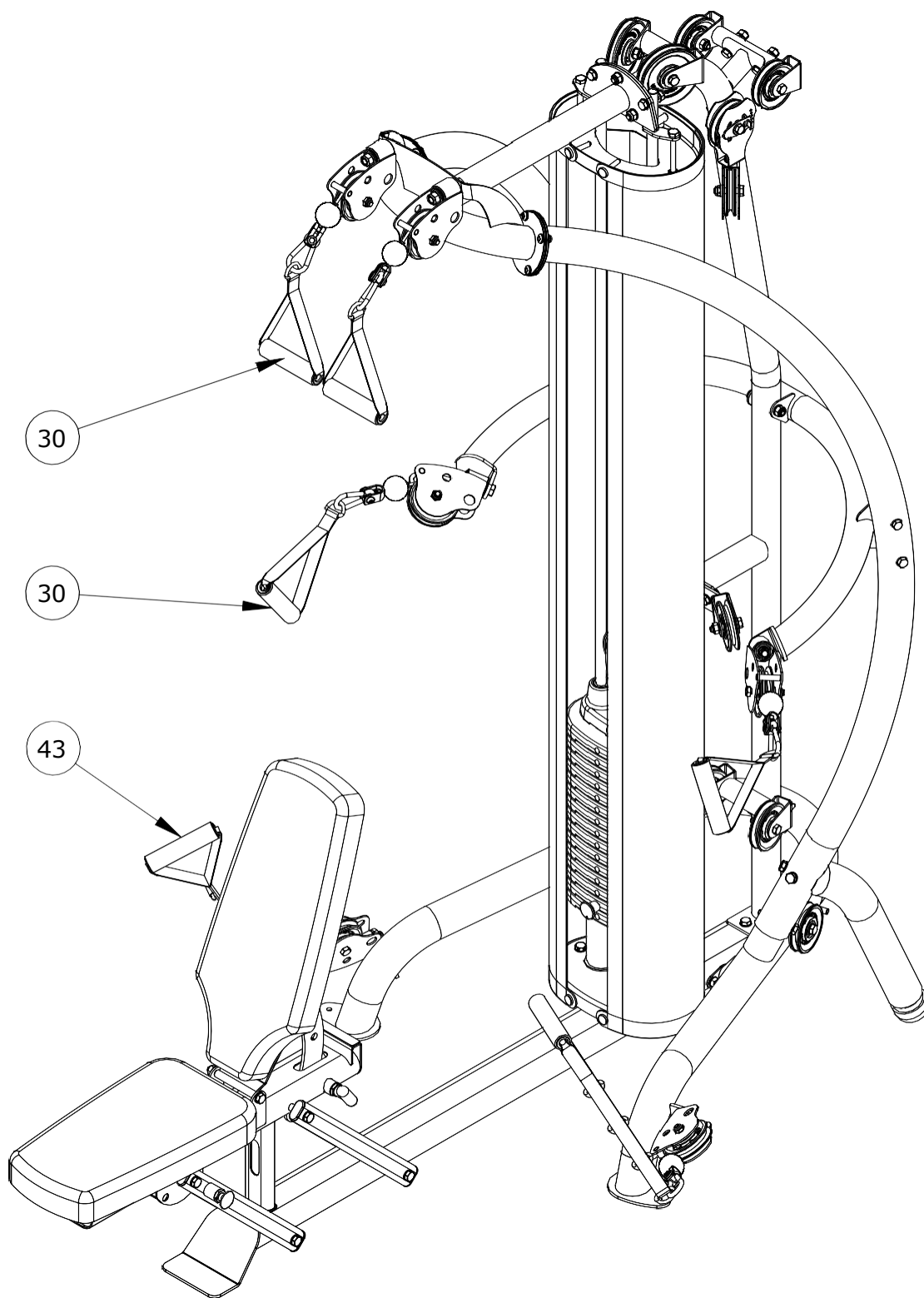

Step 18

A Attach the D-Handle Straps (30, 43) to the cable ends with Spring Clips (67).

DECAL REFERENCE

NOTICE				
<i>This INSPIRE product is not intended for commercial use.</i>				
<i>IN HOME MAINTENANCE</i>	<i>Weekly</i>	<i>3 Months</i>	<i>Yearly</i>	<i>2 Years</i>
Inspect; Links, Pull Pins, Snap Locks, Swivels, Weight Stack Pins	✗			
Clean; Upholstery	✗			
Inspect; Cables and their fittings	✗			
Inspect tightness of all shrouds	✗			
Inspect; Accessory Bars and Handles		✗		
Inspect; All Decals		✗		
Inspect; All nuts and Bolts Tighten if Needed.		✗		
Inspect; Anti-Skid Surfaces		✗		
Clean & Lubricate; Guide Rods with a Teflon(PTFE) based lubricant (Superlube)		✗		
Lubricate; Seat Sleeves and all plastic slides		✗		
Clean & Wax; All Glossy Finishes			✗	
Replace; Cables, Belts and Connectin Parts.				✗



This product is covered by one or more of the following U.S. Patents: 7,722,513; 7,837,600; 7,905,818; 5,330,405; 5,944,641; 5,961,427; and others pending



DECAL REFERENCE

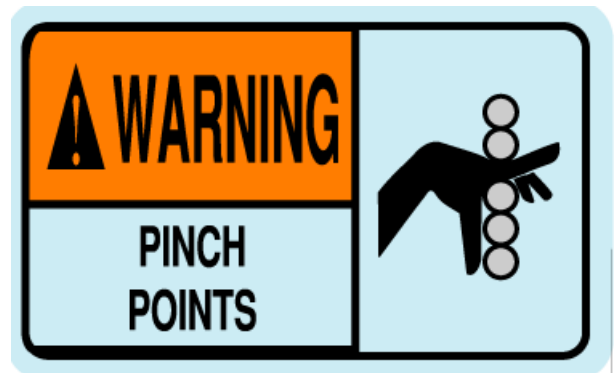
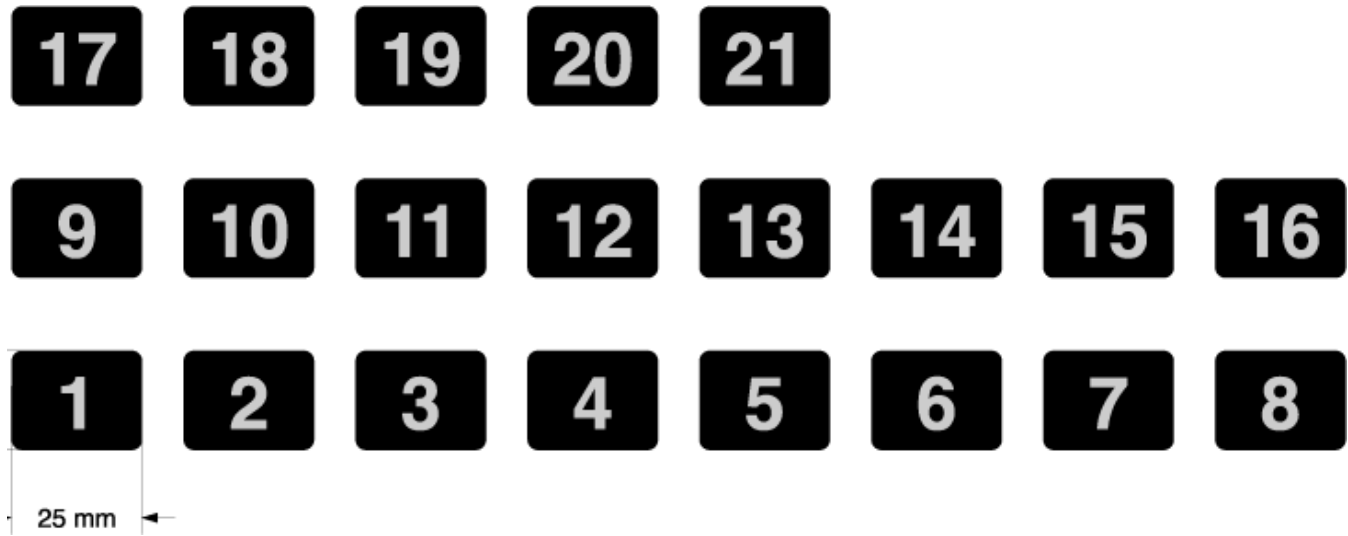

DECAL PLACEMENT

"Inspire M1"
below logo
label (45 x 33)

"DANGER, THIS PRODUCT
NOT DESIGNED FOR
COMMERCIAL USE" on
base in front (80 x 40)

"WARNING"
Label on side
of upright.
(40 x 170)

"NOTICE"
Label on side
of upright,
under
warning label.
(40 x 170)

Weight # labels
(1 - 21),
included with
manual. Silver
#'s on black
background. (18
x 25)

Serial # label
(40 x 30)

"WARNING, PINCH
POINTS" on top of
seat frame & in front
of weights. (40 x 25)

"Patent" Label
placed just above
the "Notice" label
(50 x 30)

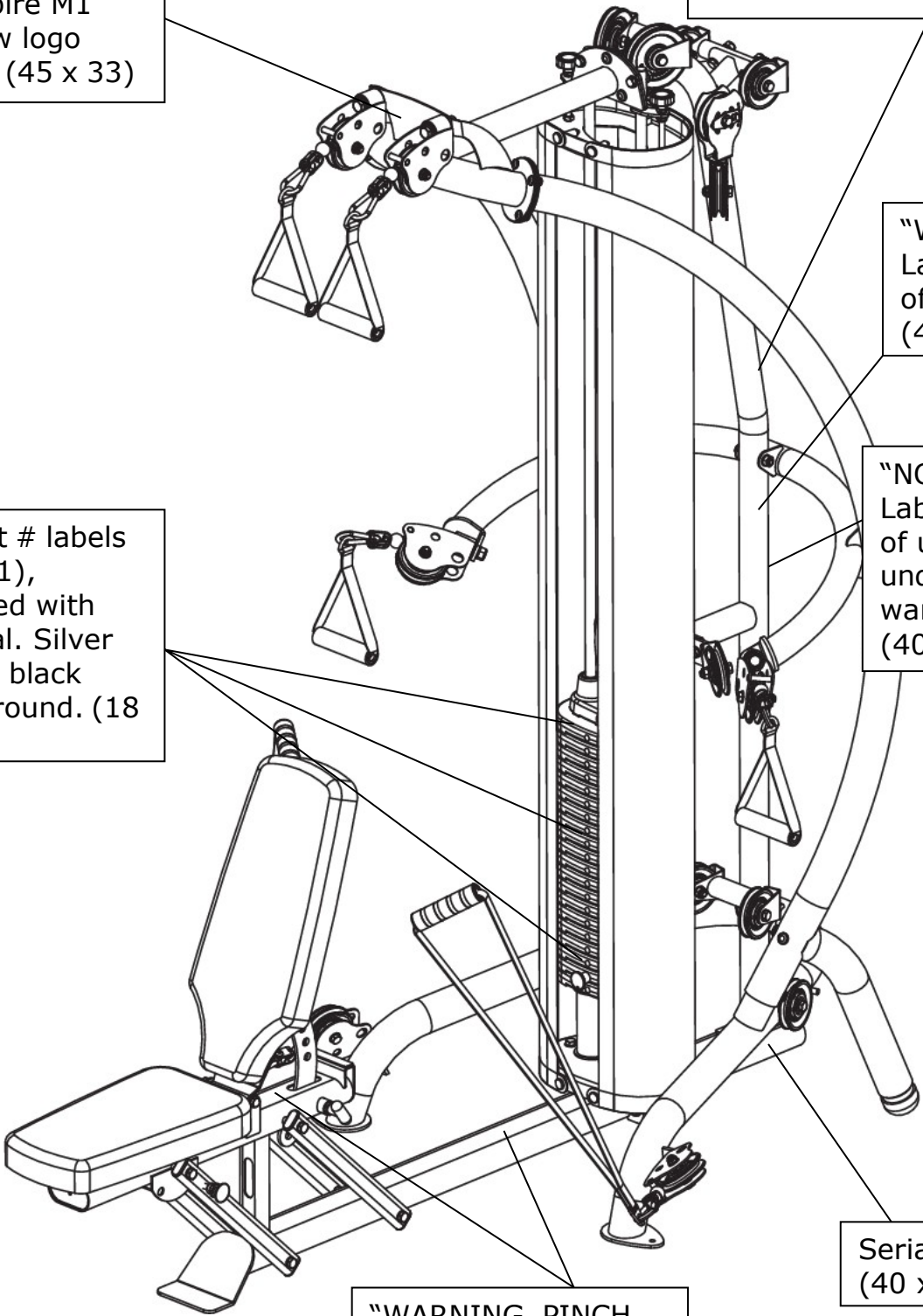

HOME GYM OPTIONS (Sold Separately)

- Heavy Stack (50lbs)
- Revolving Lat Bar
- Revolving EZ Curl Bar
- Ankle Strap

Training Tips

CONSULT A PHYSICIAN BEFORE STARTING ANY EXERCISE PROGRAM

1. **Always warm up** before you start weight training. This helps get your muscles warm and prevents injury. You can warm up with light cardio or by doing a light set of each exercise before going to heavier weights.
2. **Control the weight.** Always work with a weight that you can handle through a full range of motion. Slow and steady movements are recommended.
3. **Breathe.** Don't hold your breath during your set. Holding your breath builds internal pressure which increases your chance for broken blood vessels, as well as a hernia.
4. **Sit up straight.** Pay attention to your posture and keep everything straight. Engage your abs in every movement to keep balanced and protect your spine.

GENERAL MAINTENANCE INFORMATION

Warning: DO NOT place styrofoam or printed materials on the orthopedic seat pads. Over time, these may stick to the pads and mar the surface.

Do not leave items sitting on the orthopedic seat pads, these pads have a special density that takes shape to objects and small objects will leave imprints in the surface that may take time to come out.

- Periodically inspect the cables for splitting, cracking or fraying. Also, watch for bulging or flat areas in the cable.
- Immediately replace cables at the first signs of damage or wear. Never use equipment with damaged or worn cables.
- Cables naturally stretch over time, so check cable slack periodically and adjust cable tension as needed. See Step 55 to adjust cable tension.
- Regularly inspect product for loose hardware.
- Do not use or store equipment outdoors.
- Inspect snap links, swivels, handles and weight stack pin for wear or damage. If wear or damage exists, replace immediately.
- Locate and familiarize yourself with all warning decals on the home gym.
- Replace damaged or worn upholstery immediately.
- Periodically wipe down guide rods with a dry cloth and re-apply a thin coat of a teflon-based lubricant.

MAINTENANCE SCHEDULE

ROUTINE	HOME MAINTENANCE	ENTRY DATE												
Inspect: Links, Pull Pins, Spring Clips, Swivels, Weight Stack Pins	WEEKLY													
Clean: Upholstery	WEEKLY													
Inspect: Cables and their Fittings	WEEKLY													
Inspect: Tautness of all Shrouds	WEEKLY													
Inspect: Accessory Bars and Handles	3 MONTHS													
Inspect: All Decals	3 MONTHS													
Inspect: All Nuts and Bolts. Tighten if Needed	3 MONTHS													
Inspect: Anti-Skid surfaces	3 MONTHS													
Clean and Lubricate: Guide Rods with a Teflon based lubricant	3 MONTHS													
Lubricate: Seat Sleeves and all Plastic Slides	3 MONTHS													
Clean and Wax: All Glossy Finishes	YEARLY													
Replace: Cables, Belts and Connecting Parts	2 YEARS													

LIMITED WARRANTY

INSPIRE

In-Home Lifetime Warranty.

This Warranty applies only in the United States to Inspire Strength products manufactured or distributed by Health In Motion LLC. The warranty period to the original purchaser is lifetime of the original purchaser.

Health In Motion warrants that the Product you have purchased for non-commercial, personal, family or household use from Health In Motion LLC or from an authorized Health In Motion reseller is free from defects in materials or workmanship under normal use during the warranty period. Your sales receipt, showing the date of purchase of the Product, is your proof of the date of purchase. This warranty extends only to you, the original purchaser. It is not transferable to anyone who subsequently purchases the Product from you. It excludes expendable parts such as paint and finish. This Warranty becomes VALID ONLY if the Product is assembled / installed according to the instructions / directions included with the Product.

Replacement and repair of parts.

During the warranty period Health In Motion will at no additional charge, repair or replace the Product if it becomes defective, malfunctions, or otherwise fails to conform with this Warranty under normal non-commercial, personal, family, or household use. In repairing the product Health In Motion may replace defective parts with, at the option of Health In Motion, serviceable used parts that are equivalent to new parts in performance, or new parts. All exchanged parts and Products replaced under this warranty will become the property of Health In Motion. Health In Motion reserves the right to change manufacturers and or specification of any part to cover any existing warranty.

Service procedures.

To obtain warranty parts, you must return the parts to Health In Motion or an authorized Health In Motion retailer in its original container (or equivalent). You must pre-pay any shipping charges, taxes, or any other charges associated with transportation of the Product. In addition, you are responsible for insuring any Product shipped or returned. You assume the risk of loss during shipment. You must present Health In Motion with proof-of-purchase documents (including the date of purchase, Model, and Serial Number). Any evidence of alteration, erasing or forgery of proof-of-purchase documents will be cause to void this Warranty.

Conditions and Exceptions.

This Warranty does not extend to any Product not purchased from Health In Motion LLC or from an authorized Health In Motion reseller. This Warranty does not extend to any Product that has been damaged or rendered defective; (a) as a result of accident, misuse, or abuse; (b) by the use of parts not manufactured or sold by Health In Motion; (c) by modification of the Product; (d) as a result of service by anyone other than Health In Motion, or an authorized Health In Motion warranty service provider; (e) product that has not been properly maintained (follow maintenance schedule found on product). Should any product submitted for Warranty service be found to be ineligible, an estimate of repair cost will be furnished and the repair will be made if requested by you upon Health In Motion receipt of payment or acceptable arrangement of payment.

Disclaimer

EXCEPT AS EXPRESSLY SET FORTH IN THIS WARRANTY HEALTH IN MOTION MAKES NO OTHER WARRANTIES; EXPRESSED OR IMPLIED INCLUDING ANY IMPLIED WARRANTIES OF MERCHANTABILITY AND FITNESS FOR A PARTICULAR PURPOSE. HEALTH IN MOTION EXPRESSLY DISCLAIMS ALL WARRANTIES NOT STATED IN THIS WARRANTY. ANY IMPLIED WARRANTIES THAT MAY BE IMPOSED BY LAW ARE LIMITED TO THE TERMS OF THIS WARRANTY. NEITHER HEALTH IN MOTION NOR ANY OF ITS AFFILIATES SHALL BE RESPONSIBLE FOR INCIDENTAL OR CONSEQUENTIAL DAMAGES. HEALTH IN MOTION IS NOT RESPONSIBLE FOR THE REPAIR OR REPLACEMENT OF ANY PARTS THAT HEALTH IN MOTION DETERMINES HAVE BEEN SUBJECTED AFTER THE DATE OF MANUFACTURE TO ALTERATION, NEGLIGENCE, ABUSE, MISUSE, NORMAL WEAR & TEAR, ACCIDENT, DAMAGE DURING TRANSIT OR INSTALLATION, FIRE, FLOOD, OR ANY ACT OF GOD. SOME STATES DO NOT ALLOW LIMITATIONS ON HOW LONG AN IMPLIED WARRANTY LASTS OR THE EXCLUSION OR LIMITATION OF INCIDENTAL OR CONSEQUENTIAL DAMAGES, SO THE ABOVE LIMITATIONS OR EXCLUSION MAY NOT APPLY TO YOU. This Warranty gives you specific legal rights and you may also have other rights that may vary from state to state. This is the only express warranty applicable to Health In Motion's "Inspire" branded strength products. Health In Motion neither assumes nor authorizes anyone to assume for it any other express warranty.