

INSPIRE

ASSEMBLY & OPERATION MANUAL

LEGIPRESS 3 OPTION

For 2014 M2 & M3, and M5

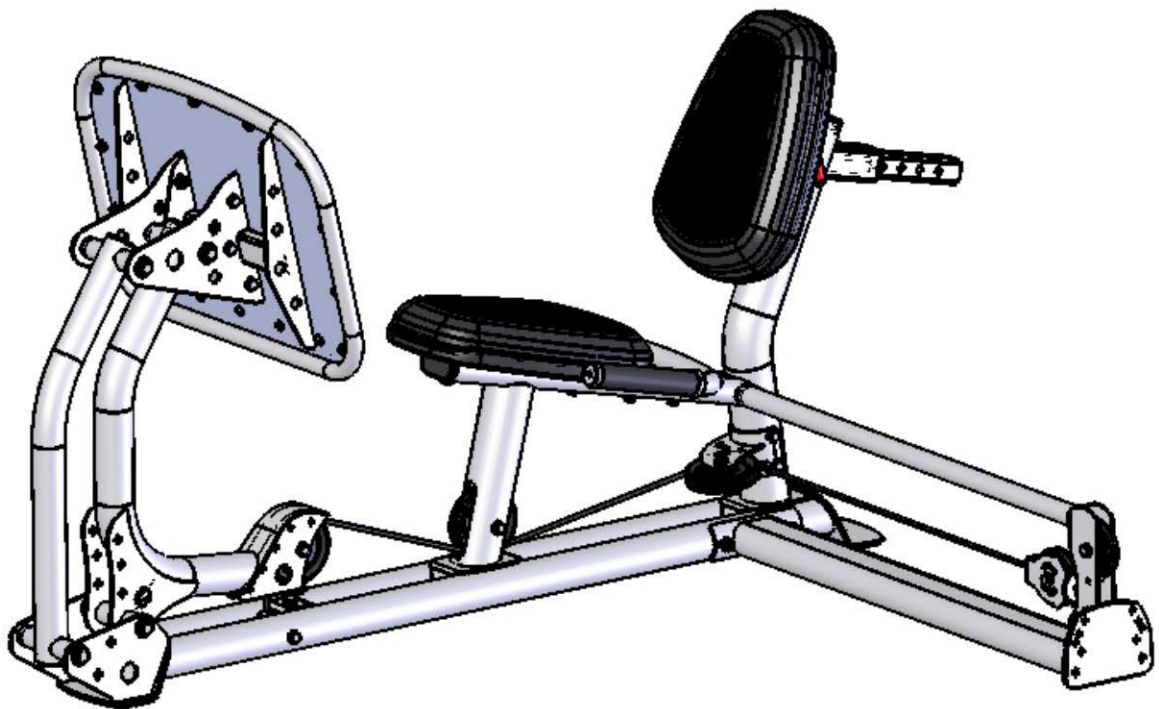

RECORD SERIAL NUMBER HERE

CONGRATULATIONS... You've just taken the first step to a healthier and stronger body. This leg press by Inspire offers the key to unlocking your body's potential. Regular strength training on a multi-gym has been shown to deliver a host of benefits including: increased muscle tone, decreased body fat, improved energy levels, a reduction in stress, and improved cardiac output. Once again, congratulations, you are on your way to improving your self image, overall health, and quality of life.

BEFORE ASSEMBLING YOUR LEG PRESS

IMPORTANT: Read this entire manual before attempting to build or use this leg press. This manual contains step by step instructions for proper assembly.

Use the parts list included in this manual to verify that all parts are accounted for before assembly. If any parts are missing, contact the retailer of this leg press for replacement parts or call Inspire at 877-738-1729.

Make sure that adequate room has been cleared before attempting to build your leg press. A rubber mat is recommended for use under your leg press to protect wood flooring or carpeting from damage during assembly and usage.

This leg press is intended for indoor use only. Rust can form on certain parts in a humid environment resulting in impaired function.

Service of your leg press should only be preformed by an authorized Inspire retailer. Service preformed by anyone else can result in loss of warranty. If you need help finding an authorized retailer, please contact us directly:

Inspire Fitness
4945 East Hunter Avenue
Anaheim, CA 92807
Ph: 877-738-1729
Fx: 714-738-1728
www.inspirefitness.net

TABLE OF CONTENTS

Section Description	Page
Safety Instructions.....	1
Tools Required.....	1
Parts & Hardware List.....	2
Cable Chart	3
Exploded Diagram.....	4
Assembly Instructions – attaching to M2	5-6
Assembly Instructions – attaching to M3.....	7-9
Leg Press General Instructions for M2 and M3.....	10-14
Assembly Instructions – attaching to M5.....	15-16
Leg Press General Instructions for M5.....	17-21
Decal Reference.....	22
Decal Placement.....	23
General Maintenance Information.....	24
Maintenance Schedule.....	25
Limited Warranty.....	26

IMPORTANT SAFETY INSTRUCTIONS

Please read this entire manual and familiarize yourself with all decals and warnings before using this leg press.

- **WARNING!** It is necessary to inspect this leg press regularly to maintain safety and proper function. Please use the maintenance schedule included towards the back of this manual. Immediately replace any and all defective or worn parts. Pay special attention to moving parts such as the cables and pulleys and connections to accessories. See General Maintenance section for complete details.
- Use this leg press for its intended purpose as described in this Operation Manual or the Exercise Book. Do not use attachments not recommended by the manufacturer.
- Make sure bystanders are at least 5 feet away from the leg press while it is in use.
- Keep children off the leg press at all times.
- Keep the leg press away from walls and clear of any obstructions and furniture.
- Stop immediately if you experience shortness of breath, pain, or dizziness during your workout. Inspire strongly recommends consulting your doctor before starting an exercise program.

TOOLS REQUIRED FOR ASSEMBLY

- Metric socket set (including 16mm, 17mm, 18mm, and 19mm sockets)
- Metric 16mm, 17mm, 18mm, and 19mm wrenches
- 6mm, 5mm, and 4mm Allen wrenches (supplied in hardware pack)
- Adjustable wrench

Parts and Hardware List

Item	Description	Part Number	QTY	Rec'd
1	Base Frame	GM872-260-000	1	
2	Attachment Arm	GM872-380-000	1	
3	Press Arm	GM872-240-000	1	
4	Stablizer Arm	GM872-220-000	1	
5	Foot Plate	GM872-340-000	1	
6	Wood Seat Base	GM870-400-002	2	
7	Seat Handle	GM872-320-000	1	
8	Floating Pulley Bracket	GM870-380-001	1	
9	Back Pad Stem	GM872-380-005PZ	1	
10	Pulley, 3 1/2"	GM692-880-001	1	
11	Pulley Mount	GM872-380-006PZ	1	
12	Foot Plate Connector Plate	GM872-381-025	2	
13	LP3 Main Cable	GM872-500-005	1	
14	LP3-M5 Adapter Plate	GM872-381-019	1	
15	LP3-M5 Cable	GM872-500-006	1	

Item	Hardware Description	QTY	Rec'd
1	Hex Bolt, M10 x 25	9	
2	Hex Bolt, M10 x 45	3	
3	Hex Bolt, M10 x 60	4	
4	Hex Bolt, M10 x 90	1	
5	Hex Bolt, M10 x 95	3	
6	Hex Bolt, M10 x 100	2	
7	Hex Bolt, M10 x 110	1	
8	Hex Bolt, M10 x 125	1	
9	Hex Bolt, M10 x 160	1	
10	Hex Bolt, M10 x 165	2	
11	Hex Bolt, 1/2" x 165	4	

12	M10 Flat Washer	41	
13	1/2" Flat Washer	8	

14	M10 Locknut	18	
15	1/2-13 Locknut	4	

16	Cable Adapter	1	
17	Barrel Spacer, 3/8" Long	1	
18	Barrel Spacer, 1 5/16" Long	1	
19	Cable End (GM870-561-019)	1	
20	Sleeve Bushing (GM870-561-023)	1	

Note: Depending on which machine the LP3 is attached to, there may be extra hardware left over.

CABLE CHART



LP3 MAIN CABLE
GM872-500-005



LP3-M5 LEG PRESS CABLE
GM872-500-006

Exploded Diagram

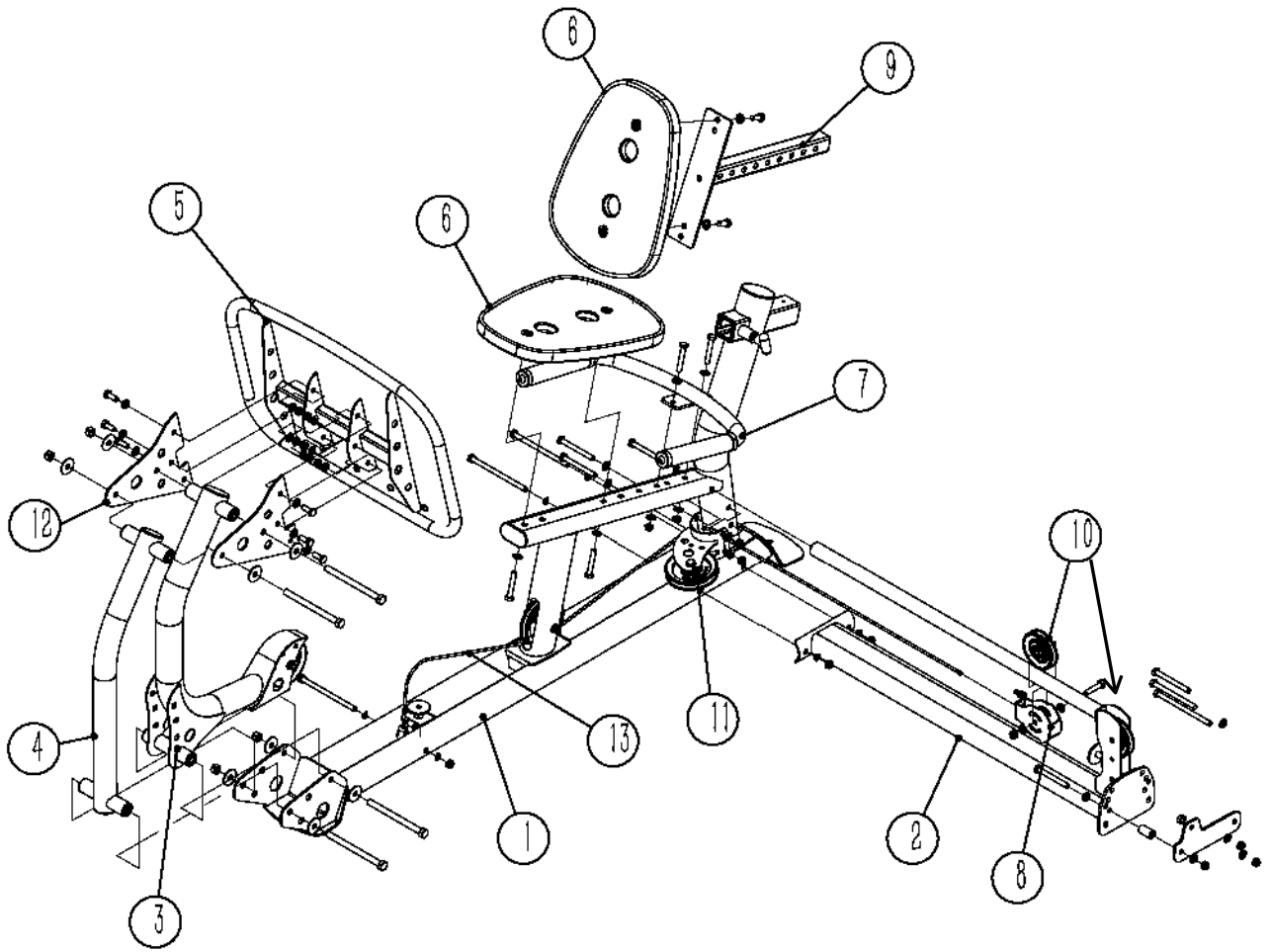

Assembly Procedure for Attaching the LP3 to an M2

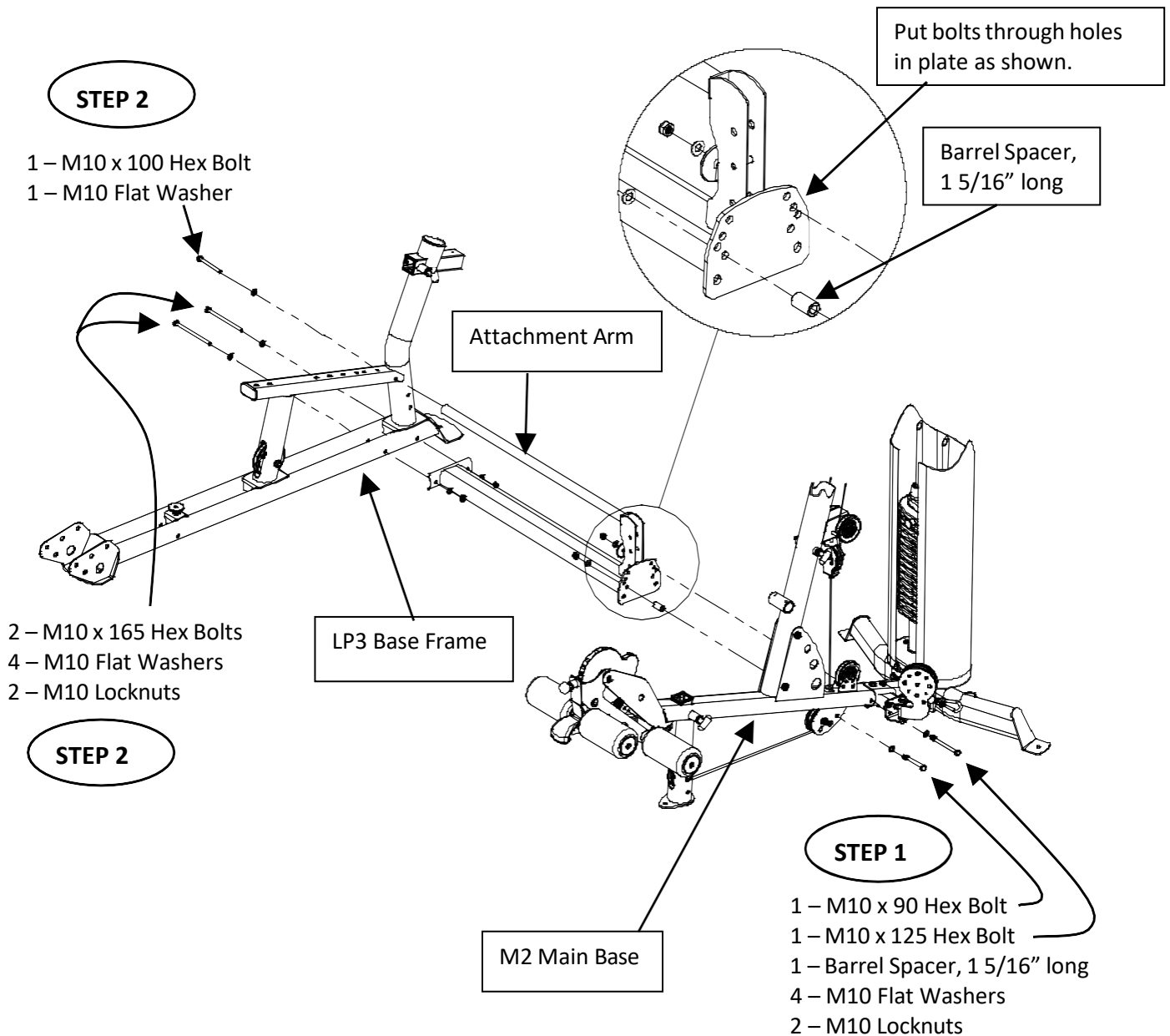

Step 1: Attach Attachment Arm to the M2 Main Base using:

Finger Tighten Only

- 1 - M10 x 90 Hex Bolt
- 1 - M10 x 125 Hex Bolt
- 1 - Barrel Spacer, 1 5/16" long
- 4 - M10 Flat Washers
- 2 - M10 Lock Nuts

Step 2: Attach Attachment Arm to the LP3 Base Frame using:

Tighten the hardware in Steps 1 and 2.

- 1 - M10 x 100 Hex Bolt
- 2 - M10 x 165 Hex Bolts
- 5 - M10 Washers
- 2 - M10 Locknuts

Assembly Procedure for Attaching the LP3 to an M2

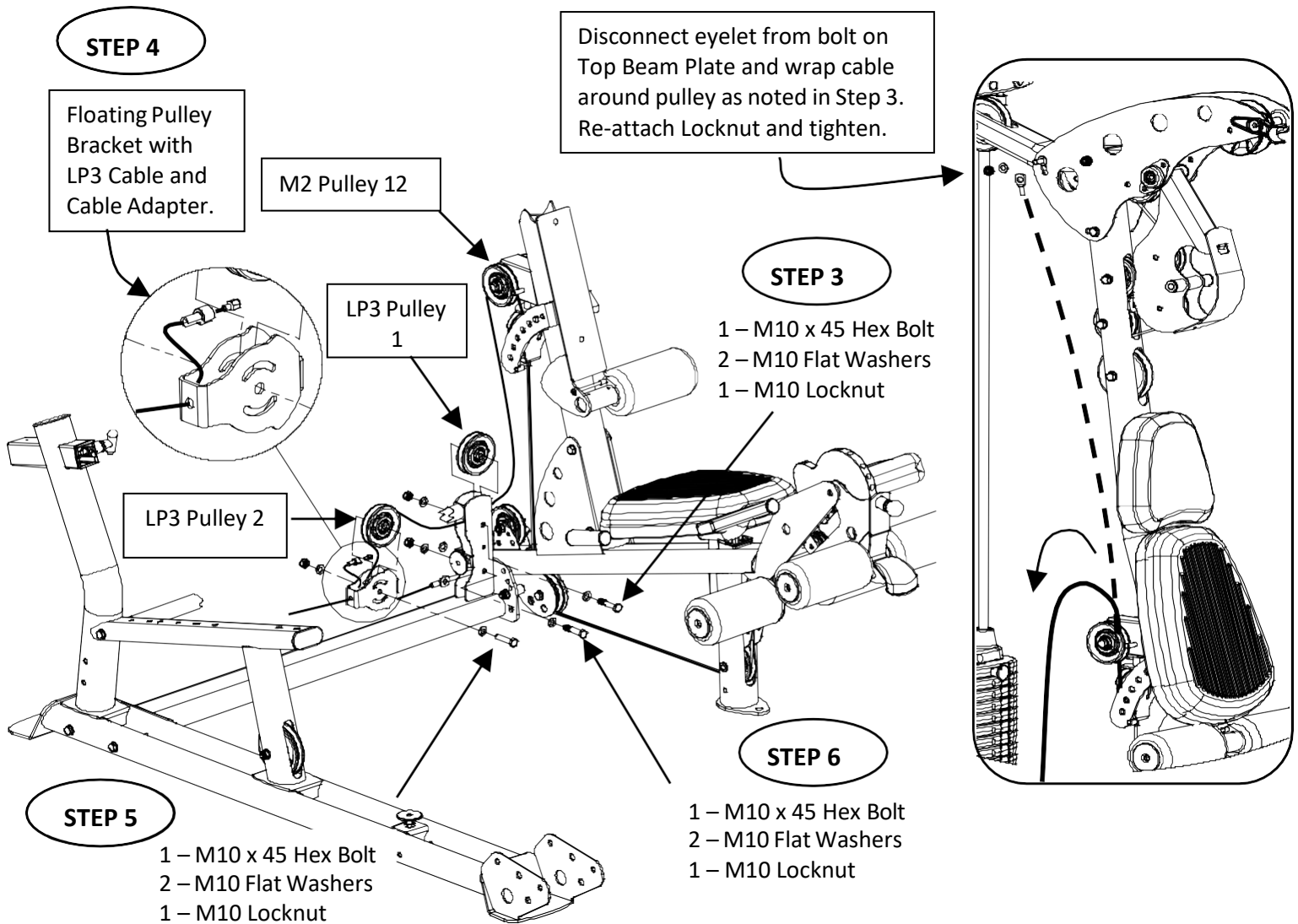

Step 3: Route the Middle Cable over the top of and down from the M2 Pulley 12 and towards the Attachment Arm frame as shown. Thread the Middle Cable through the plates in the Attachment Arm as you place the LP3 Pulley 1 on top of it and bolt the pulley in place using:

- 1 - M10 x 45 Hex Bolt**
- 2 - M10 Flat Washers**
- 1 - M10 Lock Nut**

Step 4: Attach LP3 Cable end to the Floating Pulley Bracket with the Cable Adapter as show in the circle.

Step 5: Attach LP3 Pulley 2 to the Floating Pulley Bracket while routing the Middle Cable as shown using:

- 1 - M10 x 45 Hex Bolt**
- 2 - M10 Flat Washers**
- 1 - M10 Lock Nut**

Step 6: Fasten the eyelet end of the Middle Cable between the plates in the Attachment Arm using:

- 1 - M10 x 45 Hex Bolt**
- 2 - M10 Flat Washers**
- 1 - M10 Lock Nut**

Tighten all the hardware in Steps 3, 5 and 6.

GO TO PAGE 10 TO COMPLETE LP3 ASSEMBLY

Assembly Procedure for Attaching the LP3 to an M3

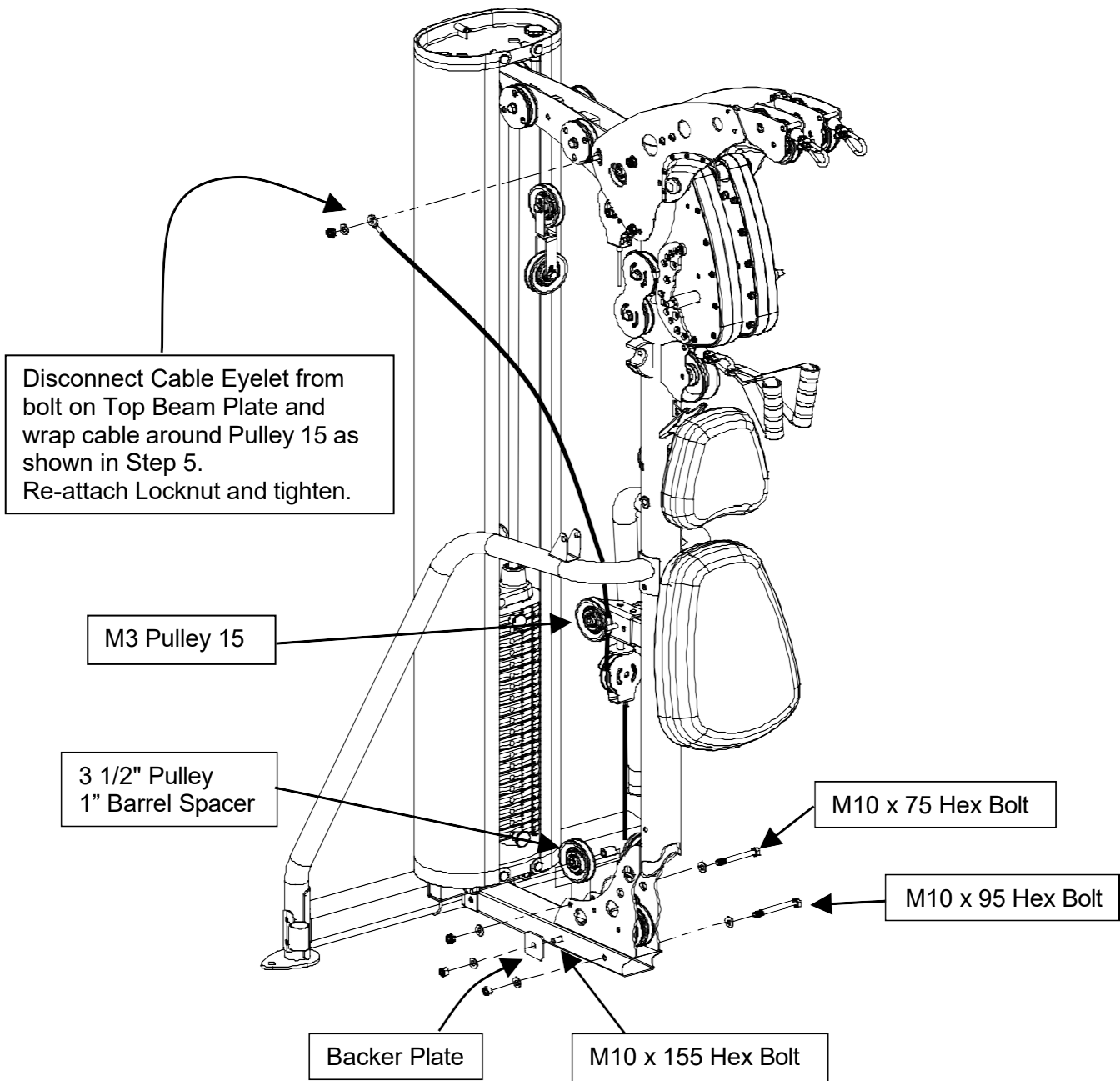

STEP 1: Remove the M10 x 95 Hex Bolt, M10 x 75 Hex Bolt with the 3 1/2" Pulley and 1" long Barrel Spacer. Remove the Backer Plate from the M10 x 155 Hex Bolt, but leave the M10 x 155 Hex Bolt in place. It will be used later.

STEP 2: Disconnect the Cable Eyelet from the Top Beam Plate and wrap around M3 Pulley 15. The Eyelet will be attached to the Attachment Arm later. Re-attach the M10 locknut to the bolt in the Top Beam Plate and tighten.

Assembly Procedure for Attaching the LP3 to an M3

STEP 4

- 1 – M10 x 100 Hex Bolt
- 1 – M10 Flat Washer

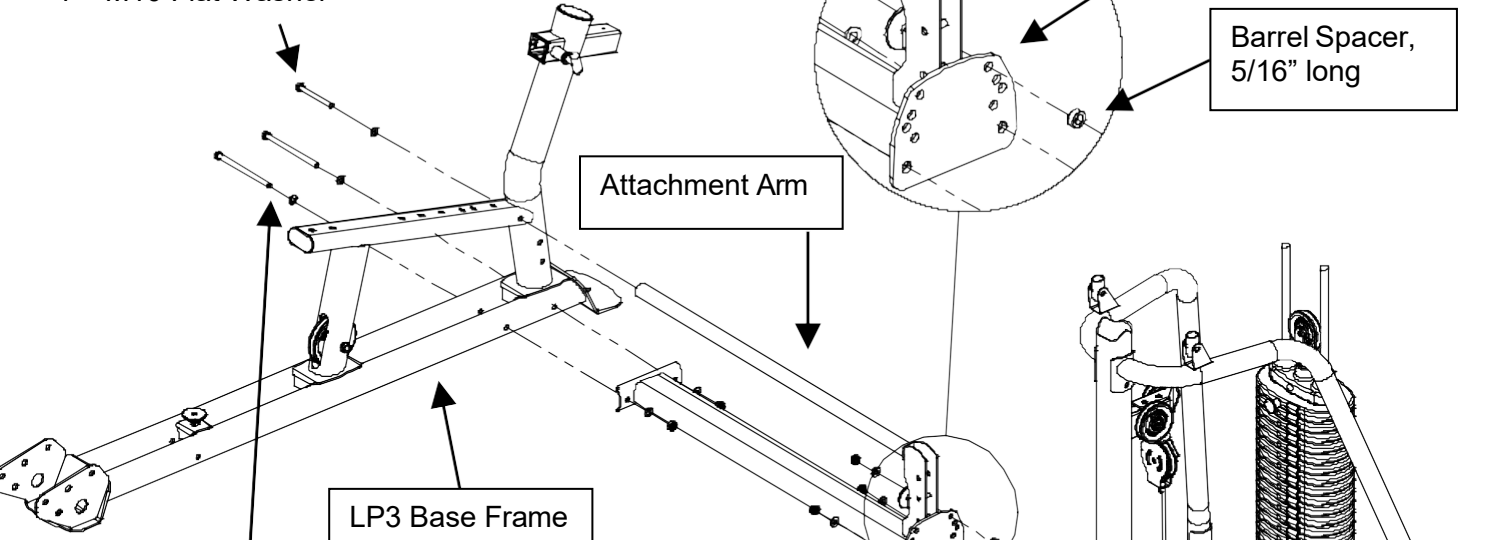

Put bolts through holes as shown

Barrel Spacer, 5/16" long

Attachment Arm

LP3 Base Frame

STEP 4

- 2 – M10 x 165 Hex Bolts
- 4 – M10 Flat Washers
- 2 – M10 Locknuts

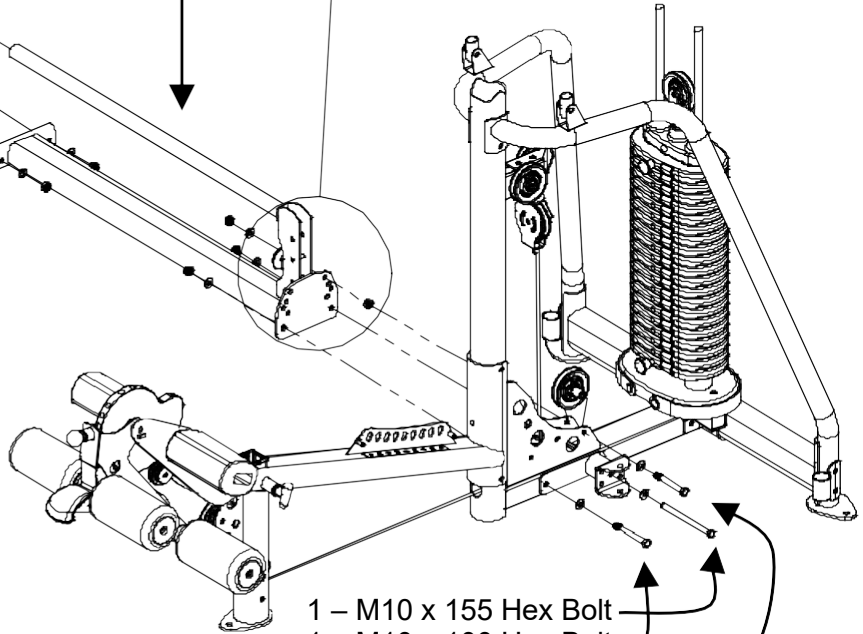

- 1 – M10 x 155 Hex Bolt
- 1 – M10 x 100 Hex Bolt
- 1 – M10 x 90 Hex Bolt
- 1 – Barrel Spacer, 5/16" long
- 6 – M10 Flat Washers
- 3 – M10 Locknuts

STEP 3

The M10 X 155 Hex Bolt is supplied with the M3 gym. It is not part of the LP3 hardware pack.

Step3: Attach the Attachment Arm to the Main Upright using:

- 1 – M10 x 155 Hex Bolt
- 1 – M10 x 100 Hex Bolt
- 1 – M10 x 90 Hex Bolt
- 1 – Barrel Spacer, 5/16" long
- 6 – M10 Flat Washers
- 3 – M10 Locknuts

Step 4: Attach the Attachment Arm to the LP3 Base Frame using:

- 1 – M10 x 100 Hex Bolt
- 2 – M10 x 165 Hex Bolts
- 5 – M10 Flat Washers
- 2 – M10 Locknuts

Tighten the hardware in Steps 3 and 4 now.

Assembly Procedure for Attaching the LP3 to an M3

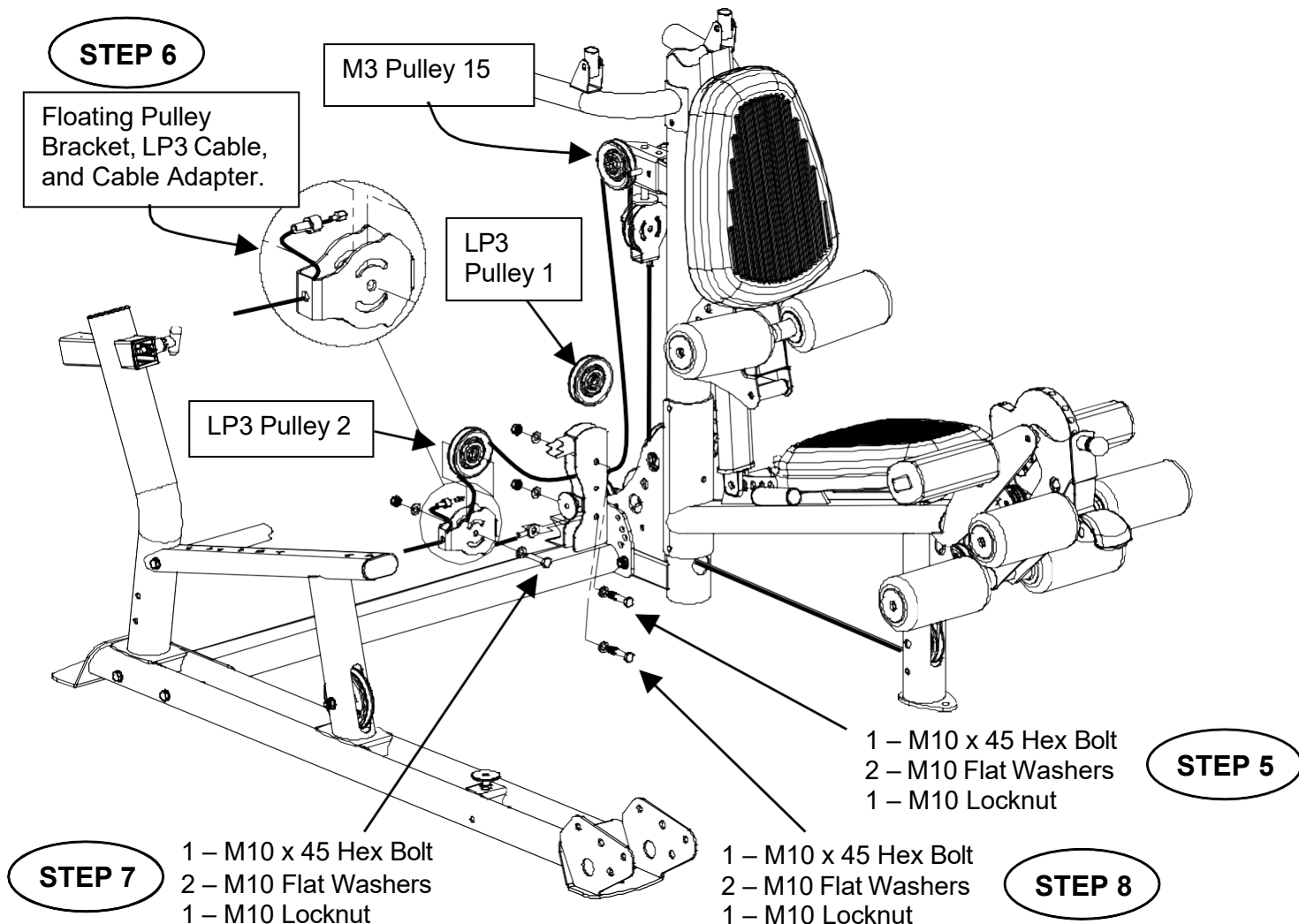

STEP 5: Route the Middle Cable over the top of and down from the M3 Pulley 15 and towards the Attachment Arm Frame as shown. Thread the Middle Cable through the plates on the Attachment Arm as you place the LP3 Pulley 1 on top of it and bolt the pulley in place using:

1 - M10 x 45 Hex Bolt
2 - M10 Flat Washers
1 - M10 Lock Nut

STEP 6: Attach LP3 Cable end to the Floating Pulley Bracket with the Cable Adapter as shown in the circle.

STEP 7: Attach LP3 Pulley 2 to the Floating Pulley Bracket while routing the Middle Cable as shown using:

1 - M10 x 45 Hex Bolt
2 - M10 Flat Washers
1 - M10 Lock Nut

STEP 8: Fasten the eyelet end of the Middle Cable between the plates on the Attachment Arm using:

1 - M10 x 45 Hex Bolt
2 - M10 Flat Washers
1 - M10 Lock Nut

Tighten all the hardware in Steps 5, 7 and 8 at this time.

GO TO PAGE 10 TO COMPLETE LP3 ASSEMBLY

Use these instructions to assemble the Leg Press after it has been attached to your home gym

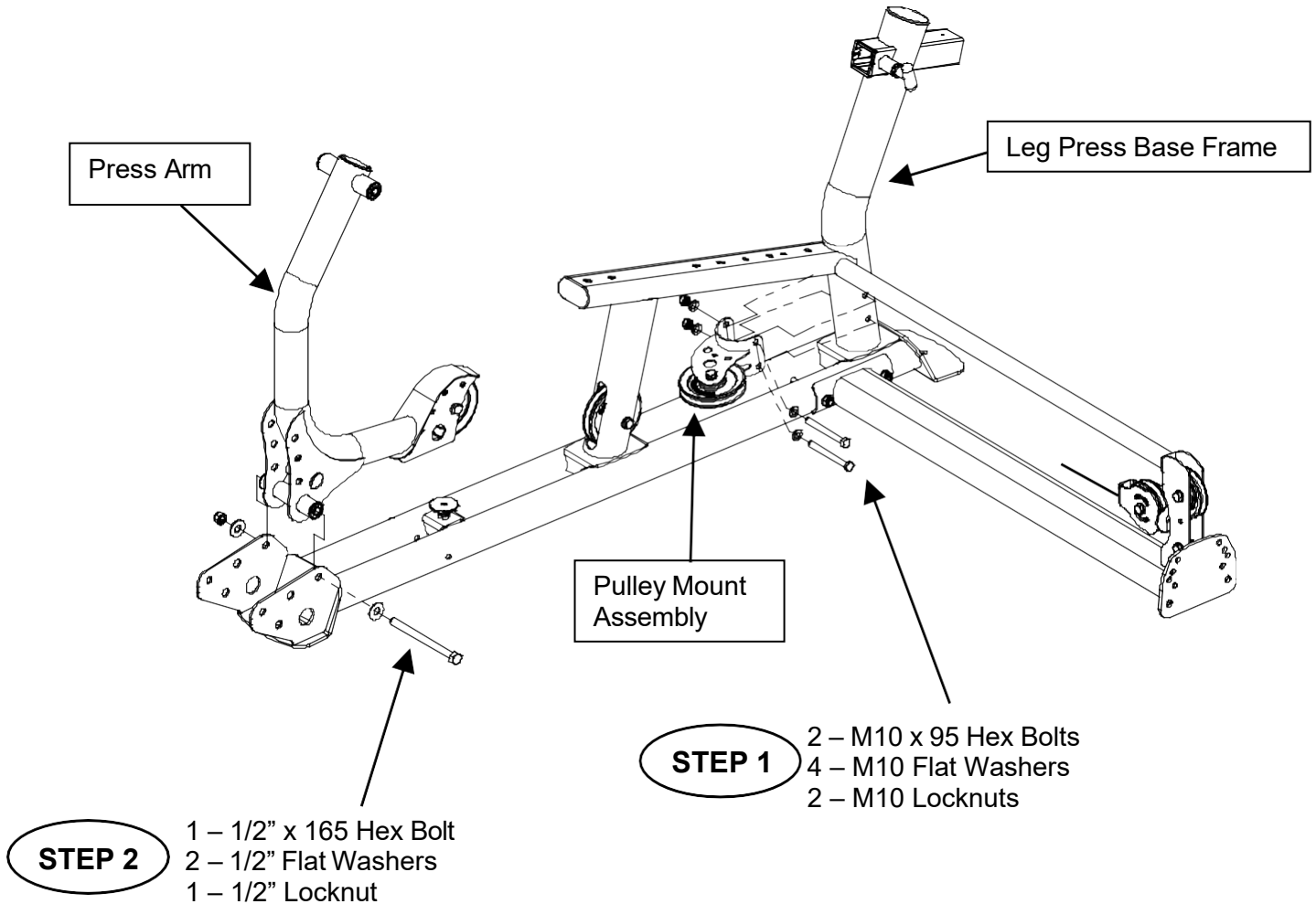

Step 1: Attach the LP3 Pulley Mount to the Base Frame using:

2 – M10 x 95 Hex Bolts
4 – M10 Flat Washers
2 – M10 Locknuts

Step 2: Attach the LP3 Press Arm to the Base Frame using:

1 – 1/2" x 165 Hex Bolt
2 – 1/2" Flat Washers
1 – 1/2" Locknut

Tighten the hardware in Steps 1 and 2. Make sure the Press Arm is able to move easily.

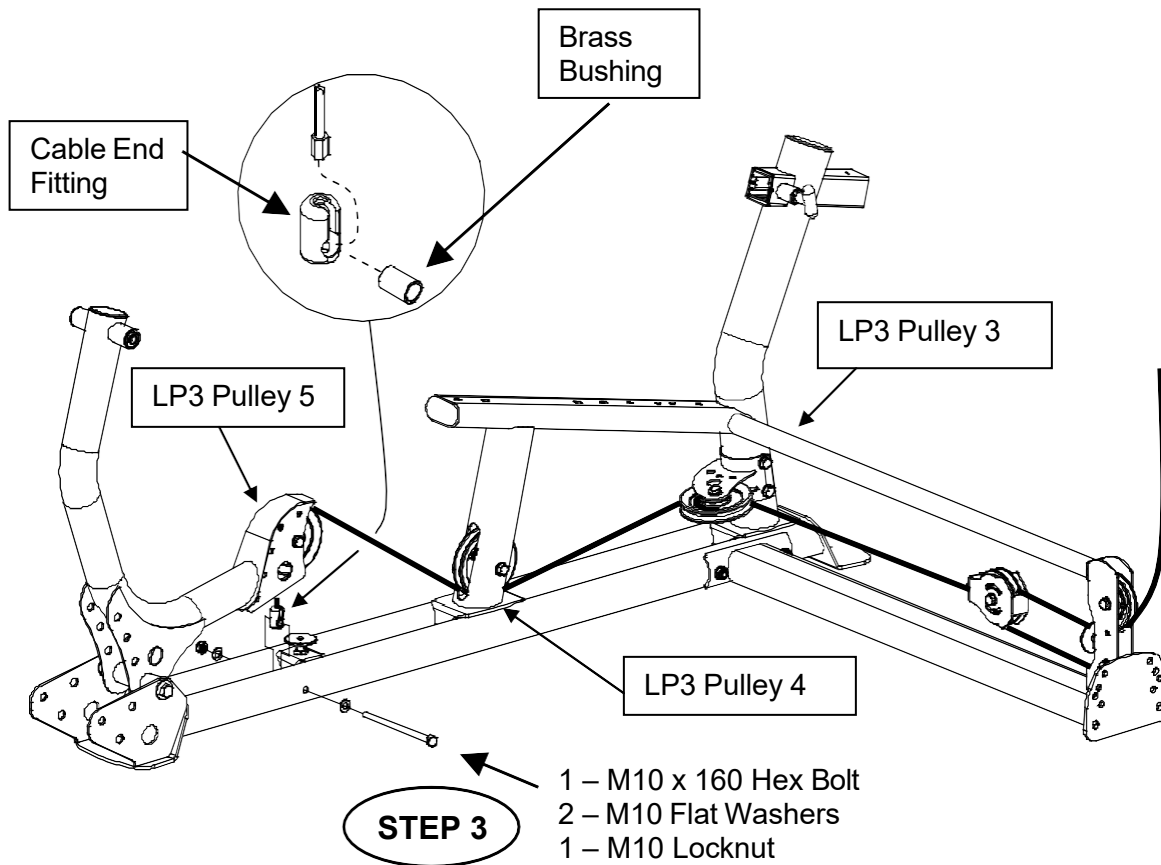

Step 3: Now, route the cable towards the back side of LP3 Pulley 3, making sure to route the cable between the pulley and the cable retainer pin. **The cable must be routed between the pin and the pulley or the Cable will be damaged.** From there, route the cable down to the bottom side of Pulley 4 as shown. From Pulley 4, go up to the top of Pulley 5 and then down the front and anchor the cable end with the Cable End Fitting and Brass Bushing as show in the highlighted circle using:

- 1 - M10 x 160 Hex Bolt
- 2 - M10 Flat Washers
- 1 - M10 Locknut

Tighten the hardware in Step 3.

STEP 6

- 6 – M10 x 25 Hex Bolts
- 12 – M10 Flat Washers
- 6 – M10 Locknuts

Foot Plate Connector Plates

Foot Plate Assembly

Stabilizer Arm

STEP 4

- 1 – 1/2" x 165 Hex Bolt
- 2 – 1/2" Flat Washers
- 1 – 1/2" Locknuts

STEP 5

- 2 – 1/2" x 165 Hex Bolts
- 4 – 1/2" Flat Washers
- 2 – 1/2" Locknuts

Step 4: Attach the Stabilizer Arm to the LP3 Base Frame using:

- 1 – 1/2" x 165 Hex Bolt
- 2 – 1/2" Flat Washers
- 1 – 1/2" Locknut

Step 5: Attach the Stabilizer Arm and Press Arm to the Foot Plate Connector Plates using:

- 2 – 1/2" x 165 Hex Bolts
- 4 – 1/2" Flat Washers
- 2 – 1/2" Locknuts

Step 6: Attach the Foot Plate Assembly to the Connector Plates using:

- 6 – M10 x 25 Hex Bolts
- 12 – M10 Flat Washers
- 6 – M10 Locknuts

Tighten the hardware in Steps 4, 5 and 6 now but make sure that the Press Arm and Stabilizer Arm move freely.

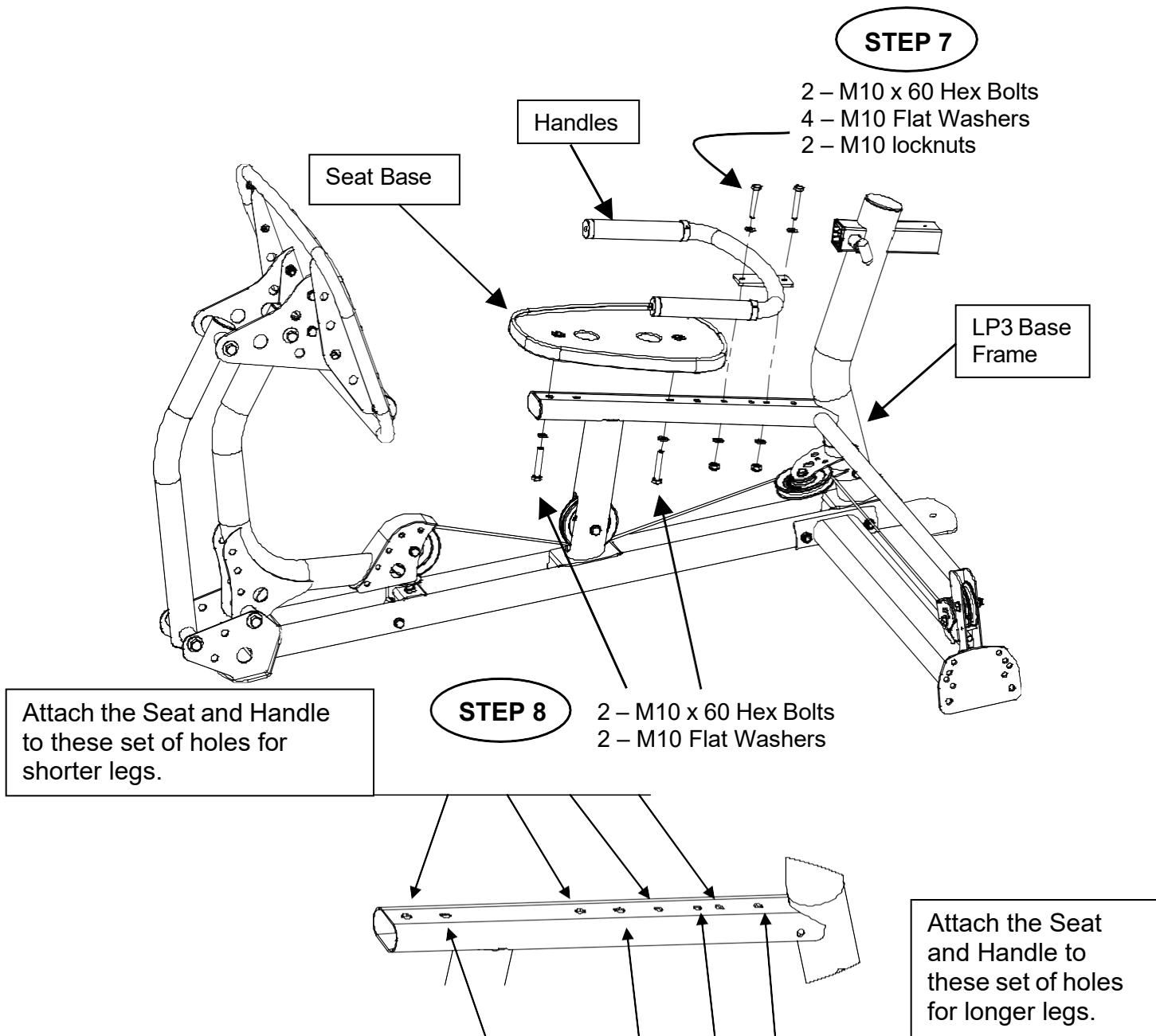

Step 7: Attach the Handles to the LP3 Base Frame using:

**2 – M10 x 60 Hex Bolts
4 – M10 Flat Washers
2 – M10 Locknuts**

Step 8: Attach the Seat Base to the LP3 Base Frame using:

**2 – M10 x 60 Hex Bolts
2 – M10 Flat Washers**

Tighten the hardware Steps 7 and 8 now but do not over tighten the hardware for the Seat Base or damage can occur.

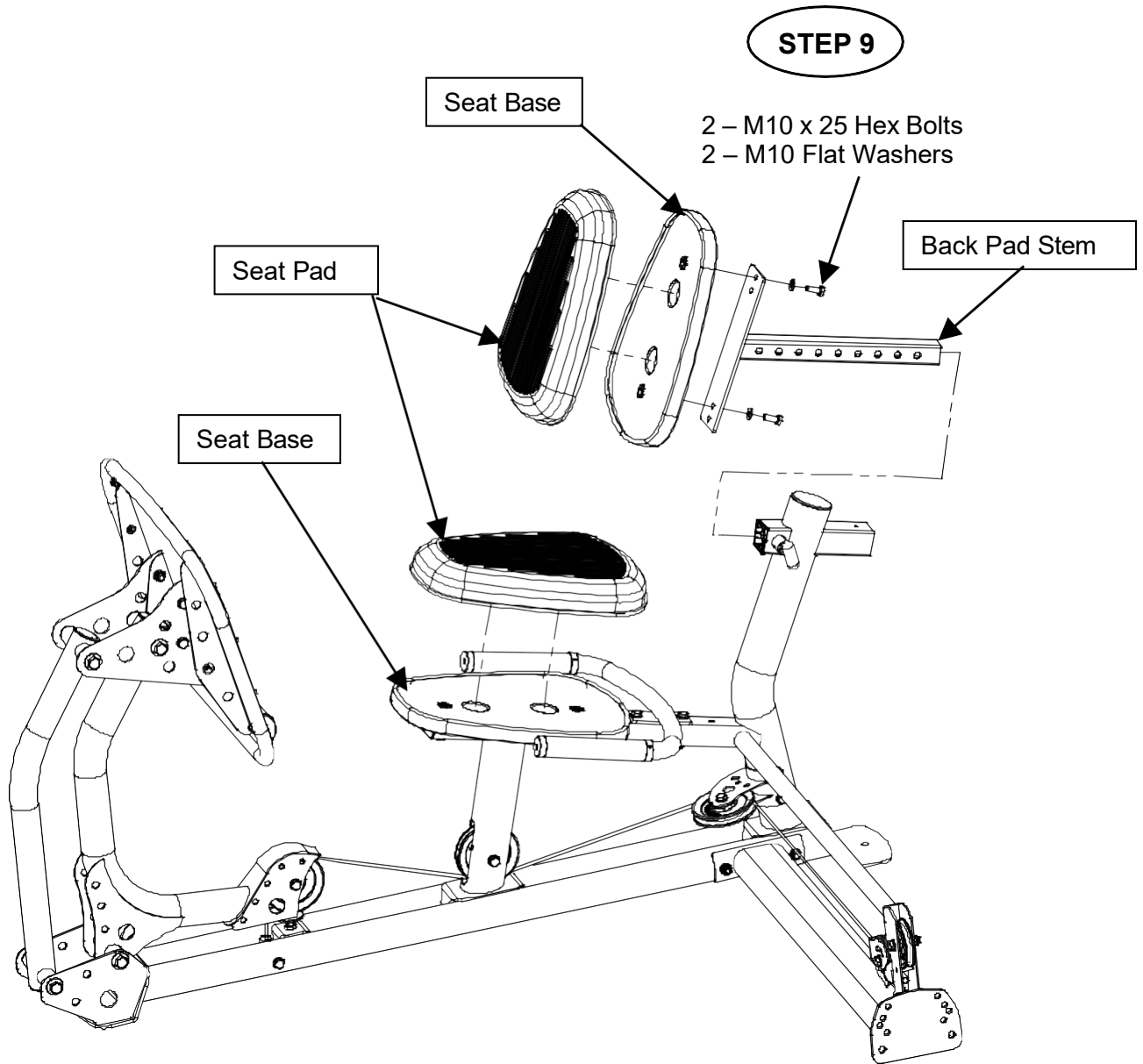

Step 9: Attach the Seat Base to the Back pad Stem using:

2 - M10 x 25 Hex Bolts
2 - M10 Flat Washers

Tighten the hardware now but do not over tighten or damage can occur to the Seat Base.

Place the Orthopedic Pads on the Seat Bases and work the edge of the pad into the groove of the Seat Base on all sides. Do not use sharp objects during installation.

Assembly Procedure for Attaching the LP3 to an M5

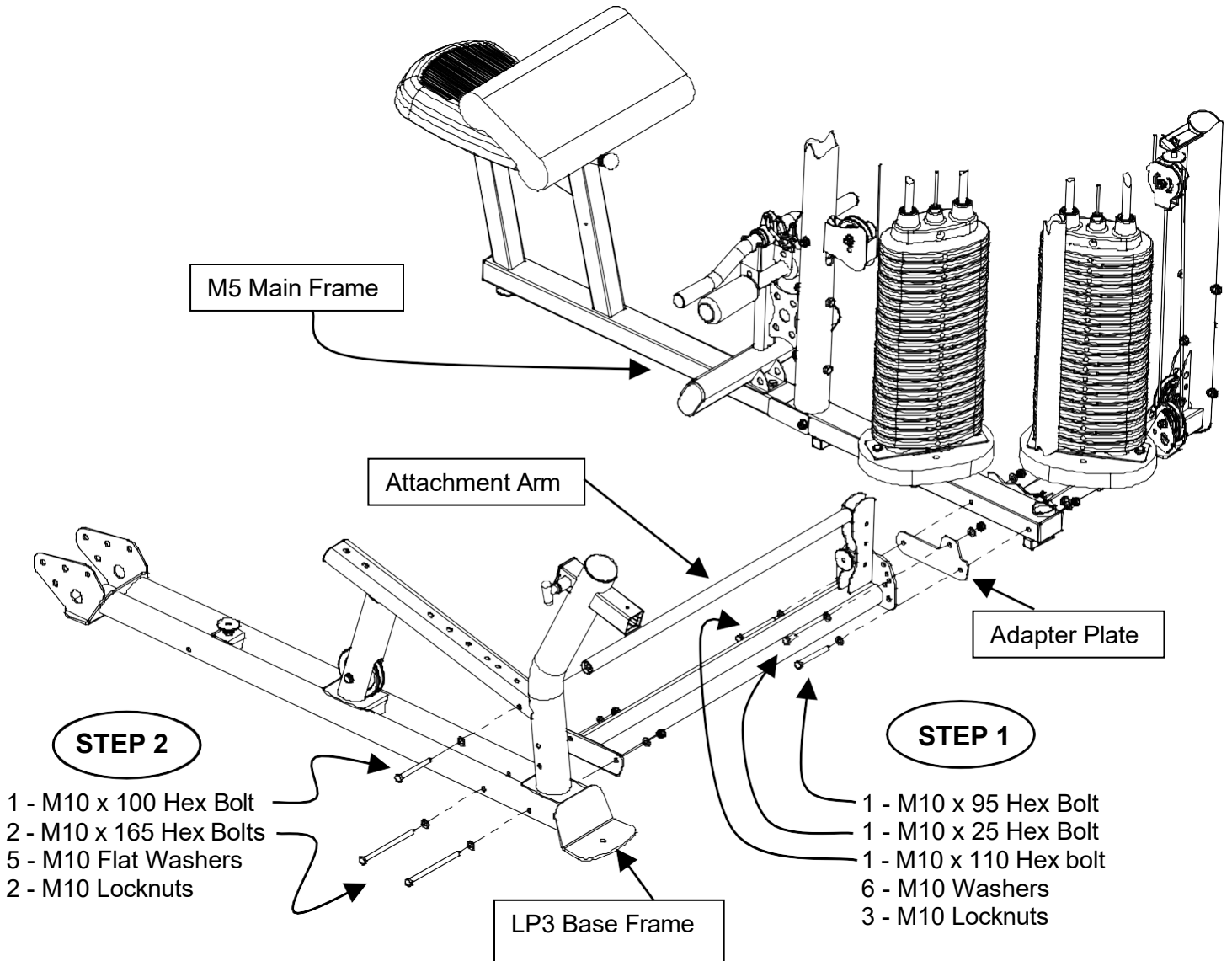

STEP 1: Attach the Attachment Arm to the M5 Main Frame using the Adapter Plate and:

Finger Tighten Only

- 1 - M10 x 95 Hex Bolt**
- 1 - M10 x 25 Hex Bolt**
- 1 - M10 x 110 Hex bolt**
- 6 - M10 Washers**
- 3 - M10 Locknuts**

STEP 2: Attach the Attachment Arm to the LP3 Base Frame using:

Finger Tighten Only

- 1 - M10 x 100 Hex Bolt**
- 2 - M10 x 165 Hex Bolts**
- 5 - M10 Washers**
- 2 - M10 Locknuts**

Assembly Procedure for Attaching the LP3 to an M5

If you are attaching the LP3 to an M5 that is already assembled, remove the Lat Upper cable and the items shown before attaching the Floating Pulley Bracket. **Note: Some items may drop down quickly as the Lat Cable is removed.**

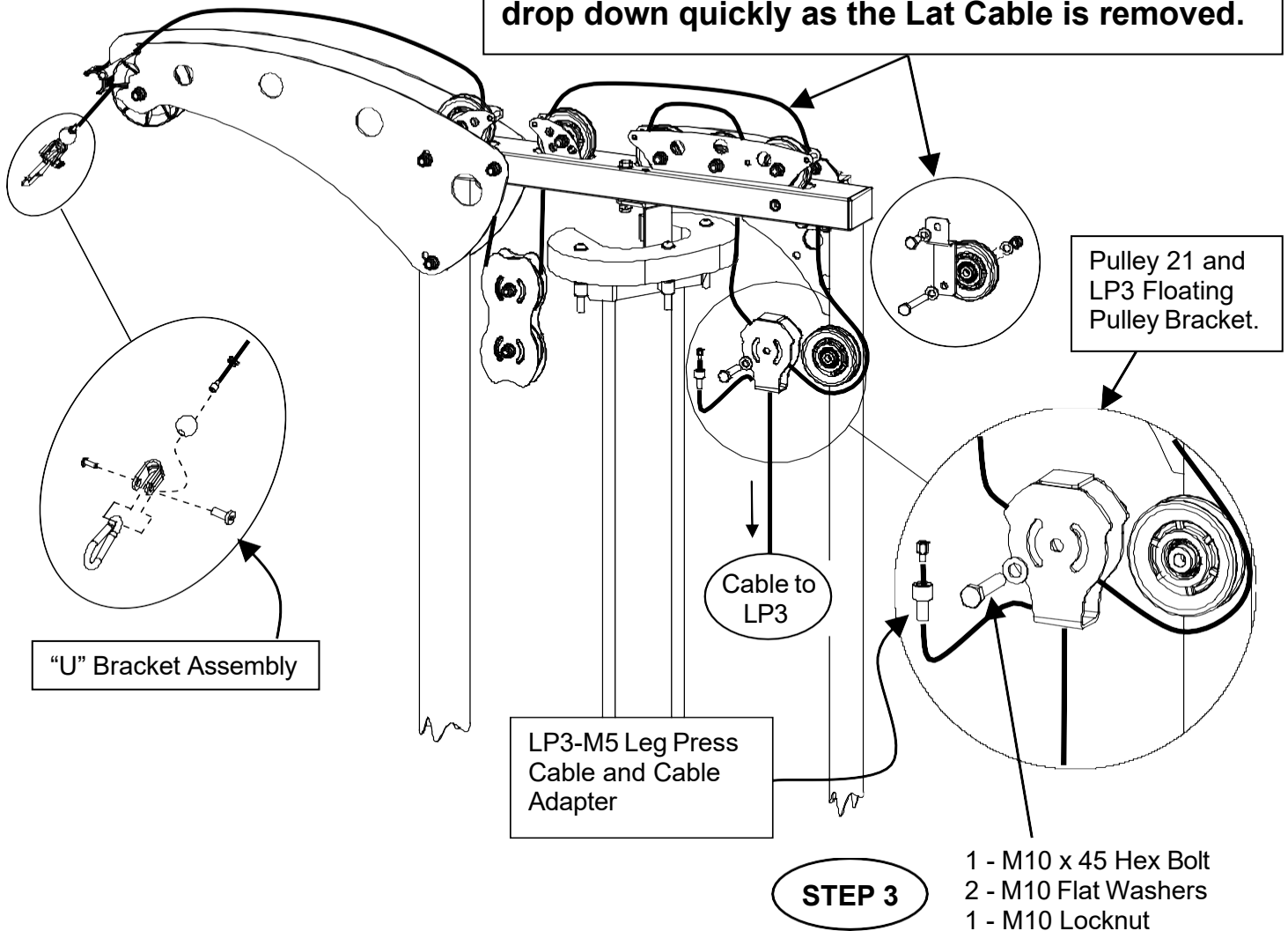

STEP 3: While installing the Lat Upper Cable, you will need to place Pulley 21 into the LP3 Floating Pulley Bracket as shown. Begin by placing the LP3-M5 Leg Press Cable end into the Floating Pulley Bracket with the Cable Adapter as shown. Then install Pulley 21 into the Floating Pulley Bracket while routing the Lat Upper Cable using:

- 1 - M10 x 45 Hex Bolt**
- 2 - M10 Flat Washers**
- 1 - M10 Locknut**

Tighten all the hardware in Steps 1, 2 and 3 at this time.

Now finish routing the Upper Cable and attaching the "U" Bracket Assembly.

Assembly Procedure for Attaching the LP3 to an M5

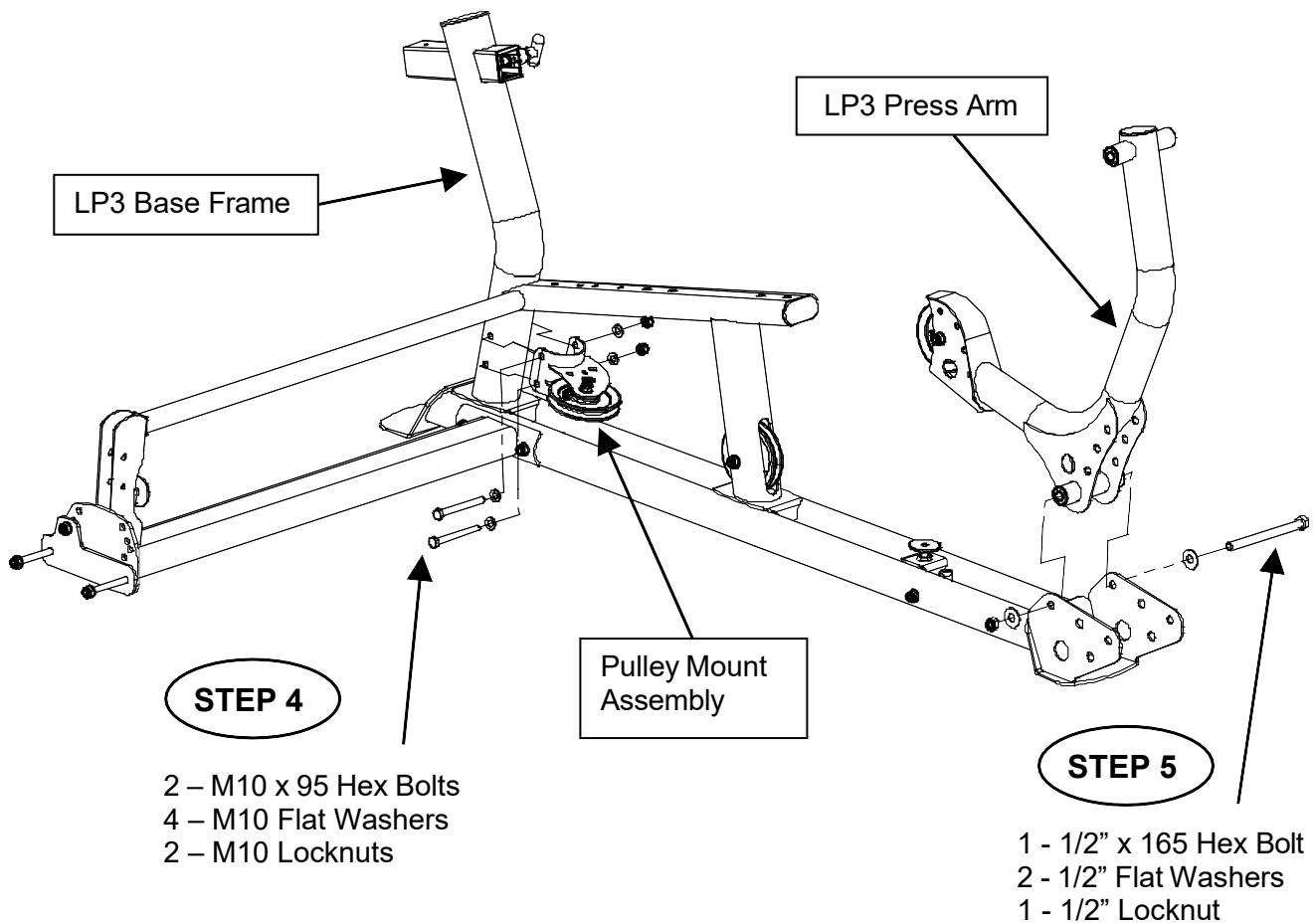

STEP 4: Attach the LP3 Pulley Mount to the LP3 Base Frame using: **2 - M10 x 95 Hex Bolts**
4 - M10 Flat Washers
2 - M10 Locknuts

STEP 5: Attach the LP3 Press Arm to the LP3 Base Frame using: **1 - 1/2" x 165 Hex Bolt**
2 - 1/2" Flat Washers
1 - 1/2" Locknut

Tighten all the hardware at this time.

Assembly Procedure for Attaching the LP3 to an M5

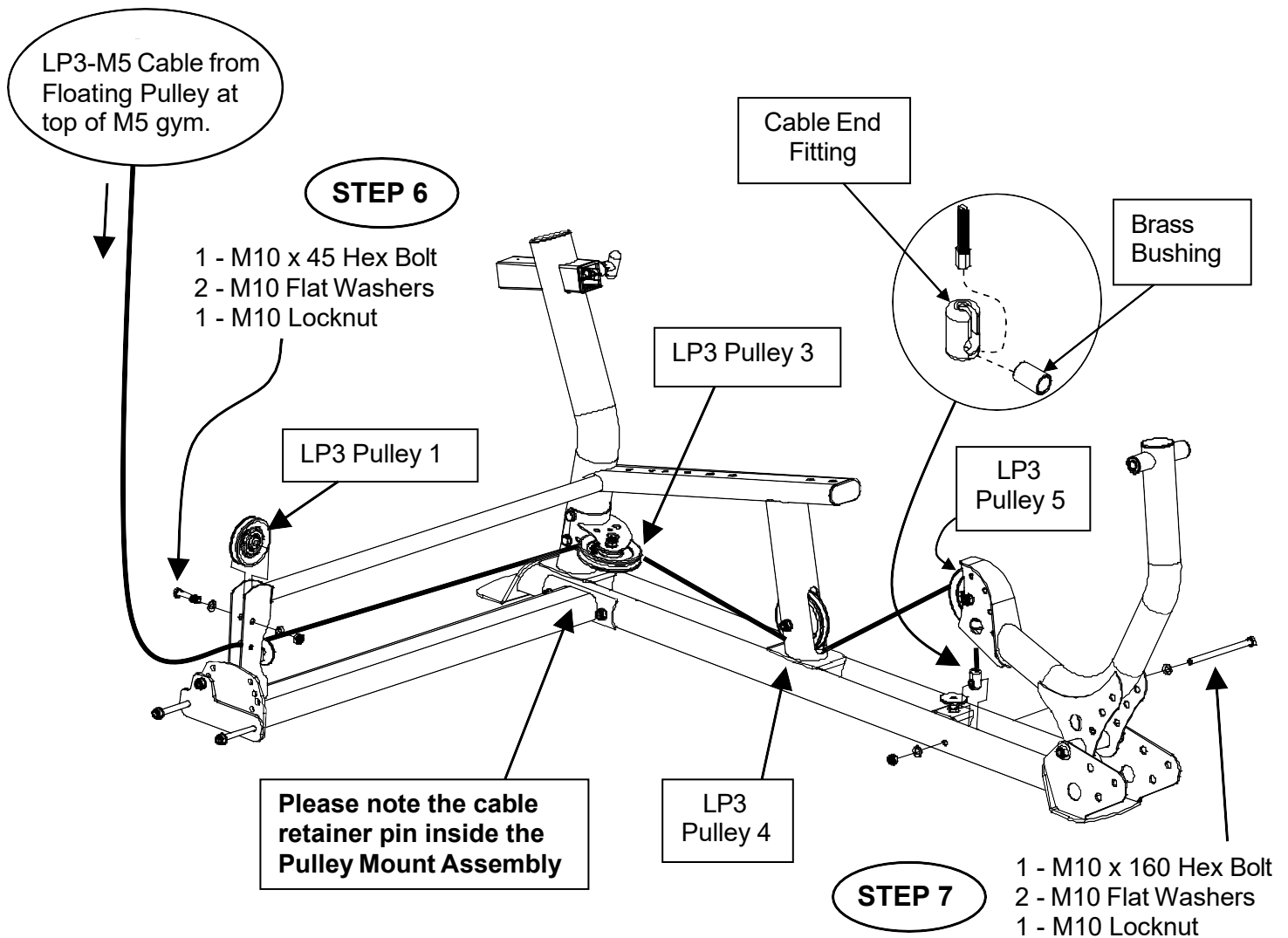

STEP 6: Continue routing the LP3-M5 Cable from the top of the M5 gym to LP3 Pulley 1. Thread the cable through the plates that holds Pulley 1 as the pulley is placed on top of the cable and bolted into place using:

- 1 - M10 x 45 Hex Bolt**
- 2 - M10 Flat Washers**
- 1 - M10 Locknut**

STEP 7: Now, route the cable towards the back side of LP3 Pulley 3, making sure to route the cable between the pulley and the cable retainer pin. **The cable must be routed between the pin and the pulley or the Cable will be damaged.** From there, route the cable down to the bottom side of Pulley 4 as shown. From Pulley 4, go up to the top of Pulley 5 and then down the front and anchor the cable end with the Cable End Fitting and Brass Bushing as show in the highlighted circle using:

- 1 - M10 x 160 Hex Bolt**
- 2 - M10 Flat Washers**
- 1 - M10 Locknut**

Tighten all the hardware at this time.

Assembly Procedure for Attaching the LP3 to an M5

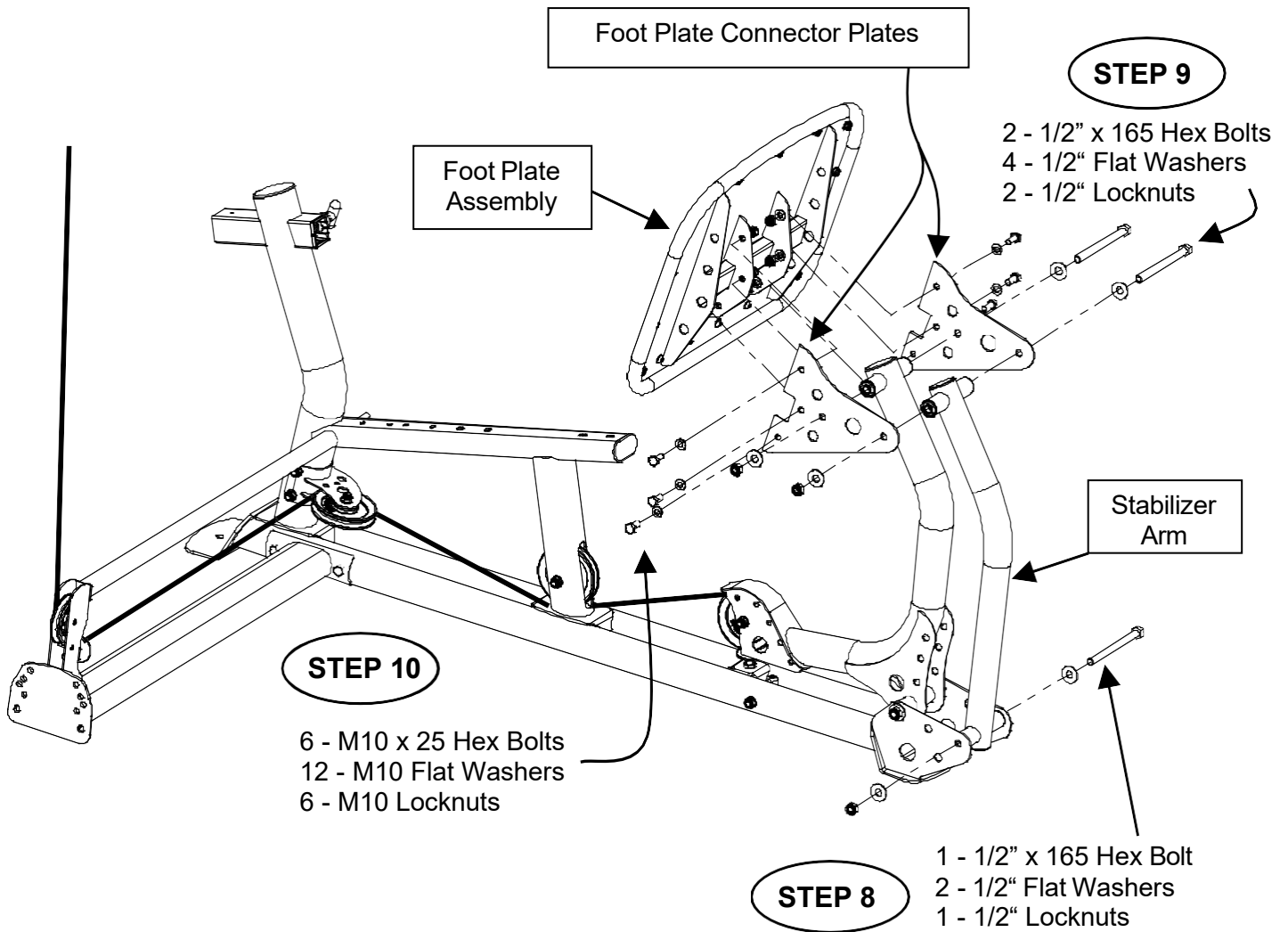

STEP 8: Attach the Stabilizer Arm to the LP3 Base Frame using:

- 1 - 1/2" x 165 Hex Bolt**
- 2 - 1/2" Flat Washers**
- 1 - 1/2" Locknuts**

STEP 9: Attach the Press Arm and Stabilizer Arm to the LP3 Base Frame and Foot Plate Connector Plates using:

- 2 - 1/2" x 165 Hex Bolts**
- 4 - 1/2" Flat Washers**
- 2 - 1/2" Locknuts**

STEP 10: Attach the Foot Plate Assembly to the Foot Plate Connector Plates using:

- 6 - M10 x 25 Hex Bolts**
- 12 - M10 Flat Washers**
- 6 - M10 Locknuts**

Tighten all the hardware at this time but make sure that the Press Arm and Stabilizer Arm move freely.

Assembly Procedure for Attaching the LP3 to an M5

STEP 11

- 2 - M10 x 60 Hex Bolts
- 4 - M10 Flat Washers
- 2 - M10 Locknuts

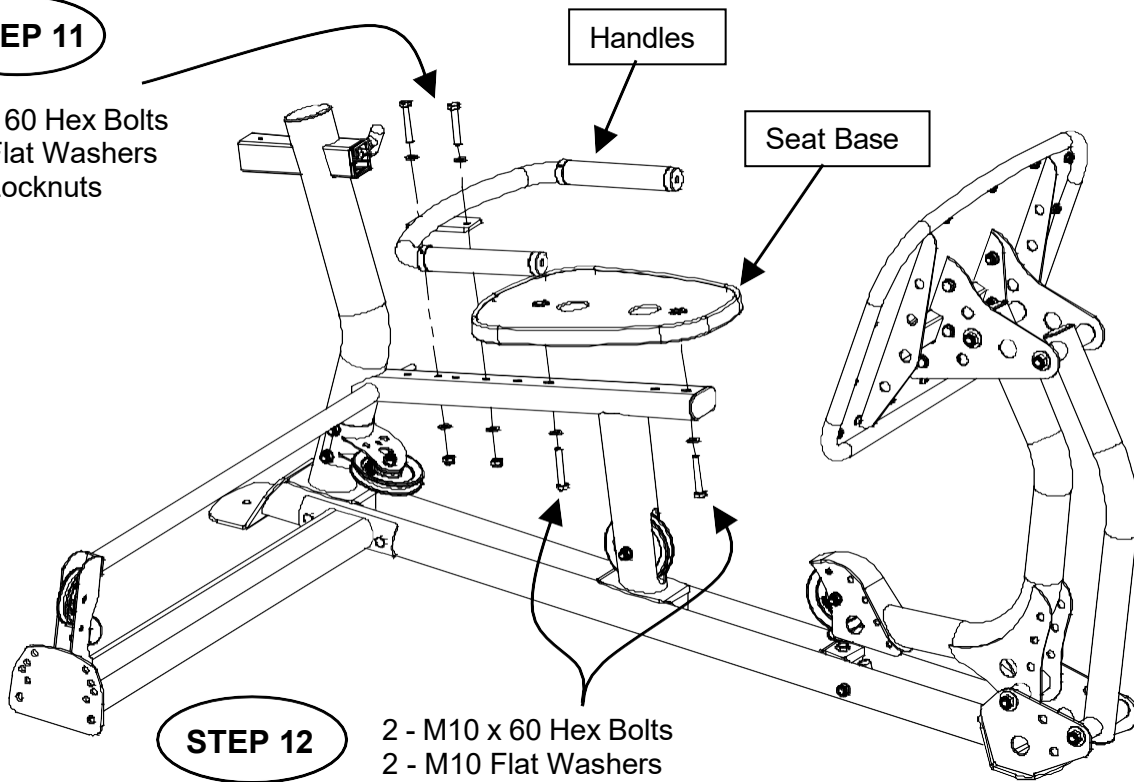

STEP 12

- 2 - M10 x 60 Hex Bolts
- 2 - M10 Flat Washers

Attach the Seat and Handle to these sets of holes for shorter legs.

Attach the Seat and Handle to these sets of holes for longer legs.

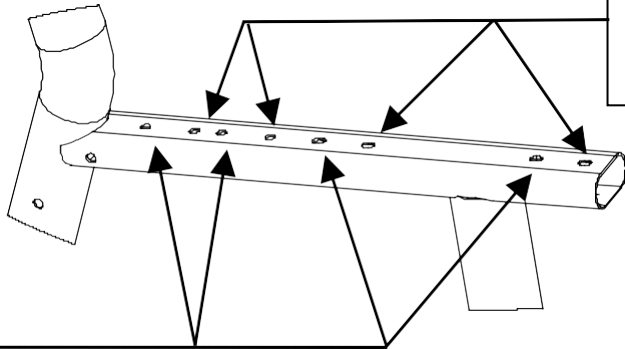

STEP 11: Attach the Handles to the LP3 Base Frame using:

- 2 - M10 x 60 Hex Bolts
- 4 - M10 Flat Washers
- 2 - M10 Locknuts

STEP 12: Attach the Seat Base to the LP3 Base Frame using:

- 2 - M10 x 60 Hex Bolts
- 2 - M10 Flat Washers

Assembly Procedure for Attaching the LP3 to an M5

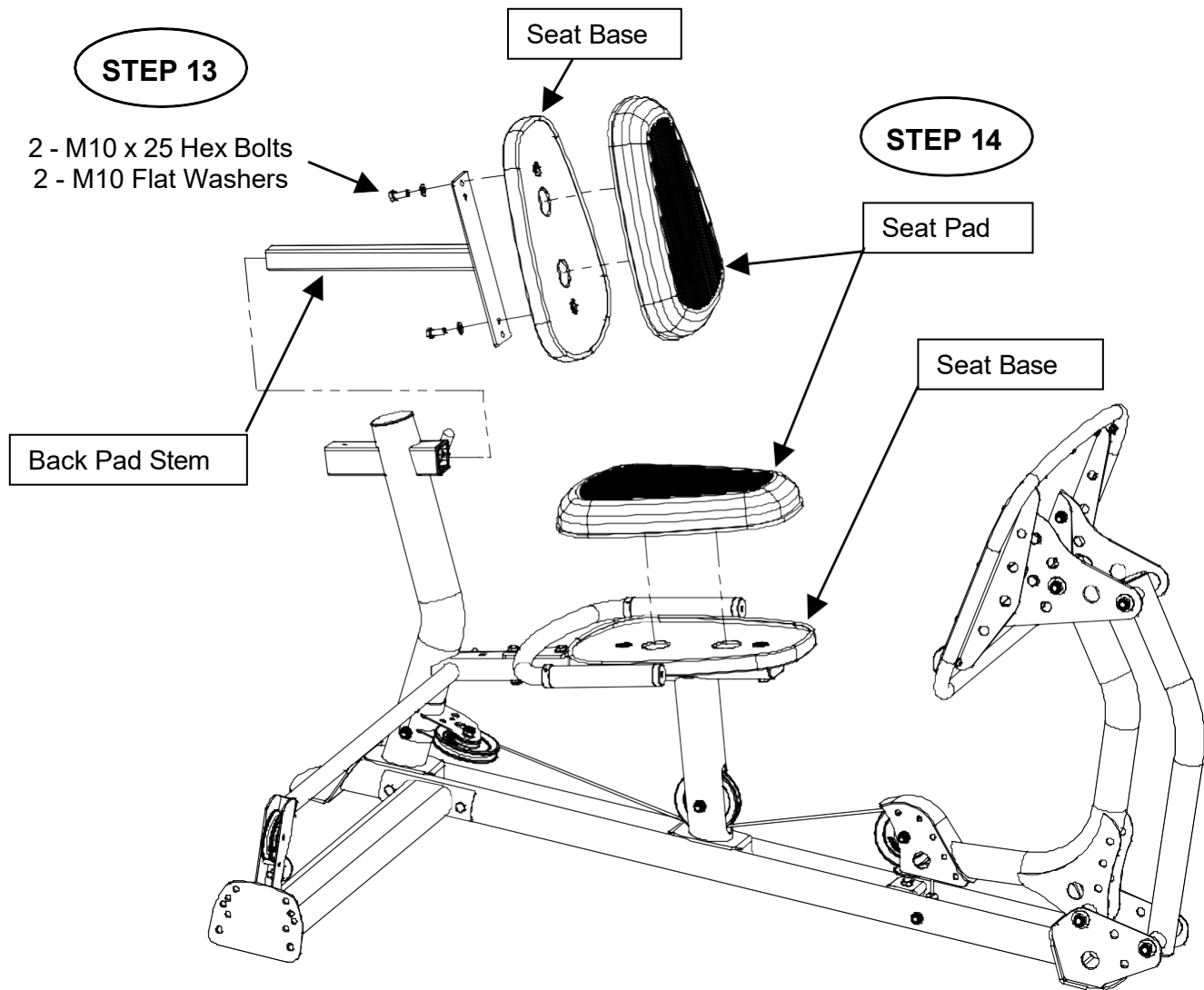

STEP 13: Attach the Seat Base to the Back Pad Stem using: **2 - M10 x 25 Hex Bolts**
2 - M10 Flat Washers

Tighten this hardware now but do not over tighten or damage can occur to the Seat Base.

STEP 14: Place the Orthopedic Pads on the Seat Bases and work the edge of the pad into the groove of the Seat Base on all sides. Do not use sharp objects during installation.

DECAL REFERENCE

NOTICE				
<i>This INSPIRE product is not intended for commercial use.</i>				
IN HOME MAINTENANCE	Weekly	3 Months	Yearly	2 Years
Inspect; Links, Pull Pins, Snap Locks, Swivels, Weight Stack Pins	X			
Clean; Upholstery	X			
Inspect; Cables and their fittings	X			
Inspect taughtness of all shrouds	X			
Inspect; Accessory Bars and Handles		X		
Inspect; All Decals		X		
Inspect; All nuts and Bolts Tighten if Needed.		X		
Inspect; Anti-Skid Surfaces		X		
Clean & Lubricate; Guide Rods with a Teflon(PTFE) based lubricant (Superlube)		X		
Lubricate; Seat Sleeves and all plastic slides		X		
Clean & Wax; All Glossy Finishes			X	
Replace; Cables, Belts and Connectin Parts.				X

INSPIRE™
 BY HEALTH IN MOTION LLC
 877-738-1729
www.inspirefitness.net
 Serial # 4-05-05-00001

This product covered by one or more of the following US Patents and others pending: 5,330,405; 5,944,641; 5,961,427; 7,645,217; 7,722,513; 7,837,600; 7,905,818; 8,096,929.

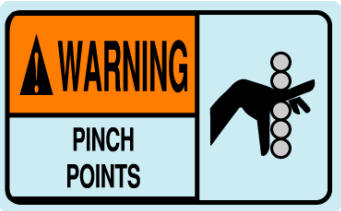

WARNING

USE ONLY GENUINE INSPIRE REPLACEMENT PARTS. FAILURE TO DO SO WILL VOID WARRANTY AND COULD RESULT IN SERIOUS INJURY. THERE IS A RISK ASSUMED BY INDIVIDUALS WHO USE THIS TYPE OF EQUIPMENT. TO MINIMIZE THE RISK, ALWAYS FOLLOW THESE RULES.

1. READ & UNDERSTAND ALL ENCLOSED INSTRUCTIONS BEFORE USING THIS EQUIPMENT.
2. INSPECT EQUIPMENT BEFORE EACH USE. Replace parts that show any wear or damage. If in doubt about a certain part, DO NOT use the equipment until the part is replaced. Failure to replace worn or damaged parts may result in injury.
3. FOLLOW MAINTENANCE SCHEDULE on the "NOTICE" sticker
4. CONSULT YOUR PHYSICIAN BEFORE STARTING ANY EXERCISE PROGRAM. Warm up properly before exercising. Stop exercising if you feel faint or dizzy.
5. TO PREVENT THE POSSIBILITY OF SERIOUS INJURY, KEEP CLEAR OF ALL MOVING PARTS. DO NOT ATTEMPT TO FREE ANY JAMMED PART BY YOURSELF. Obtain assistance in order to avoid possible injury.
6. Take your time and do not rush exercise. Practice proper breathing. NEVER hold your breath.
7. CHILDREN SHOULD NOT BE ALLOWED TO USE THIS EQUIPMENT. To avoid possible injury, children should be kept at a safe distance when this equipment is in use. Teenagers should not use this equipment without adult supervision.
8. CALL YOUR AUTHORIZED INSPIRE DISTRIBUTOR if you have any questions on the proper use or maintenance of this equipment.

DECAL PLACEMENT

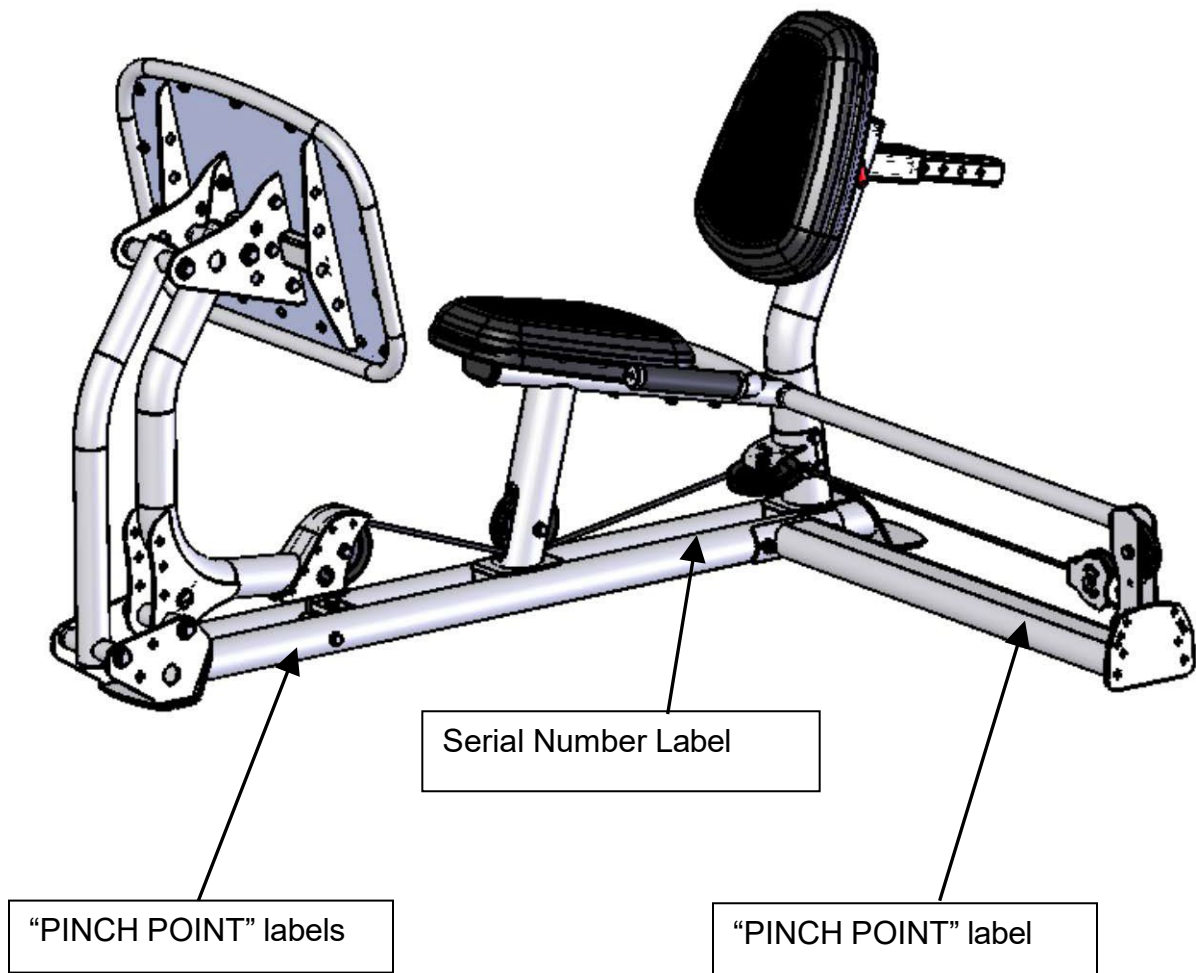

Training Tips

CONSULT A PHYSICIAN BEFORE STARTING ANY EXERCISE PROGRAM

1. **Always warm up** before you start weight training. This helps get your muscles warm and prevents injury. You can warm up with light cardio or by doing a light set of each exercise before going to heavier weights.
2. **Control the weight.** Always work with a weight that you can handle through a full range of motion. Slow and steady movements are recommended.
3. **Breathe.** Don't hold your breath during your set. Holding your breath builds internal pressure which increases your chance for broken blood vessels, as well as a hernia.
4. **Sit up straight.** Pay attention to your posture and keep everything straight. Engage your abs in every movement to keep balanced and protect your spine.

GENERAL MAINTENANCE INFORMATION

- Periodically inspect the cables for splitting, cracking or fraying. Also, watch for bulging or flat areas in the cable.
- Immediately replace cables at the first signs of damage or wear. Never use equipment with damaged or worn cables.
- Cables naturally stretch over time, so check cable slack periodically and adjust cable tension as needed.
- Regularly inspect product for loose hardware.
- Do not use or store equipment outdoors.
- Inspect snap links, swivels, handles, and weight stack pins for wear or damage. If wear or damage exists, replace immediately.
- Locate and familiarize yourself with all warning decals on the multi-gym.
- Replace damaged or worn upholstery immediately.

MAINTENANCE SCHEDULE

ROUTINE	HOME MAINTENANCE	ENTRY DATE								
Inspect: Links, Pull Pins, Spring Clips, Swivels	WEEKLY									
Clean: Upholstery	WEEKLY									
Inspect: Cables and their Fittings	WEEKLY									
Inspect: All Decals	3 MONTHS									
Inspect: All Nuts and Bolts. Tighten if Needed	3 MONTHS									
Inspect: Anti-Skid surfaces	3 MONTHS									
Lubricate: Seat Sleeves and all Plastic Slides	3 MONTHS									
Clean and Wax: All Glossy Finishes	YEARLY									
Replace: Cables, Belts and Connecting Parts	2 YEARS									

INSPIRE

Warranty.

This Warranty applies to Inspire Strength products manufactured or distributed by Health In Motion LLC.

CONSUMER USE:

LIMITED LIFETIME FRAME:

Includes Frame and Welds

LIMITED LIFETIME PARTS:

Includes Upholstery, Hardware, etc.

LIMITED LIFETIME MOVING PARTS:

Includes Pulleys, Cables, etc.

LIGHT-COMMERCIAL USE:

LIMITED LIFETIME FRAME:

Includes Frame and Welds

10 YEAR PARTS:

Includes Upholstery, Hardware, etc.

10 YEAR MOVING PARTS:

Includes Pulleys, Cables, etc.

PLEASE NOTE THAT NOT ALL INSPIRE PRODUCTS ARE MADE FOR LIGHT-COMMERCIAL USE

Refer to your Owner's Manual or consult with you fitness product dealer to establish if a Product is made for light-commercial use or not. Using a non-commercial product in a commercial setting can result in serious injury or death!

Health In Motion warrants that the Product you have purchased for light-commercial, personal, family or household use from Health In Motion LLC or from an authorized Health In Motion reseller is free from defects in materials or workmanship under normal use during the warranty period. Your sales receipt, showing the date of purchase of the Product, is your proof of the date of purchase. This warranty extends only to you, the original purchaser. It is not transferable to anyone who subsequently purchases the Product from you. It excludes expendable parts such as paint and finish. This Warranty becomes VALID ONLY if the Product is assembled / installed according to the instructions / directions included with the Product.

Replacement and repair of parts.

During the warranty period Health In Motion will, at no additional charge, repair or replace the Product if it becomes defective, malfunctions, or otherwise fails to conform with this Warranty under normal light-commercial, personal, family, or household use. In repairing the product Health In Motion may replace defective parts with, at the option of Health In Motion, serviceable used parts that are equivalent to new parts in performance, or new parts. All exchanged parts and Products replaced under this warranty will become the property of Health In Motion. Health In Motion reserves the right to change manufacturers and or specification of any part to cover any existing warranty.

Service procedures.

To obtain warranty parts, you must return the parts to Health In Motion or an authorized Health In Motion retailer in its original container (or equivalent). You must pre-pay any shipping charges, taxes, or any other charges associated with transportation of the Product. In addition, you are responsible for insuring any Product shipped or returned. You assume the risk of loss during shipment. You must present Health In Motion with proof-of-purchase documents (including the date of purchase, Model, and Serial Number). Any evidence of alteration, erasing or forgery of proof - of-purchase documents will be cause to void this Warranty. Register your warranty online visit www.inspirefitness.net

Conditions and Exceptions.

This Warranty does not extend to any Product not purchased from Health In Motion LLC or from an authorized Health In Motion reseller. This Warranty does not extend to any Product that has been damaged or rendered defective; (a) as a result of accident, misuse, or abuse; (b) by the use of parts not manufactured or sold by Health In Motion; (c) by modification of the Product; (d) as a result of service by anyone other than Health In Motion, or an authorized Health In Motion warranty service provider; (e) product that has not been properly maintained (follow maintenance schedule found on product). Should any product submitted for Warranty service be found to be ineligible, an estimate of repair cost will be furnished and the repair will be made if requested by you upon Health In Motion receipt of payment or acceptable arrangement of payment.

Disclaimer

EXCEPT AS EXPRESSLY SET FORTH IN THIS WARRANTY HEALTH IN MOTION MAKES NO OTHER WARRANTIES; EXPRESSED OR IMPLIED INCLUDING ANY IMPLIED WARRANTIES OF MERCHANTABILITY AND FITNESS FOR A PARTICULAR PURPOSE. HEALTH IN MOTION EXPRESSLY DISCLAIMS ALL WARRANTIES NOT STATED IN THIS WARRANTY. ANY IMPLIED WARRANTIES THAT MAY BE IMPOSED BY LAW ARE LIMITED TO THE TERMS OF THIS WARRANTY. NEITHER HEALTH IN MOTION NOR ANY OF ITS AFFILIATES SHALL BE RESPONSIBLE FOR INCIDENTAL OR CONSEQUENTIAL DAMAGES. HEALTH IN MOTION IS NOT RESPONSIBLE FOR THE REPAIR OR REPLACEMENT OF ANY PARTS THAT HEALTH IN MOTION DETERMINES HAVE BEEN SUBJECTED AFTER THE DATE OF MANUFACTURE TO ALTERATION, NEGLIGENCE, ABUSE, MISUSE, NORMAL WEAR & TEAR, ACCIDENT, DAMAGE DURING TRANSIT OR INSTALLATION, FIRE, FLOOD, OR ANY ACT OF GOD. SOME STATES DO NOT ALLOW LIMITATIONS ON HOW LONG AN IMPLIED WARRANTY LASTS OR THE EXCLUSION OR LIMITATION OF INCIDENTAL OR CONSEQUENTIAL DAMAGES, SO THE ABOVE LIMITATIONS OR EXCLUSION MAY NOT APPLY TO YOU. This Warranty gives you specific legal rights and you may also have other rights that may vary from state to state. This is the only express warranty applicable to Health In Motion's "Inspire" branded strength products. Health In Motion neither assumes nor authorizes anyone to assume for it any other express warranty.