

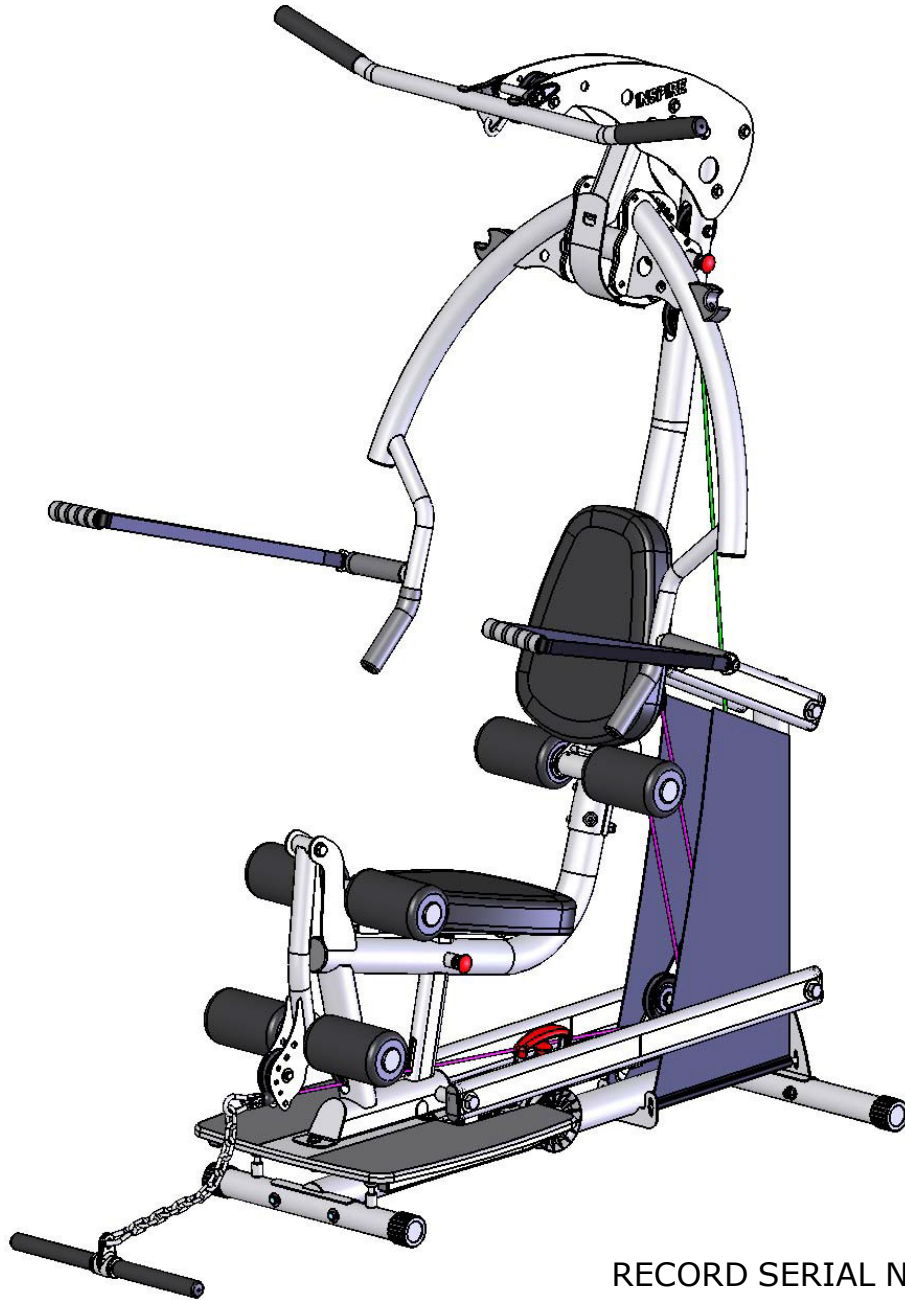

ASSEMBLY & OPERATION MANUAL



RECORD SERIAL NUMBER HERE

**CONGRATULATIONS...** You've just taken the first step to a healthier and stronger body. This home gym by Inspire offers the key to unlocking your body's potential. Regular strength training on a home gym has been shown to deliver a host of benefits including: increased muscle tone, decreased body fat, improved energy levels, a reduction in stress, and improved cardiac output. Once again, congratulations, you are on your way to improving your self image, overall health and quality of life.

## **BEFORE ASSEMBLING YOUR HOME GYM**

**IMPORTANT:** Read this entire manual before attempting to build or use this machine. This manual contains step by step instructions for proper assembly.

Use the parts list included in this manual to verify that all parts are accounted for before assembly. If any parts are missing, contact the retailer of this home gym for replacement parts. Or, call Inspire at 877-738-1729

Make sure that adequate room has been cleared before attempting to build your home gym. A rubber mat is recommended for use under your home gym to protect wood flooring or carpeting from damage during assembly and usage.

This home gym is intended for indoor use only. In addition, garages and screened in porches are not recommended due to high humidity or dust. Certain parts including guide rods can form rust in a humid environment, resulting in impaired function.

Service of your home gym should only be preformed by an authorized INSPIRE retailer. Service preformed by anyone else can result in loss of warranty. If you need help finding an authorized retailer, please contact us directly:

Inspire Fitness  
4945 East Hunter Avenue  
Anaheim, CA 92807  
Ph: 877-738-1729  
Fx: 714-738-1728  
[www.inspirefitness.net](http://www.inspirefitness.net)

# TABLE OF CONTENTS

<b>Section Description</b> .....	<b>Page</b>
Important Safety Instructions.....	1
Tools Required.....	1
Parts & Hardware List.....	2
Assembly Instructions.....	3-20
Final Adjustments.....	21
Decal Reference.....	22-23
Accessories.....	24
General Maintenance Information.....	25
Maintenance Schedule.....	26
Limited Warranty.....	27

## **IMPORTANT SAFETY INSTRUCTIONS**

Please read this entire manual and familiarize yourself with all decals and warnings before using this home gym.

- **WARNING!** It is necessary to inspect this home gym regularly to maintain safety and proper function. Please use the maintenance schedule included towards the back of this manual. Immediately replace any and all defective or worn parts. Pay special attention to moving parts such as the cables and pulleys and connections to accessories. See General Maintenance section for complete details.
- Use this home gym for its intended purpose as described in this Operation Manual or the exercise chart. Do not use attachments not recommended by the manufacturer.
- **Do not hang from press arm. The press arm is not designed to support human weight.**
- Make sure bystanders are at least 5 feet away from the home gym while it is in use.
- Keep children off the home gym at all times.
- Keep the home gym away from walls and clear of any obstructions and furniture.
- Stop immediately if you experience shortness of breath, pain, or dizziness during your workout. Inspire strongly recommends consulting your doctor before starting an exercise program.

## **TOOLS REQUIRED FOR ASSEMBLY**

- Metric socket set (including 16mm, 17mm, 18mm, 19mm, and 24mm sockets)
- 16mm, 17mm, 18mm, 19mm, and 24mm wrenches
- Adjustable wrench
- Tape Measure
- Rubber Mallet

# PARTS & HARDWARE LIST

Part #	Parts Description	Q'ty	Qty Rec'd
1	Front Foot Assembly	1	
2	Base Frame Assembly	1	
3	Rear Foot Assembly	1	
4	Shroud Mount Rod, Lower	2	
5	Shroud Mount Bracket, Upper	1	
6	Weight Selector Tube	1	
7	Slider Assembly	1	
8	Lower Arm	2	
9	Upper Arm	2	
10	Upper Main Frame Assembly	1	
11	Lower Main Frame Assembly	1	
13	Top Beam Plate	2	
14	Press Arm Mount	1	
16	Press Arm Mount Cover Plate	1	
17	Lat Bar	1	
18	Press Arm Assembly	1	
20	Backpad Tilt Frame	1	
21	Roller Tube	3	
22	Pulley Bracket, Cable Tensioner	1	
23	Seat Stem	1	
24	Leg Extension Assembly	1	
25	Revolving Straight Bar	1	
26	Chain	1	
37	Pulley Assembly, $\Phi 3 \frac{1}{2}$ "	11	
38L	Shroud, Left	1	
38R	Shroud, Right	1	
40	Step Bushing, $\Phi 12$ ID	8	
43	Large Plastic Washer	2	
44	Foam Roller	6	
45	Endcap, Roller Tube	6	
47	Pop-Pin Shaft, 140 long	1	
50	Lat Bar Holder	2	
51	Barrel Spacer, 1" Long	6	
52	Spacer Tube, 3" long	1	
53	Seat Pad	2	
65	Foot Plate Assembly	1	
68	Cable Assembly	1	
69	Cable Ball	2	
70	"U" Bracket, Cable End	2	
73	Spring Clip	3	
74	Adjustable Bumper	4	

Part#	Hardware Description	Q'ty	Qty Rec'd
77	Hex Bolt, M12*160	1	
79	Hex Bolt, M16*230	4	
81	Hex Bolt, M10*70	6	
82	Hex Bolt, M12*90	1	
83	Hex Bolt, M10*60	3	
85	Hex Bolt, M10*115	1	
86	Hex Bolt, M10*100	5	
87	Hex Bolt, M10*40	2	
88	Hex Bolt, M12*100	1	
89	Hex Bolt, M12*80	1	
90	Button Head Screw, M6*12	4	
93	Button Head Screw, M6*75	1	
94	Button Head Screw, M6*15	2	
97	Button Head Screw, M10*90	4	
98	Setscrew, M6*8	2	
99	Flathead Nut, $\phi 17*23*M6$	1	
100	Flat Head Nut, $\phi 17*25.5*M6$	2	
102	Flat Head Screw, M10*15	2	
103	Philips Head Screw, M5*12	1	
106	Cap Screw, M5*10	1	
107	Flat washer, $\Phi 10$	24	
108	Flat washer, $\Phi 12$	8	
111	Flat washer, $\Phi 40*\Phi 16.5*2.5$	8	
112	Arc Washer, $\Phi 10$	16	
116	Lock Nut, M10	19	
117	Lock Nut, M12	4	
118	Lock Nut, M16	4	
120	Allen Wrench, 3mm	1	
121	Allen Wrench, 4mm	1	
122	4-Way Po Plug Wrench, 5mm	1	
123	Allen Wrench, 6mm	1	

# ASSEMBLY INSTRUCTIONS



# STEP 1

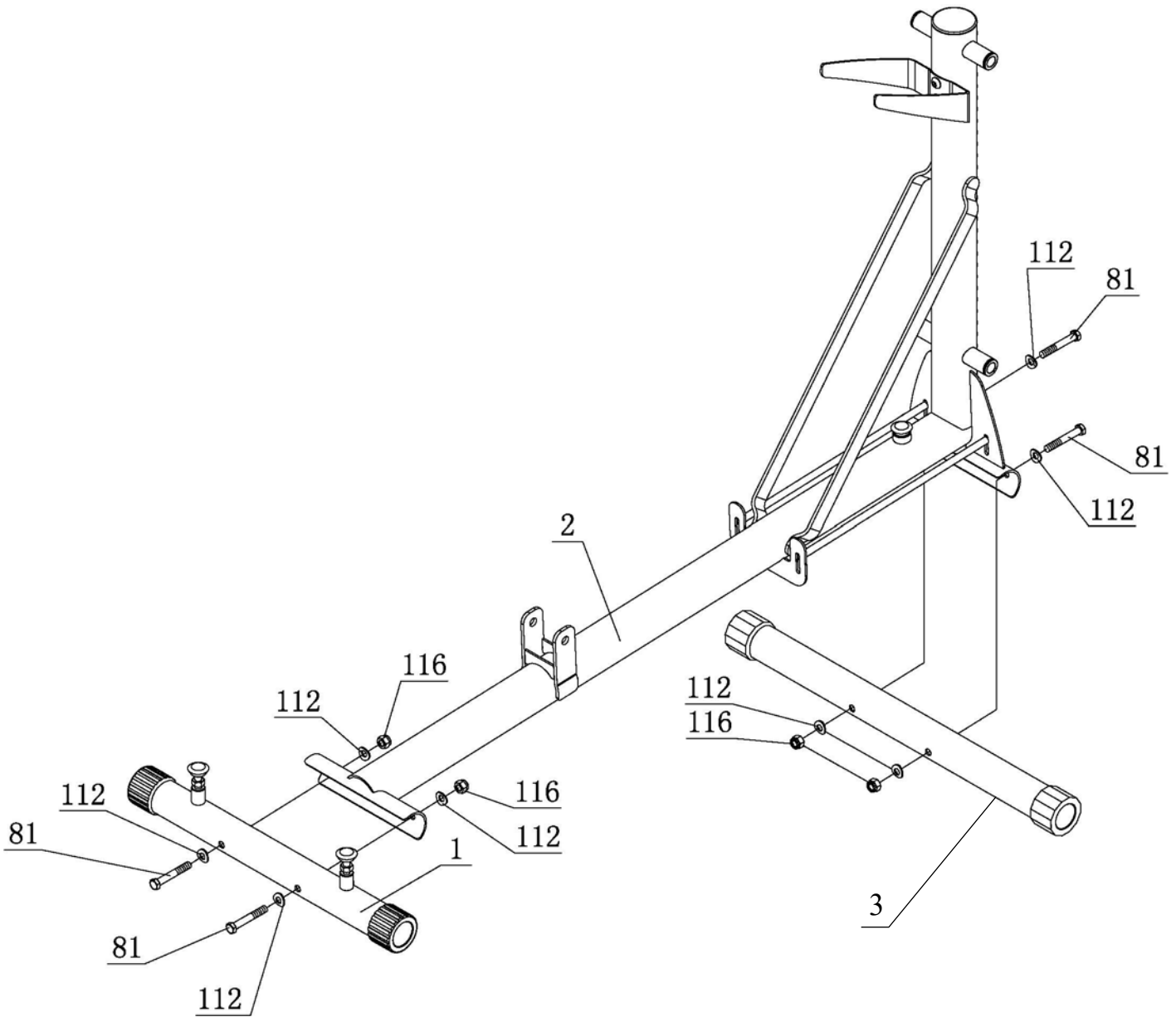

Attach Front Foot Assembly (#1) to Base Frame Assembly (#2) using: **Two (M10x70 Bolts)**

Attach Rear Foot Assembly (#3) to Base Frame Assembly (#2) using: **Two (M10x70 Bolts)**

**Wrench tighten all bolts now.**

## STEP 2

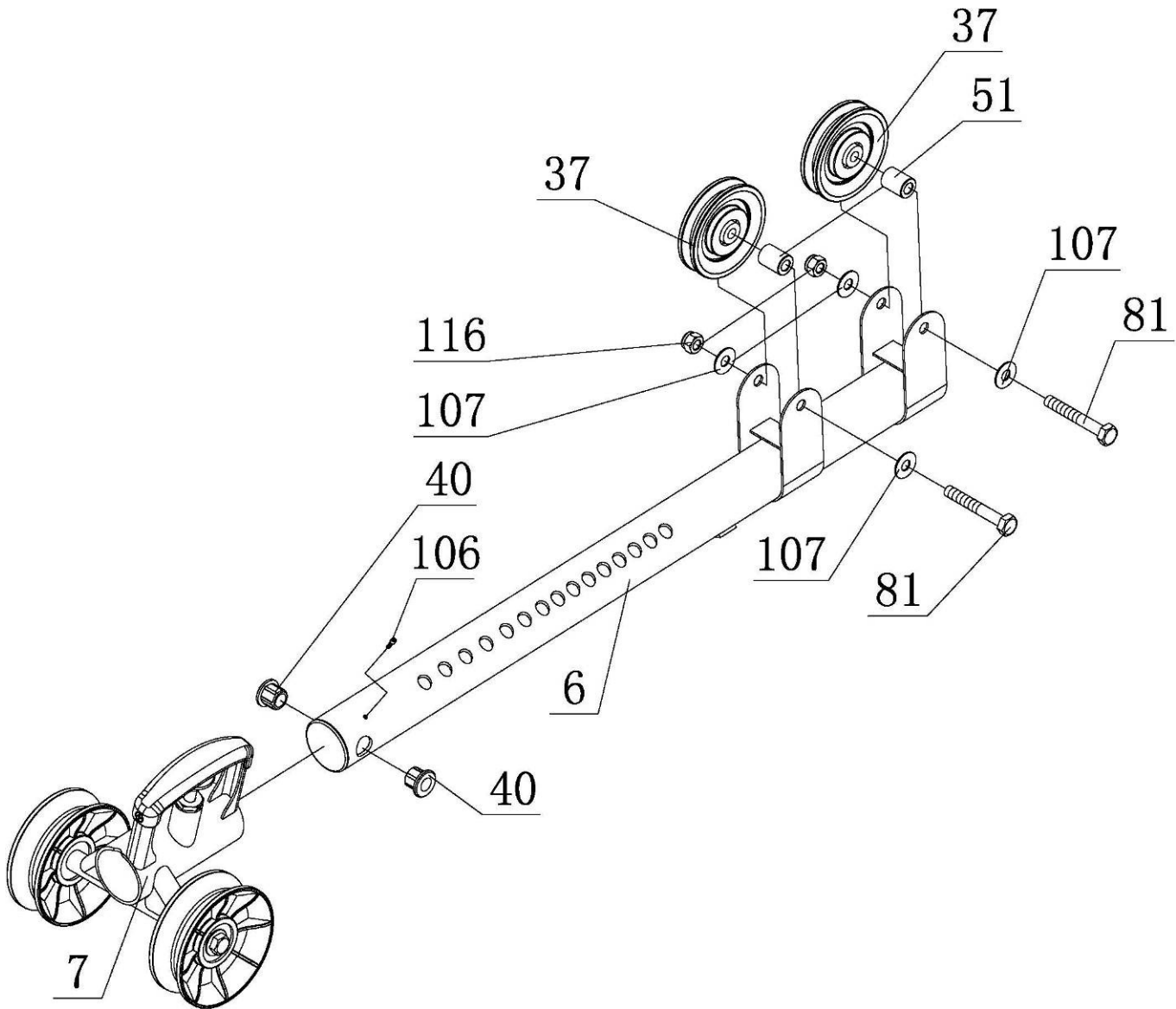

Attach Slider Assembly (#7) to Weight Selector Tube(#6).

Install M5x10 Screw (#106) into Weight Selector Stem (#6) and tighten.

Insert two Step Bushings (#40) into the Weight Selector Tube (#6).

Attach two 3 ½" Pulleys (#37) and two 1" long Barrel Spacers (#51) to Weight Selector Tube (#6) using:

**Two (M10x70 Bolts)**

**Wrench Tighten Bolts Now.**

## STEP 3

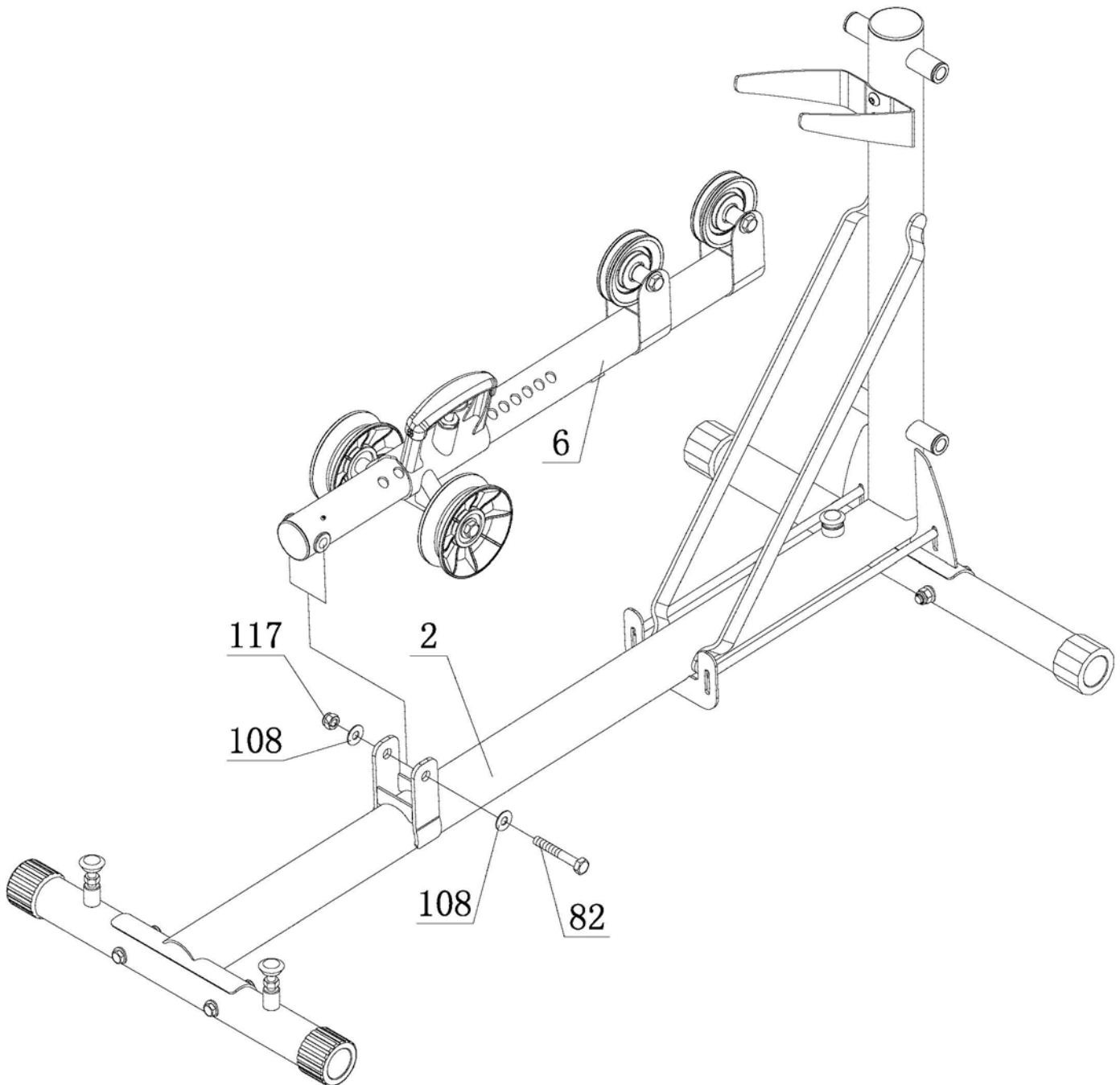

Attach Weight Selector Tube (#6) to Base Frame Assembly (#2) using:

**One (M12x90 Bolt)**

**Wrench tighten bolt so there is a slight drag when moving Weight Selector Tube. Do not over tighten.**

## STEP 4

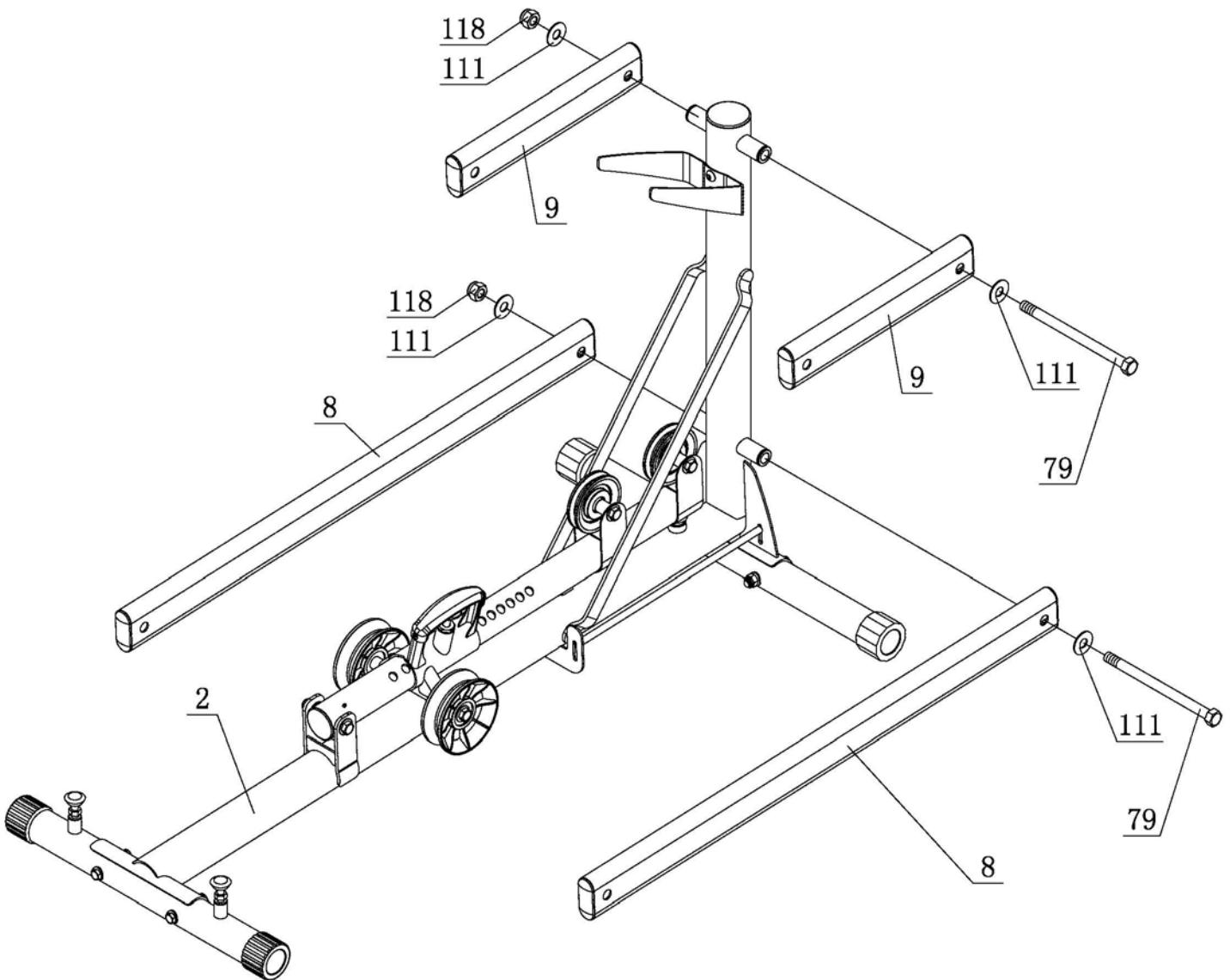

Attach Lower Arms (#8) to Base Frame Assembly (#2) using: **One (M16x230 Hex Bolt)**

Attach Upper Arms (#9) to Base Frame Assembly (#2) using: **One (M16x230 Hex Bolt)**

**Wrench Tighten bolts so there is a slight drag on the Arms when moved.  
Do not over tighten.**

## STEP 5

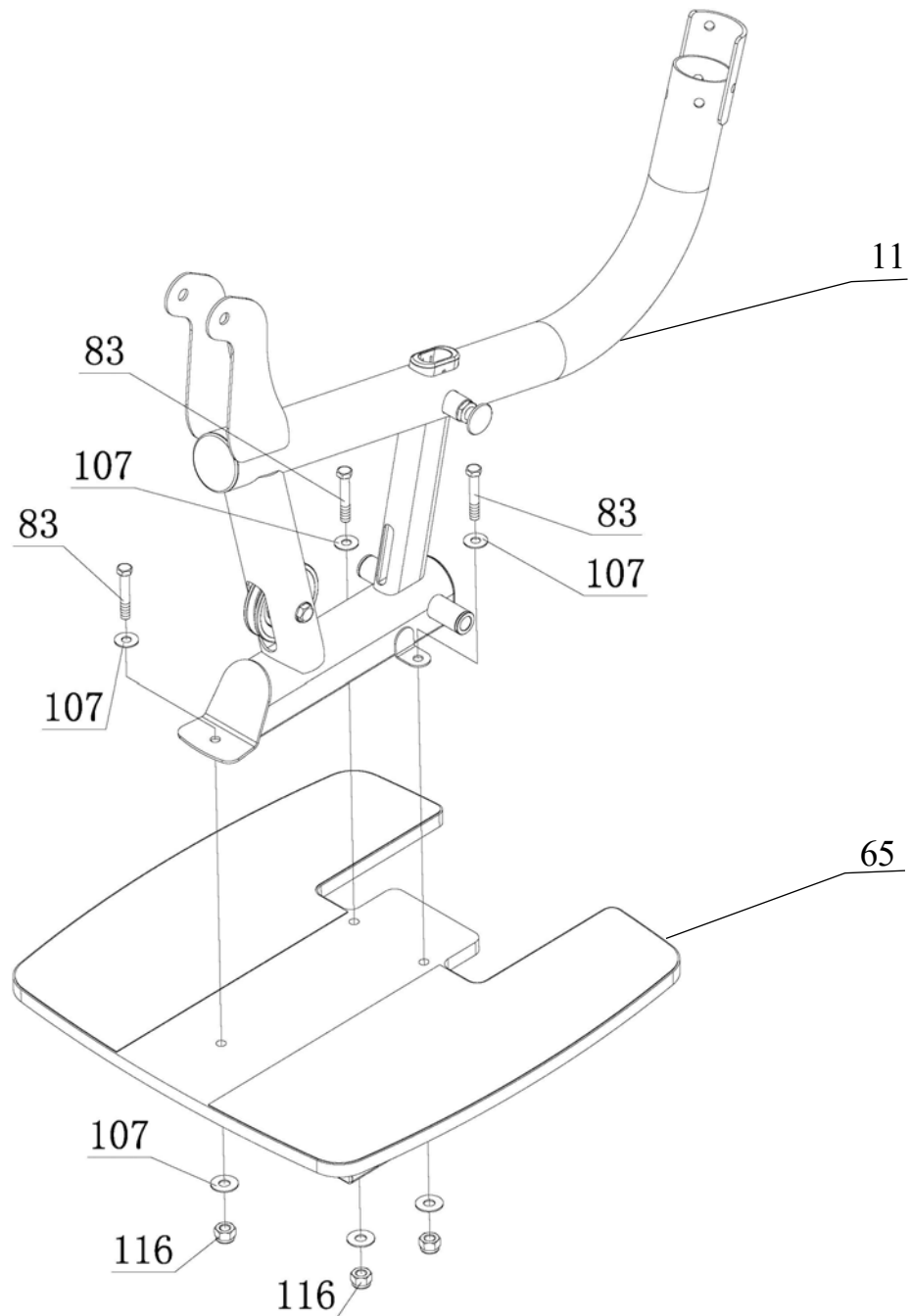

Attach Lower Main Frame (#11) to Foot Plate (#65) using: **Three (M10x60 Hex Bolt)**

**Wrench Tighten Now.**

## STEP 6

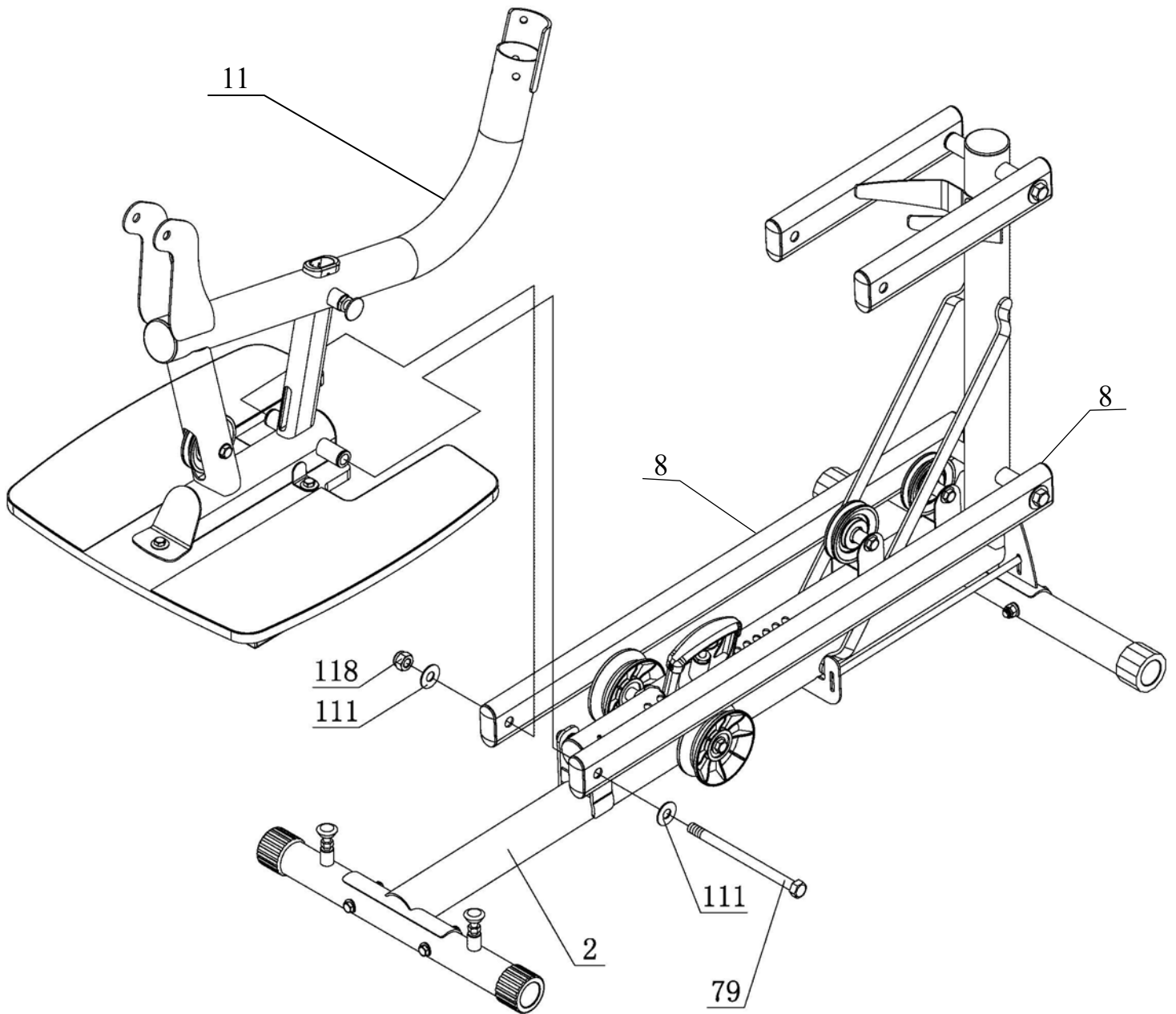

Attach Lower Main Frame (#11) to Lower Arms (#8) using: **One (M16x230 Hex Bolt)**

**Wrench Tighten bolt so there is a slight drag when moving Lower Main Frame. Do not over tighten .**

## STEP 7

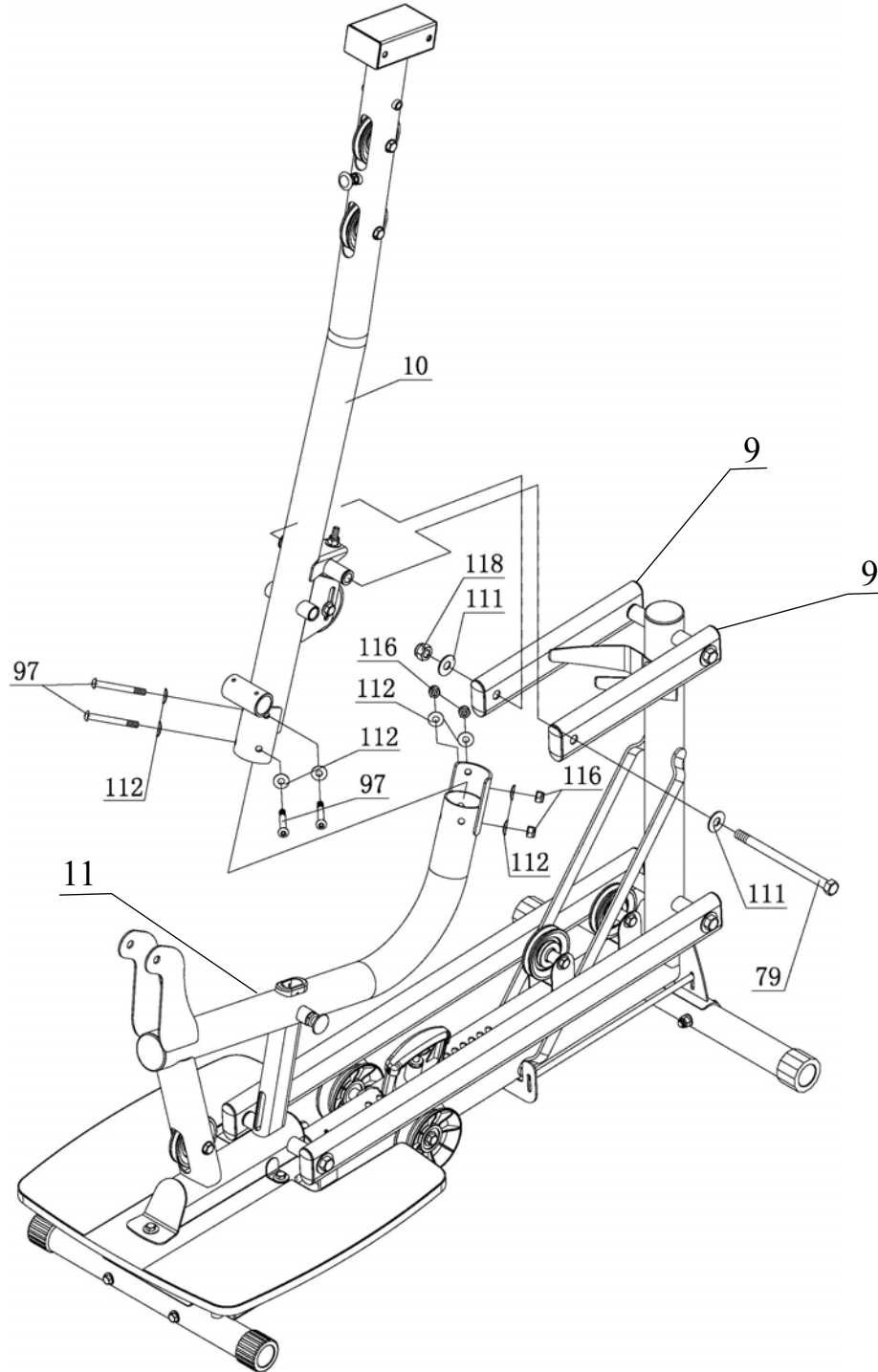

Attach Upper Main Frame (#10) to Lower Main Frame (#11) using:

**Four (M10\*90 Allen Head Screws)**

Attach Upper Main Frame (#10) to Left & Right Upper Arms (#8 & #9) using:

**One (M16\*230 Hex Bolt)**

**Wrench tighten bolts now.**

## STEP 8

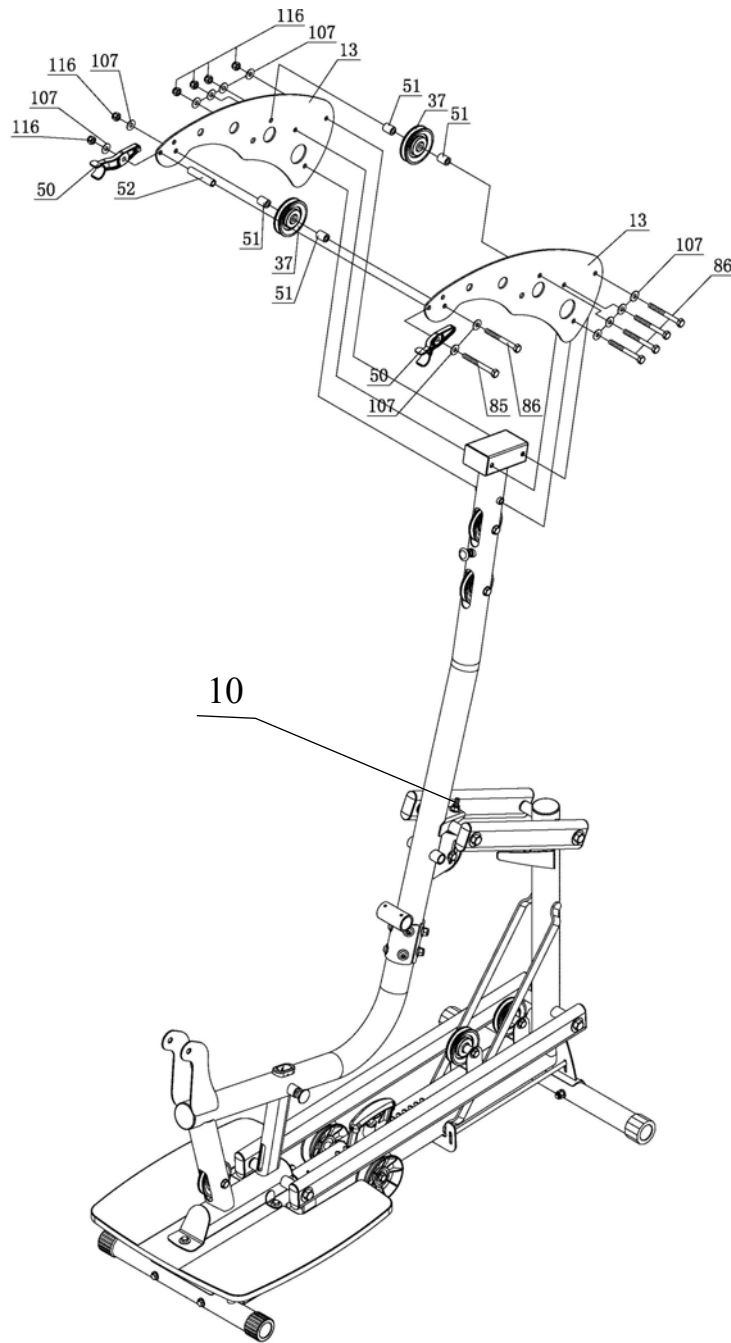

Attach Top Beam Plates (#13) and One 3 ½" Pulley (#37) to Upper Main Frame (#10) using:  
**Four (M10\*100 Hex Bolts)**  
**Two (1" Long barrel Spacers)**  
**Finger Tighten Only**

Attach Lat Bar Holders (#50) and One 3 ½" Pulley (#37) to Top Beam Plates (#13) Using:  
**One (M10\*115 Hex Bolt)**  
**One (M10\*100 Hex Bolt)**  
**One (3" Spacer Tube)**  
**Two (1" Long barrel Spacers)**

**Finger tighten bolts only. No not wrench tighten until after step 9.**

## STEP 9

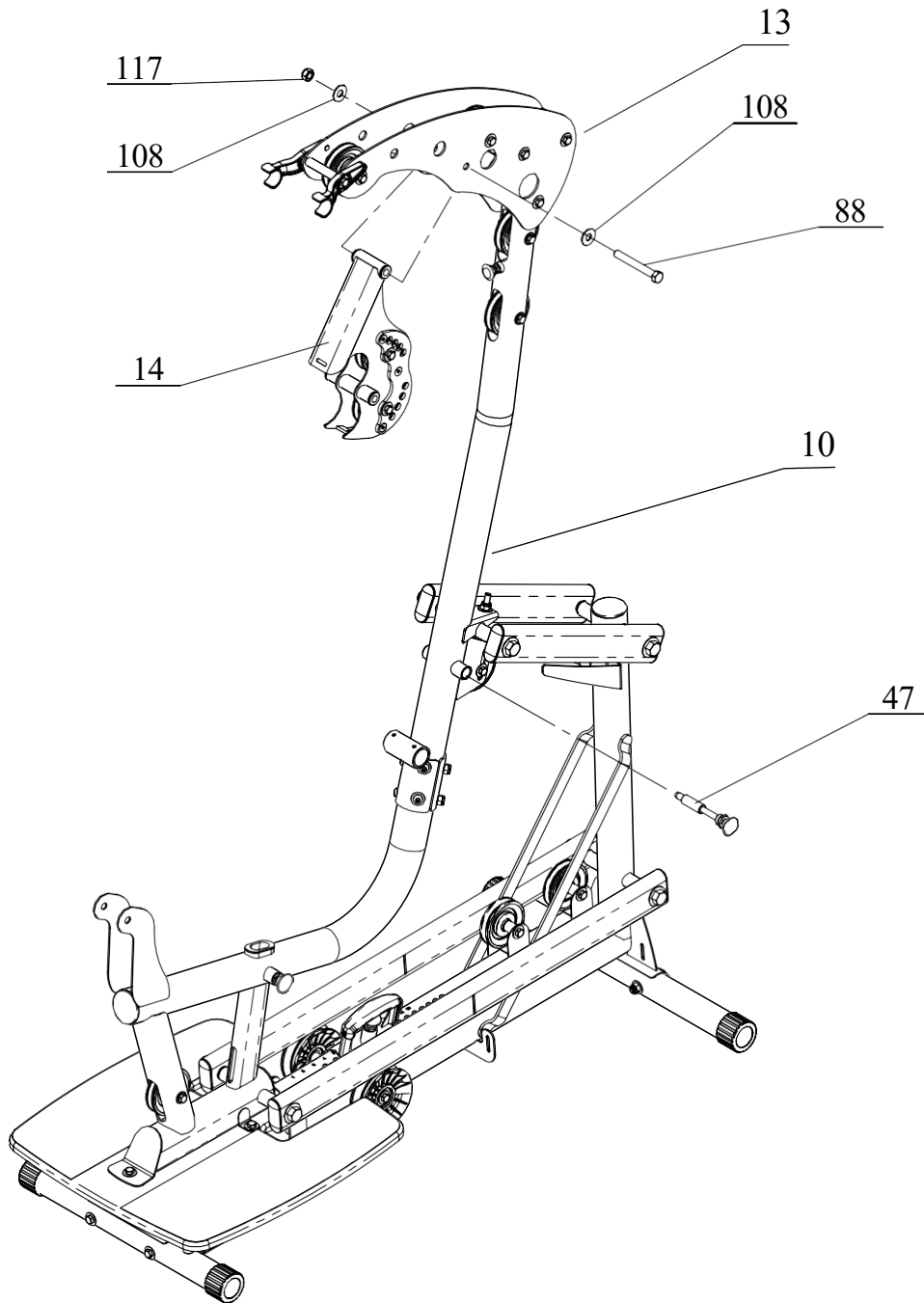

Attach Press Arm Mount (#14) to Top Beam Plates (#13) using: **One (M12\*100 Hex Bolt)**

**Wrench Tighten bolt #88 so there is a slight drag when moving Press Arm Mount. Do not over tighten .**

**Wrench tighten all bolts installed in Step 8.**

Attach Pop-Pin Shaft (#47) to Upper Main Frame (#10)

**Thread Completely and Wrench Tighten.**

## STEP 10

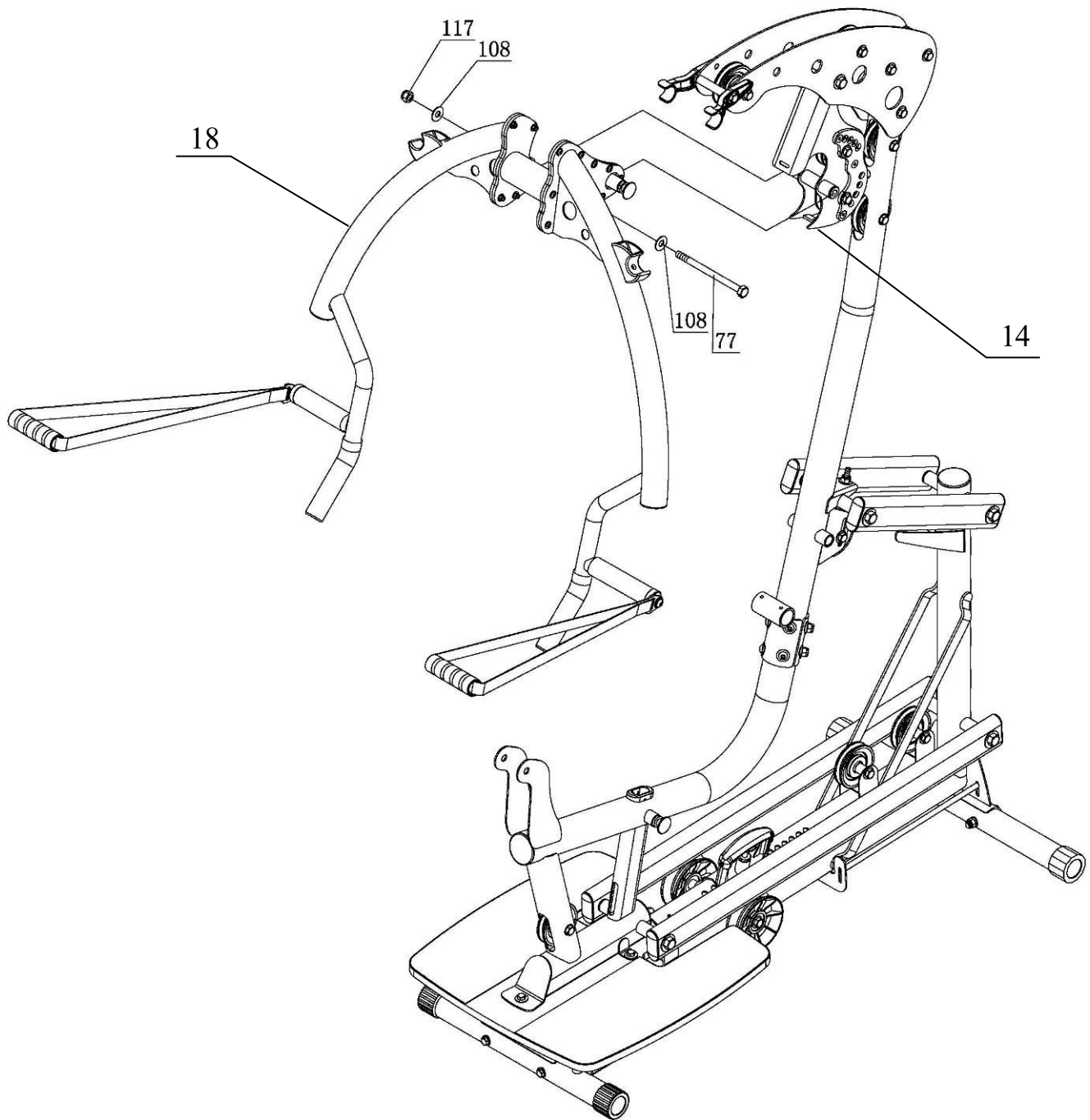

Attach Press Arm (#18) to Press Arm Mount (#14) using: **One (M12\*160 Hex Bolt)**

**Wrench Tighten bolt so there is a slight drag when moving Press Arm.  
Do not over tighten .**

## STEP 11

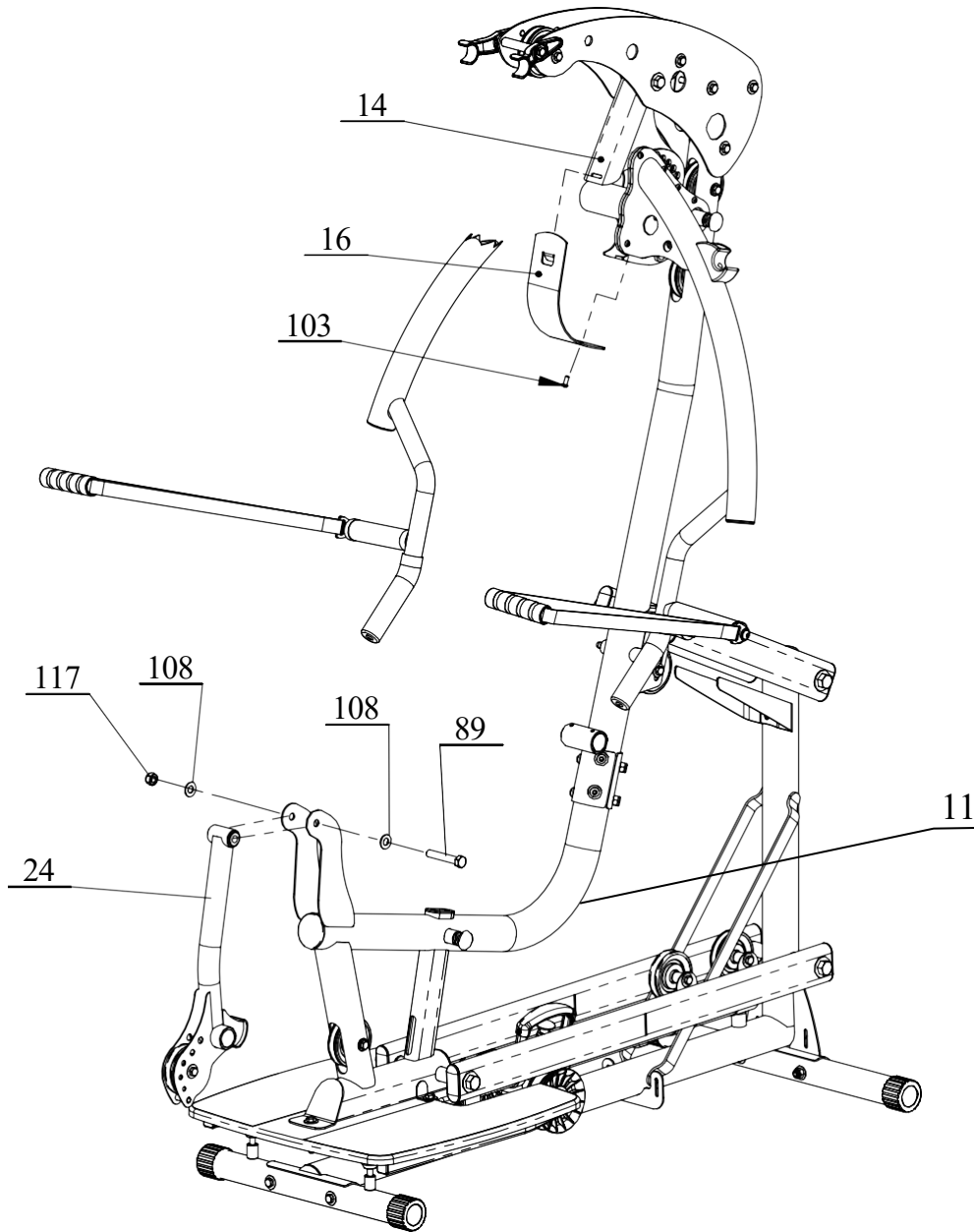

Attach Leg Extension Assembly (#24) to Lower Main Frame (#11) using:

**One (M12\*80 Hex Bolt)**

**Wrench Tighten bolt so there is a slight drag when moving Leg Extension Assembly. Do not over tighten .**

Attach Press Arm Mount Cover Plate (#16) using: **One (M5\*12 Philips head Screw)**

**Wrench Tighten Now.**

## STEP 12

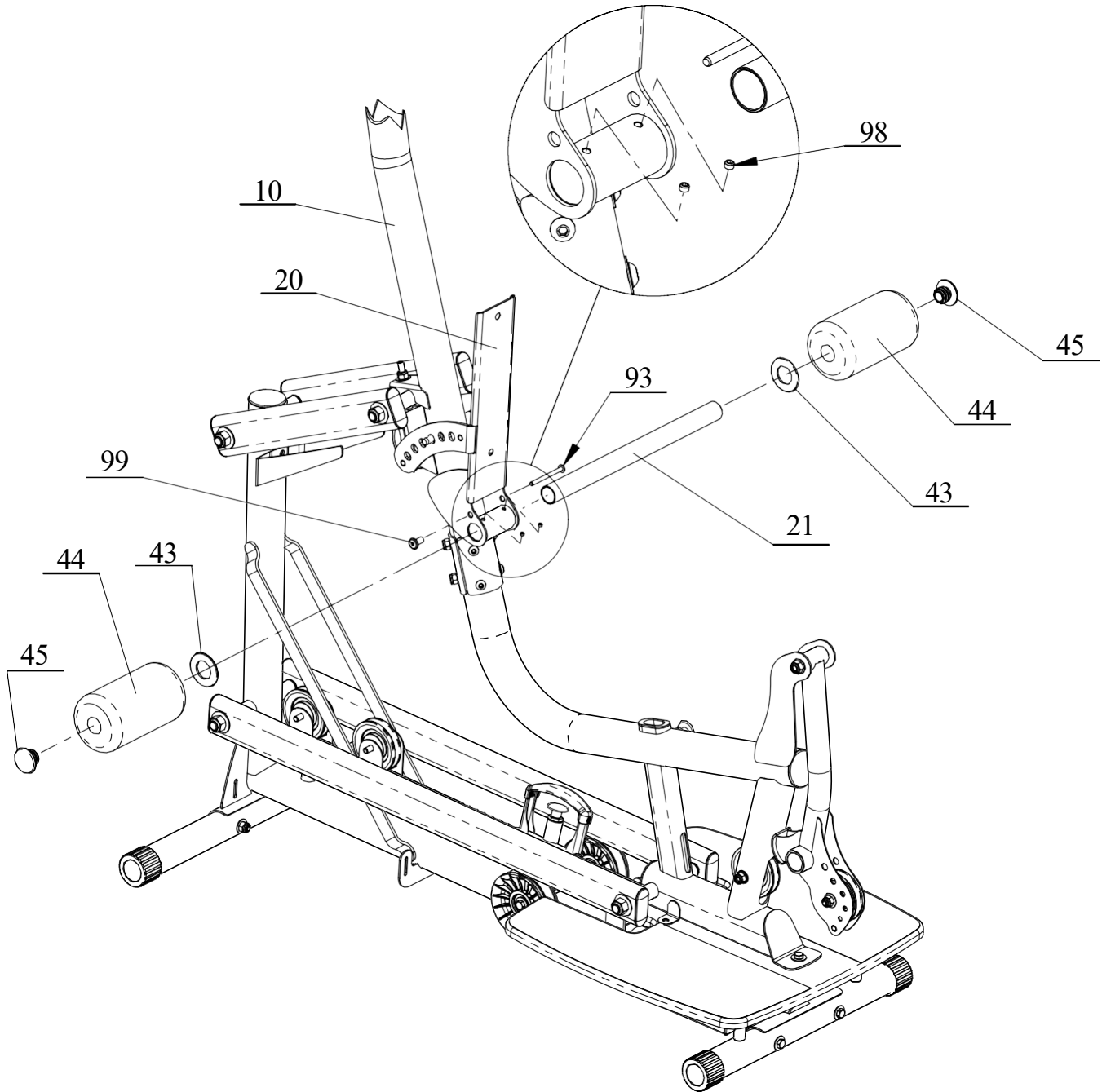

Attach Back Pad Tilt Frame (#20) to Upper Main Frame (#10) using:

**One Roller Tube (#21)**

**Two Foam Rollers (#44)**

**Two Large Plastic Washers (#43)**

**Two End Caps (#45)**

**Two M6\*8 Set Screws (#98)**

**One M6\*75 Button Head Screw (#93)**

**One M6 Flat Head Nut (#99)**

**Wrench Tighten bolt #93 so there is a slight drag when moving Back Pad tilt Frame. Do not over tighten .**

**Note: Tighten the two set screws(#98) completely after Foam Rollers are installed.**

## STEP 13

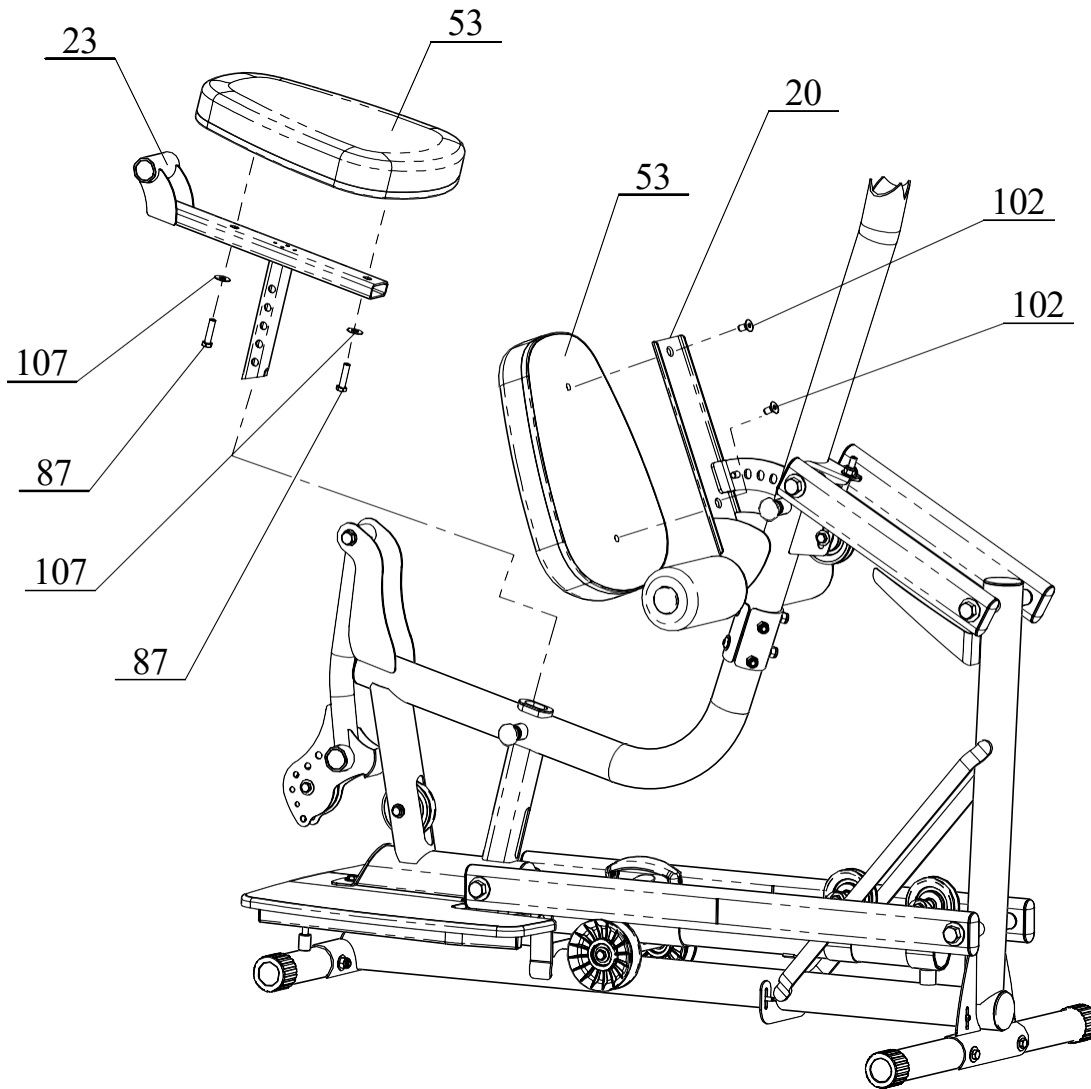

Attach Seat Pad (#53) to Seat Stem (#23) using: **Two (M10\*40 Hex Bolts)**  
**Wrench Tighten Now.**

Slide Seat Stem (#23) into Lower Main Frame (#11)

Attach Back Pad (#53) to Backpad Tilt Frame (#20) using: **Two (M10\*15 Flat Head Screws)**  
**Wrench Tighten Now.**

# STEP 14

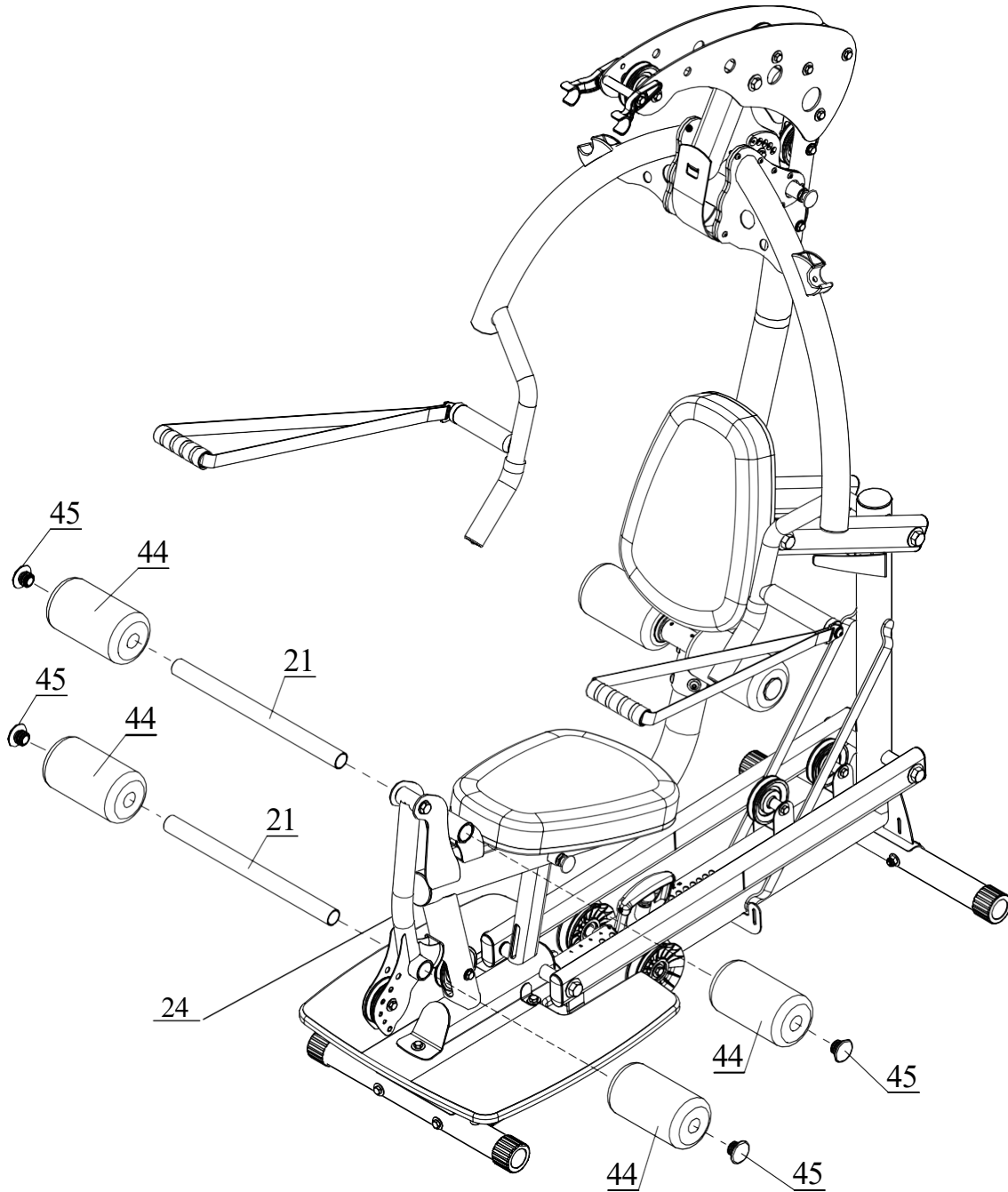

Attach 4 Foam Rollers (#44) to Leg Extension Assembly (#24) & Seat Stem (#23) using:  
**Two Roller Tubes (#21)**  
**Four End Caps (#45)**

## STEP 15

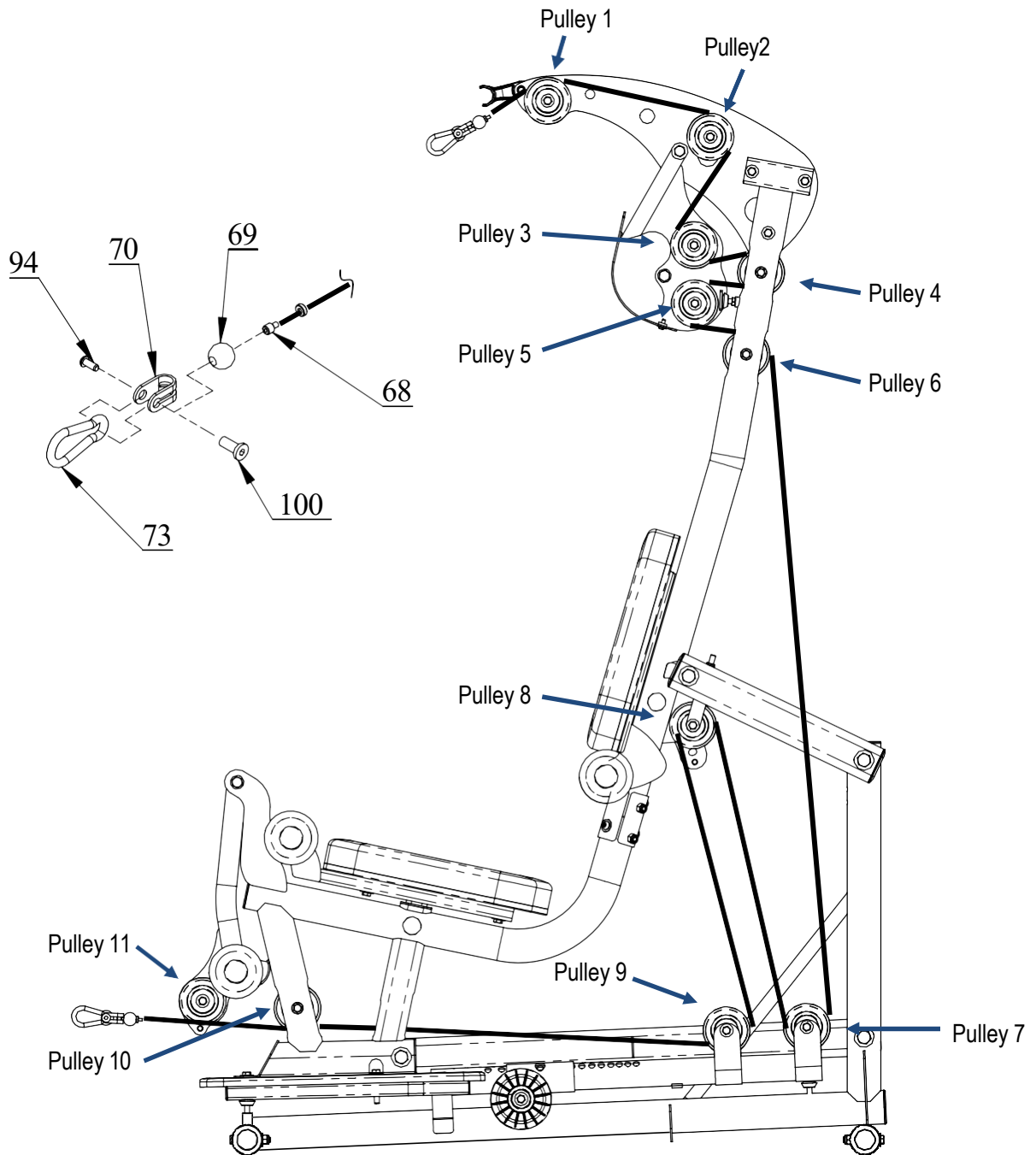

Began at the top of the machine and run the cable sequentially from pulley #1 to pulley #11, as shown in the above drawing. Once complete, finish both cable ends with a plastic ball (#69), "U" bracket (#70), flat head nut (#100), button head bolt (#94), and a spring clip (#73). Look back over the cable routing to make sure that the cable is sitting securely in each pulley.

**Note: Wrench tighten "U" bracket hardware at both ends of the cable.**

## STEP 16

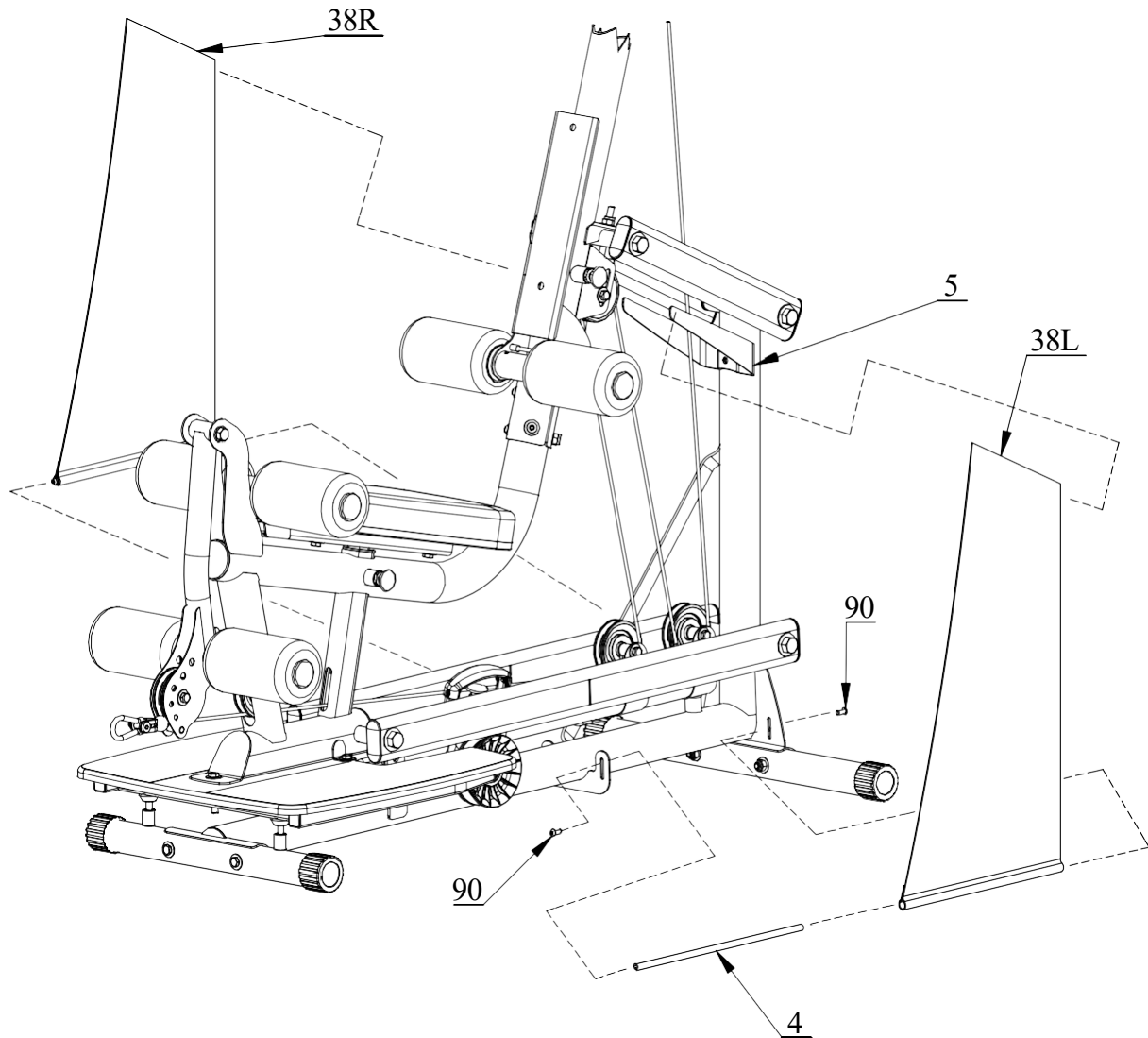

Attach Left and Right Shrouds (#38L & #38R) by first slipping the top of each Shroud onto the horns of the upper shroud mount (#5), as shown above. Make sure seams are to the inside. Next, slide rods (#4) into the bottom of each shroud and attach to frame using:

**Four M6\*12 Button Head Screws**

Note: Be sure to pull the shrouds down taut before tightening the four screws.

## STEP 17

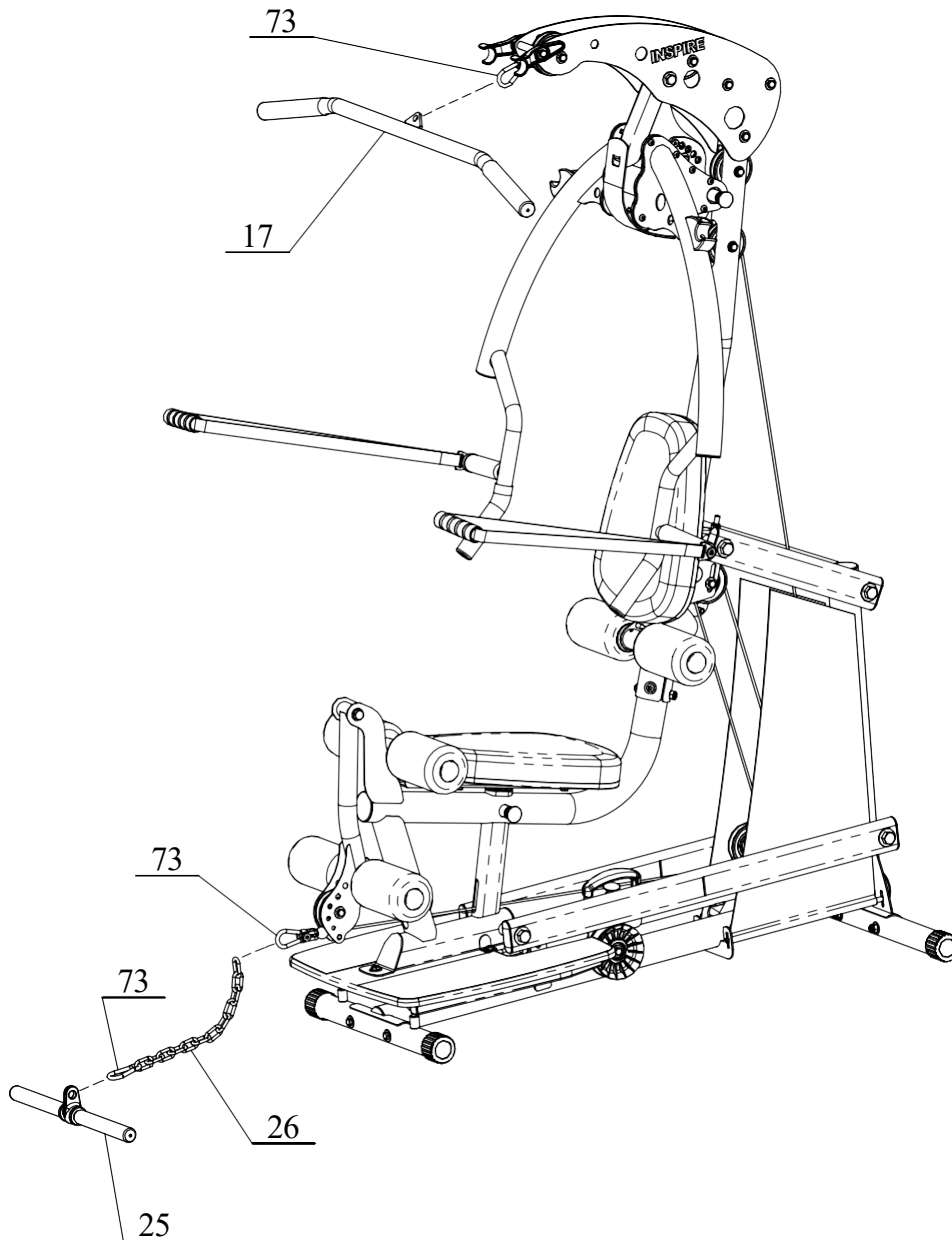

Attach Lat Bar (#17) to Spring Clip (#73).

Attach Chain (#26) to Spring Clip (#73) on the end of the Cable.

Attach Revolving Curl Bar (#25) to Chain (#26) with Spring Clip (#73).

## FINAL ADJUSTMENTS AFTER ASSEMBLY

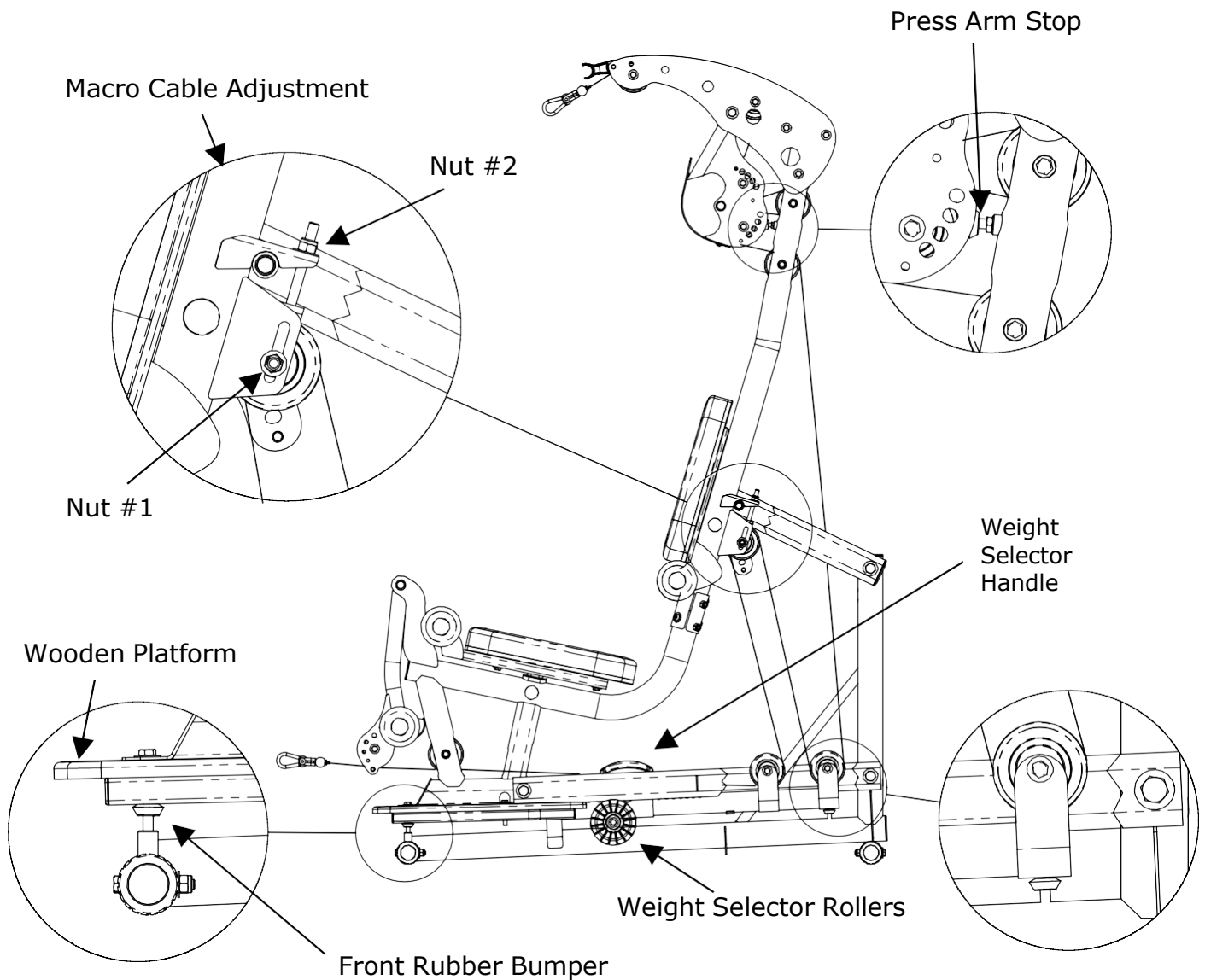

### **FINAL ADJUSTMENT:** (if needed)

Below the seat you will find the weight selector. Grab the weight selector handle and pull the spring loaded pin. Slide the weight selector from position one to fifteen. The rollers should move freely. If the weight selector rollers bind between positions 1-8, lift the wooden platform and adjust the two Front Rubber Bumpers up slightly. This will ease the pressure on the rollers and allow the weight selector mechanism to slide freely.

If the Weight Selector Rollers bind between positions 8-15, thread the press arm stop completely into the frame. This will provide slack in the cable and ease the pressure on the Weight Selector Rollers. If the Weight Selector Rollers are still binding, loosen nut #1 in the Macro Cable Adjustment drawing above. Next, adjust nut #2 counter clockwise until the Weight Selector Rollers move freely. Re-tighten nut #1.

### **NOTE:**

The cable on this gym will stretch over time. There are two places to eliminate cable slack. A large amount of cable slack can be removed by adjusting the pulley upward on the Macro Cable Adjustment. Start by loosening nut (#1) shown in the Macro Cable Adjustment drawing above. Next, using a wrench, turn nut (#2) clockwise until adequate cable slack has been removed. Finish by tightening nut #1 back up.

To eliminate a small amount of cable slack, adjust the Press Arm Stop counter clockwise. Wrench tighten Jam Nut.

# DECAL REFERENCE

<b>NOTICE</b>				
<i>This INSPIRE product is not intended for commercial use.</i>				
<i>IN HOME MAINTENANCE</i>	<i>Weekly</i>	<i>3 Months</i>	<i>Yearly</i>	<i>2 Years</i>
Inspect; Links, Pull Pins, Snap Locks, Swivels, Weight Stack Pins	✘			
Clean; Upholstery	✘			
Inspect; Cables and their fittings	✘			
Inspect tightness of all shrouds	✘			
Inspect; Accessory Bars and Handles		✘		
Inspect; All Decals		✘		
Inspect; All nuts and Bolts Tighten if Needed.		✘		
Inspect; Anti-Skid Surfaces		✘		
Clean & Lubricate; Guide Rods with a Teflon(PTFE) based lubricant (Superlube)		✘		
Lubricate; Seat Sleeves and all plastic slides		✘		
Clean & Wax; All Glossy Finishes			✘	
Replace; Cables, Belts and Connectin Parts.				✘



**INSPIRE™**  
 BY HEALTH IN MOTION LLC  
 877-738-1729  
[www.inspirefitness.net](http://www.inspirefitness.net)  
 Serial # 1-05-05-00001

This product is covered by one or more of the following U.S. Patents: 7,722,513; 7,837,600; 7,905,818; 5,330,405; 5,944,641; 5,961,427; and others pending



# DECAL REFERENCE

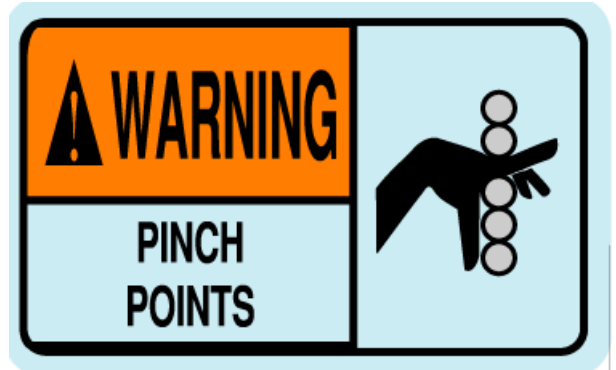

## ACCESSORIES

- Exercise Wall Chart
- Lat Bar
- Revolving Curl Bar

## HOME GYM OPTIONS

- D handles
- Aluminum EZ Curl Bar
- Ab Crunch Bar

## Training Tips

*CONSULT A PHYSICIAN BEFORE STARTING ANY EXERCISE PROGRAM*

1. **Always warm up** before you start weight training. This helps get your muscles warm and prevents injury. You can warm up with light cardio or by doing a light set of each exercise before going to heavier weights.
2. **Control the weight.** Always work with a weight that you can handle through a full range of motion. Slow and steady movements are recommended.
3. **Breathe.** Don't hold your breath during your set. Holding your breath builds internal pressure which increases your chance for broken blood vessels, as well as a hernia.
4. **Sit up straight.** Pay attention to your posture and keep everything straight. Engage your abs in every movement to keep balanced and protect your spine.

## **GENERAL MAINTENANCE INFORMATION**

- Periodically inspect the cables for splitting, cracking or fraying. Also, watch for bulging or flat areas in the cable.
- Immediately replace cables at the first signs of damage or wear. Never use equipment with damaged or worn cables.
- Cables naturally stretch over time, so check cable slack periodically and adjust cable tension as needed.
- Regularly inspect product for loose hardware.
- Do not use or store equipment outdoors.
- Inspect spring clips, swivels and handles for wear or damage. If wear or damage exists, replace immediately.
- Locate and familiarize yourself with all warning decals on the home gym.
- Replace damaged or worn upholstery immediately.

# MAINTENANCE SCHEDULE

ROUTINE	HOME MAINTENANCE	ENTRY DATE									
Inspect: Links, Pull Pins, Spring Clips, Swivels, Weight Stack Pins	WEEKLY										
Clean: Upholstery	WEEKLY										
Inspect: Cables and their Fittings	WEEKLY										
Inspect: Tautness of all Shrouds	WEEKLY										
Inspect: Accessory Bars and Handles	3 MONTHS										
Inspect: All Decals	3 MONTHS										
Inspect: All Nuts and Bolts. Tighten if Needed	3 MONTHS										
Inspect: Anti-Skid surfaces	3 MONTHS										
Clean and Lubricate: Guide Rods with a Teflon based lubricant	3 MONTHS										
Lubricate: Seat Sleeves and all Plastic Slides	3 MONTHS										
Clean and Wax: All Glossy Finishes	YEARLY										
Replace: Cables, Belts and Connecting Parts	2 YEARS										

# LIMITED WARRANTY

# INSPIRE

## **In-Home Lifetime Warranty.**

This Warranty applies only in the United States to Inspire strength products manufactured or distributed by Health In Motion LLC. The warranty period to the original purchaser is lifetime of the original purchaser.

Health In Motion warrants that the Product you have purchased for non-commercial, personal, family or household use from Health In Motion LLC or from an authorized Health In Motion reseller is free from defects in materials or workmanship under normal use during the warranty period. Your sales receipt, showing the date of purchase of the Product, is your proof of the date of purchase. This warranty extends only to you, the original purchaser. It is not transferable to anyone who subsequently purchases the Product from you. It excludes expendable parts such as paint and finish. This Warranty becomes VALID ONLY if the Product is assembled / installed according to the instructions / directions included with the Product.

## **Replacement and repair of parts.**

During the warranty period Health In Motion will at no additional charge, repair or replace the Product if it becomes defective, malfunctions, or otherwise fails to conform with this Warranty under normal non-commercial, personal, family, or household use. In repairing the product Health In Motion may replace defective parts with, at the option of Health In Motion, serviceable used parts that are equivalent to new parts in performance, or new parts. All exchanged parts and Products replaced under this warranty will become the property of Health In Motion. Health In Motion reserves the right to change manufacturers and or specification of any part to cover any existing warranty.

## **Service procedures.**

To obtain warranty parts, you must return the parts to Health In Motion or an authorized Health In Motion retailer in its original container (or equivalent). You must pre-pay any shipping charges, taxes, or any other charges associated with transportation of the Product. In addition, you are responsible for insuring any Product shipped or returned. You assume the risk of loss during shipment. You must present Health In Motion with proof-of-purchase documents (including the date of purchase, Model, and Serial Number). Any evidence of alteration, erasing or forgery of proof-of-purchase documents will be cause to void this Warranty.

## **Conditions and Exceptions.**

This Warranty does not extend to any Product not purchased from Health In Motion LLC or from an authorized Health In Motion reseller. This Warranty does not extend to any Product that has been damaged or rendered defective; (a) as a result of accident, misuse, or abuse; (b) by the use of parts not manufactured or sold by Health In Motion; (c) by modification of the Product; (d) as a result of service by anyone other than Health In Motion, or an authorized Health In Motion warranty service provider; (e) product that has not been properly maintained (follow maintenance schedule found on product). Should any product submitted for Warranty service be found to be ineligible, an estimate of repair cost will be furnished and the repair will be made if requested by you upon Health In Motion receipt of payment or acceptable arrangement of payment.

## **Disclaimer**

EXCEPT AS EXPRESSLY SET FORTH IN THIS WARRANTY HEALTH IN MOTION MAKES NO OTHER WARRANTIES; EXPRESSED OR IMPLIED INCLUDING ANY IMPLIED WARRANTIES OF MERCHANTABILITY AND FITNESS FOR A PARTICULAR PURPOSE. HEALTH IN MOTION EXPRESSLY DISCLAIMS ALL WARRANTIES NOT STATED IN THIS WARRANTY. ANY IMPLIED WARRANTIES THAT MAY BE IMPOSED BY LAW ARE LIMITED TO THE TERMS OF THIS WARRANTY. NEITHER HEALTH IN MOTION NOR ANY OF ITS AFFILIATES SHALL BE RESPONSIBLE FOR INCIDENTAL OR CONSEQUENTIAL DAMAGES. HEALTH IN MOTION IS NOT RESPONSIBLE FOR THE REPAIR OR REPLACEMENT OF ANY PARTS THAT HEALTH IN MOTION DETERMINES HAVE BEEN SUBJECTED AFTER THE DATE OF MANUFACTURE TO ALTERATION, NEGLIGENCE, ABUSE, MISUSE, NORMAL WEAR & TEAR, ACCIDENT, DAMAGE DURING TRANSIT OR INSTALLATION, FIRE, FLOOD, OR ANY ACT OF GOD. SOME STATES DO NOT ALLOW LIMITATIONS ON HOW LONG AN IMPLIED WARRANTY LASTS OR THE EXCLUSION OR LIMITATION OF INCIDENTAL OR CONSEQUENTIAL DAMAGES, SO THE ABOVE LIMITATIONS OR EXCLUSION MAY NOT APPLY TO YOU. This Warranty gives you specific legal rights and you may also have other rights that may vary from state to state. This is the only express warranty applicable to Health In Motion's "Inspire" branded strength products. Health In Motion neither assumes nor authorizes anyone to assume for it any other express warranty.