

INSPIRE

ASSEMBLY & OPERATION MANUAL

FT-1 BENCH (FIDB)

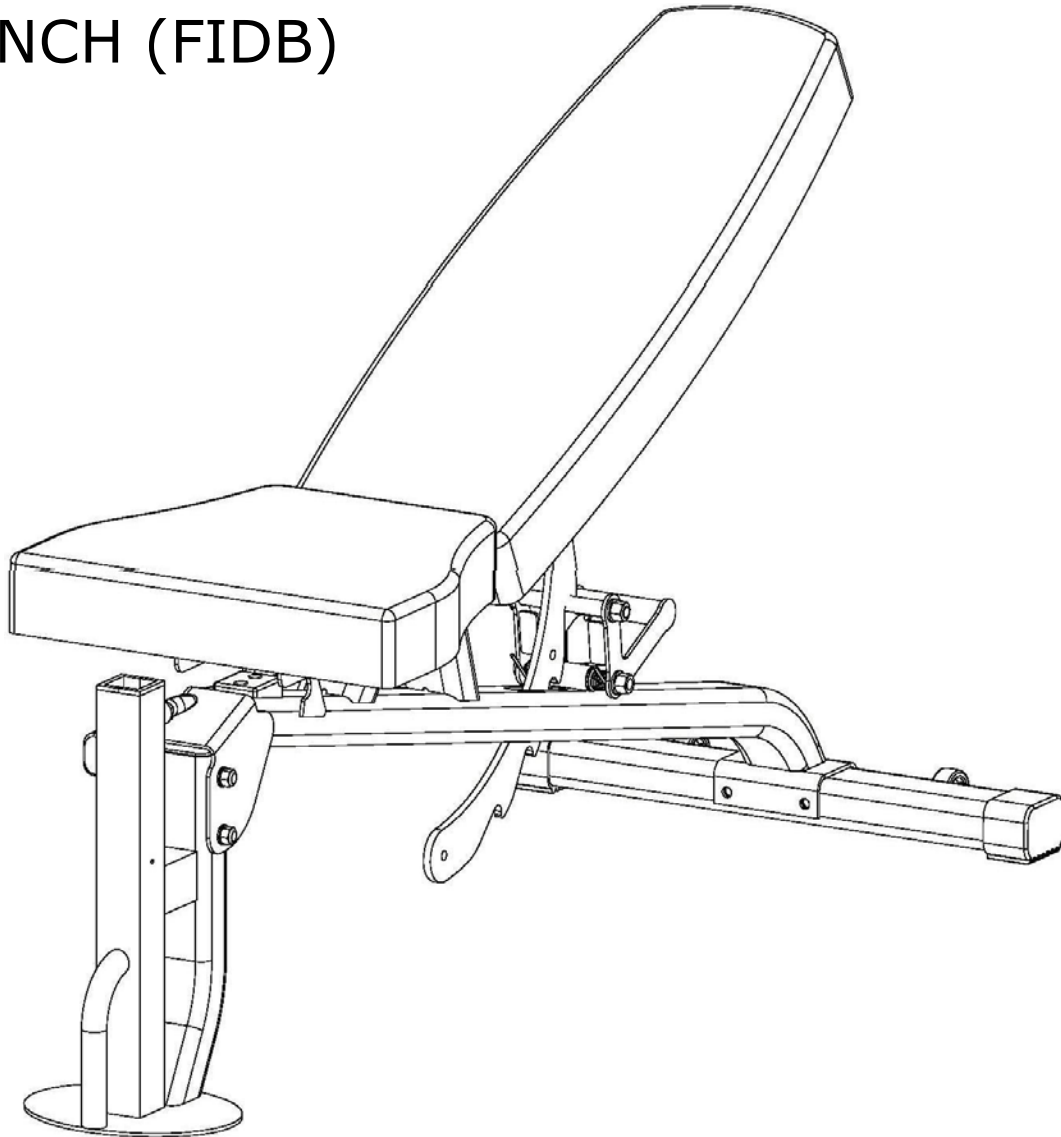

RECORD SERIAL NUMBER HERE

TABLE OF CONTENTS

Section Description	Page
Before You Begin.....	1
Important Safety Notices.....	2
Tools Required.....	2
Parts List.....	3
Hardware and Tool List.....	4
Assembly Instructions.....	5-8
Exploded Diagram.....	9
General Maintenance Information.....	10
Limited Warranty.....	11

BEFORE YOU BEGIN

Read this entire manual before attempting to build or use your bench. This manual contains step by step instructions for proper assembly.

Use the parts list included in this manual to verify that all parts are accounted for before assembly. If any parts are missing, contact the retailer of this home gym for replacement parts. Or, call Inspire at 877-738-1729

Service of your home gym should only be preformed by an authorized INSPIRE retailer. Service preformed by anyone else can result in loss of warranty. Use only Inspire replacement parts on this machine. The use of any other brand of parts can also result in a loss of warranty. If you need help finding an authorized retailer, please contact us directly:

Inspire Fitness
4945 East Hunter Ave.
Anaheim, CA 92807
Ph: 877-738-1729
Fx: 714-738-1728
www.inspirefitness.net

IMPORTANT SAFETY NOTICE

PRECAUTIONS

This exercise bench is built for optimum safety. However, certain precautions apply whenever you use a piece of exercise equipment. Be sure to read the entire manual before you assemble or use your bench. In particular, note the following safety precautions:

1. Keep children and pets away from the bench at all times. .
2. Only one person at a time should use the bench.
3. If the user experiences dizziness, nausea, chest pain, or any other abnormal symptoms, STOP the workout at once. Consult a Physician.
4. Position the bench on a clear, leveled surface. Do not use outdoors.
5. Keep hands away from all moving parts.
6. Always wear appropriate workout clothing when exercising. Running or aerobic shoes are also required when using the bench.
7. Use the bench only for its intended use as described in this manual.
8. Disabled persons should not use this bench without a qualified person or physician in attendance.
9. Always do stretching exercises to properly warm up before using this bench.
10. Never use this bench if it is not functioning properly.
11. A spotter is recommended during exercise.
12. Maximum user weight on bench is 300 lbs.

TOOLS REQUIRED FOR ASSEMBLY

Tools required for assembling the bench: Adjustable Wrench and Allen Wrenches.

PARTS LIST

Part#	Description	Q'ty (pcs)
2	Ø 3/4" Washer	8
3	Ø 5/8" Washer	6
4	Front Post Assembly	1
5	Main Seat Support Assembly	1
6	Rear Stabilizer	1
8	Backrest Board	1
9	Seat Pad	1
11	M10 Aircraft Nut	4

Hardware and Tool List

Note: The following parts are not drawn to scale. Please use your own ruler or scale to measure sizes.



#2 \varnothing $\frac{3}{4}$ " Washer (Qty8)



#3 \varnothing $\frac{5}{8}$ " Washer (Qty6)



#11 M10 Aircraft Nut (Qty4)



#1 M10 x 3 $\frac{3}{4}$ " Allen Bolt (Qty4)



#10 M8 x 2 $\frac{3}{4}$ " Allen Bolt (Qty2)



#7 M8 x 1" Allen Bolt (Qty4)

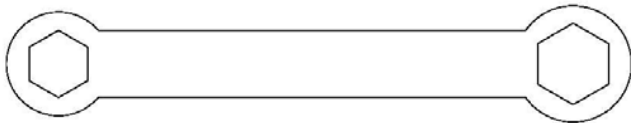

#56 TOOL: #17 Crossing Wrench (Qty 1)



#53 TOOL: #6 Allen Wrench (Qty 1)



#54 TOOL: #5 Allen Wrench (Qty 1)

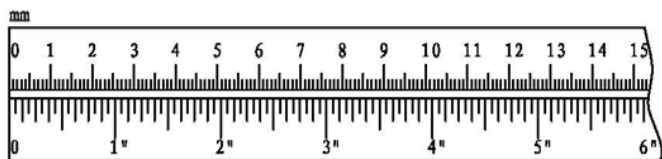

BENCH ASSEMBLY INSTRUCTIONS

STEP 1

- A.) Attach the Main Seat Support (#5) onto the Front Post (#4).
- B.) Secure it with two M10 x 3 3/4" Allen Bolts (#1), four Ø 3/4" Washers (#2), and two M10 Aircraft Nuts (#11).
- C.) Do not tighten the Nuts and Bolts yet.

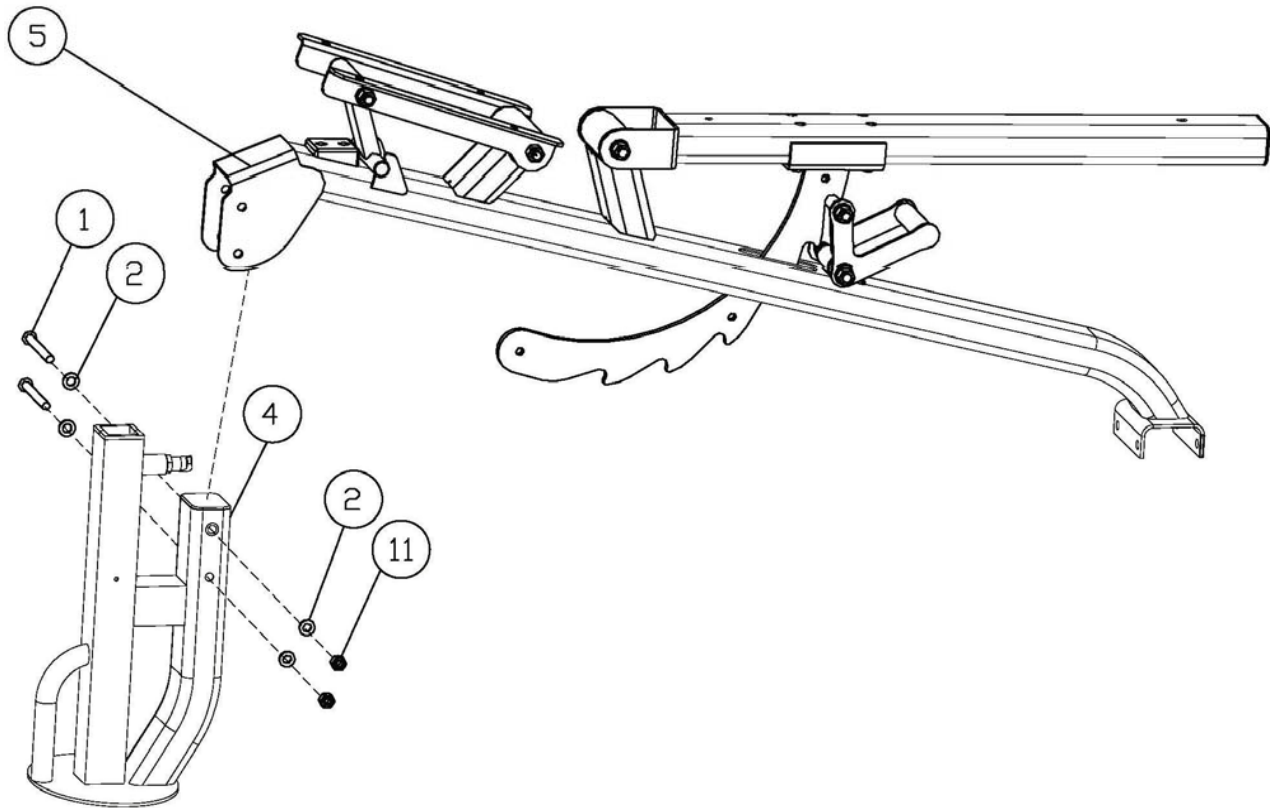

STEP 2

- A.) Attach the Main Seat Support (#5) onto the Rear Stabilizer (#6) **make sure Warning Sticker is facing up.**
- B.) Secure it with two M10 x 3 3/4" Allen Bolts (#1), four Ø 3/4" Washers (#2), and two M10 Aircraft Nuts (#11).
- C.) Securely tighten all Nuts and Bolts installed.

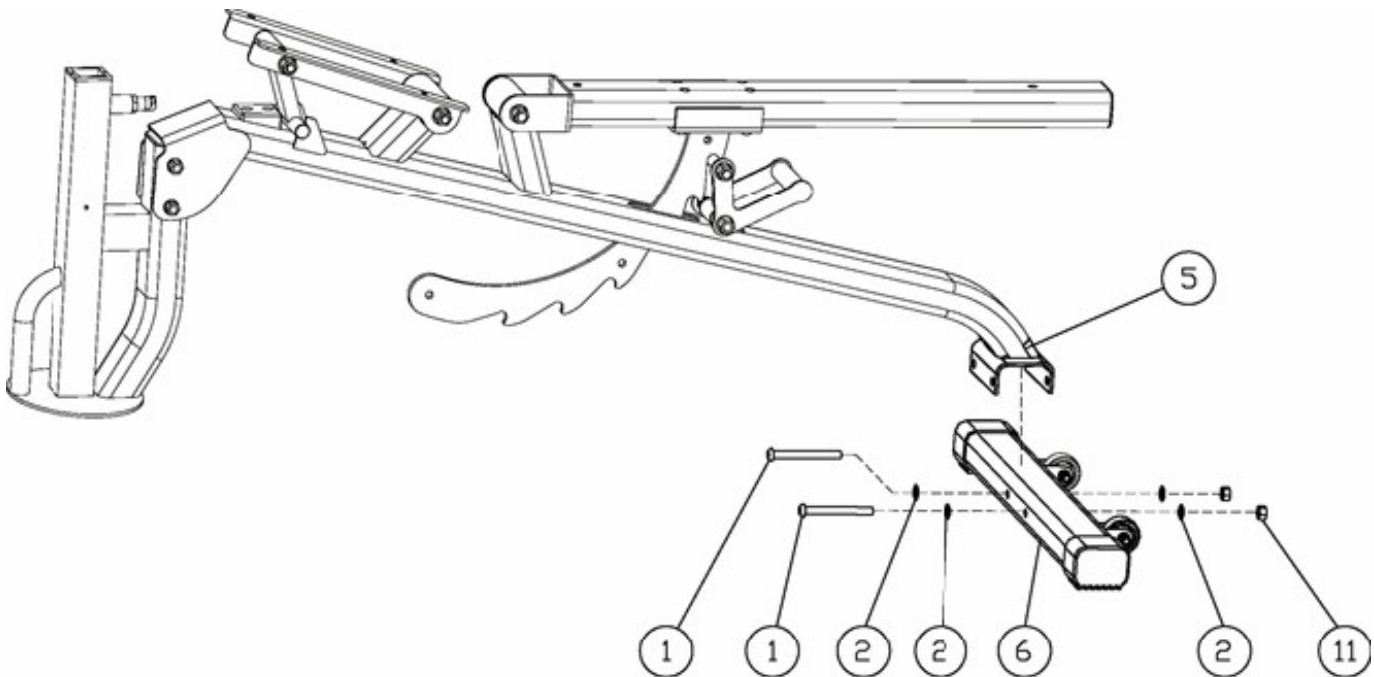

STEP 3

- A.) Place the Seat Pad (#9) onto the Main Seat Support Assembly (#5).
- B.) Secure it with four M8 x 1" Allen Bolts (#7) and $\text{\O} 5/8"$ Washers (#3).

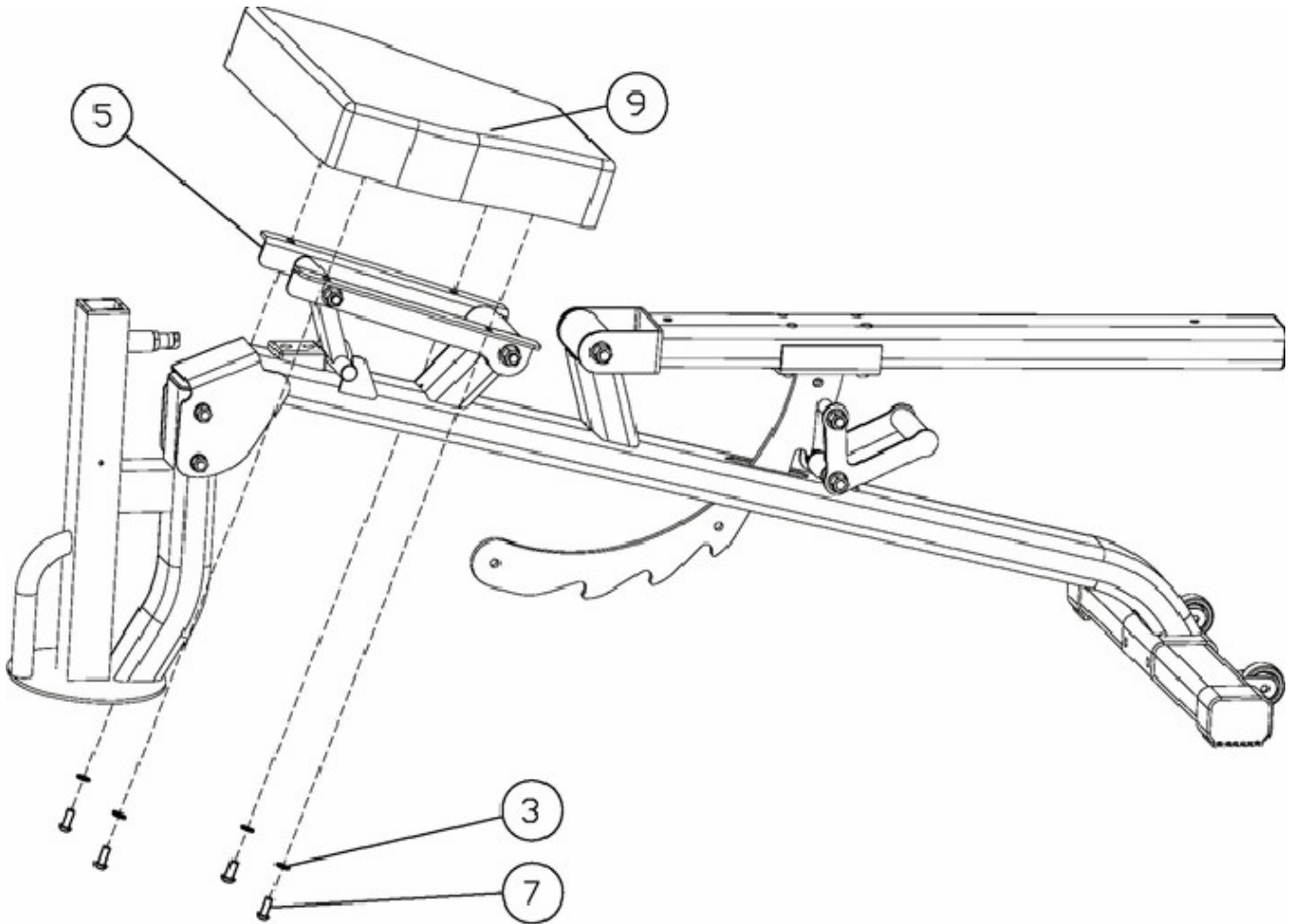

STEP 4

- A.) Attach the Backrest Board (#8) to the Main Seat Support Assembly (#5).
- B.) Secure it with two M8 x 2 3/4" Allen Bolts (#10) and Ø 5/8" Washers (#3).
- C.) When adjusting the Backrest Board to an incline position, simply pull up the board. When adjusting the Board to decline or flat positions, press or step down on the Backrest Adjustment Lever to disengage the Lever to allow the Board to go down.

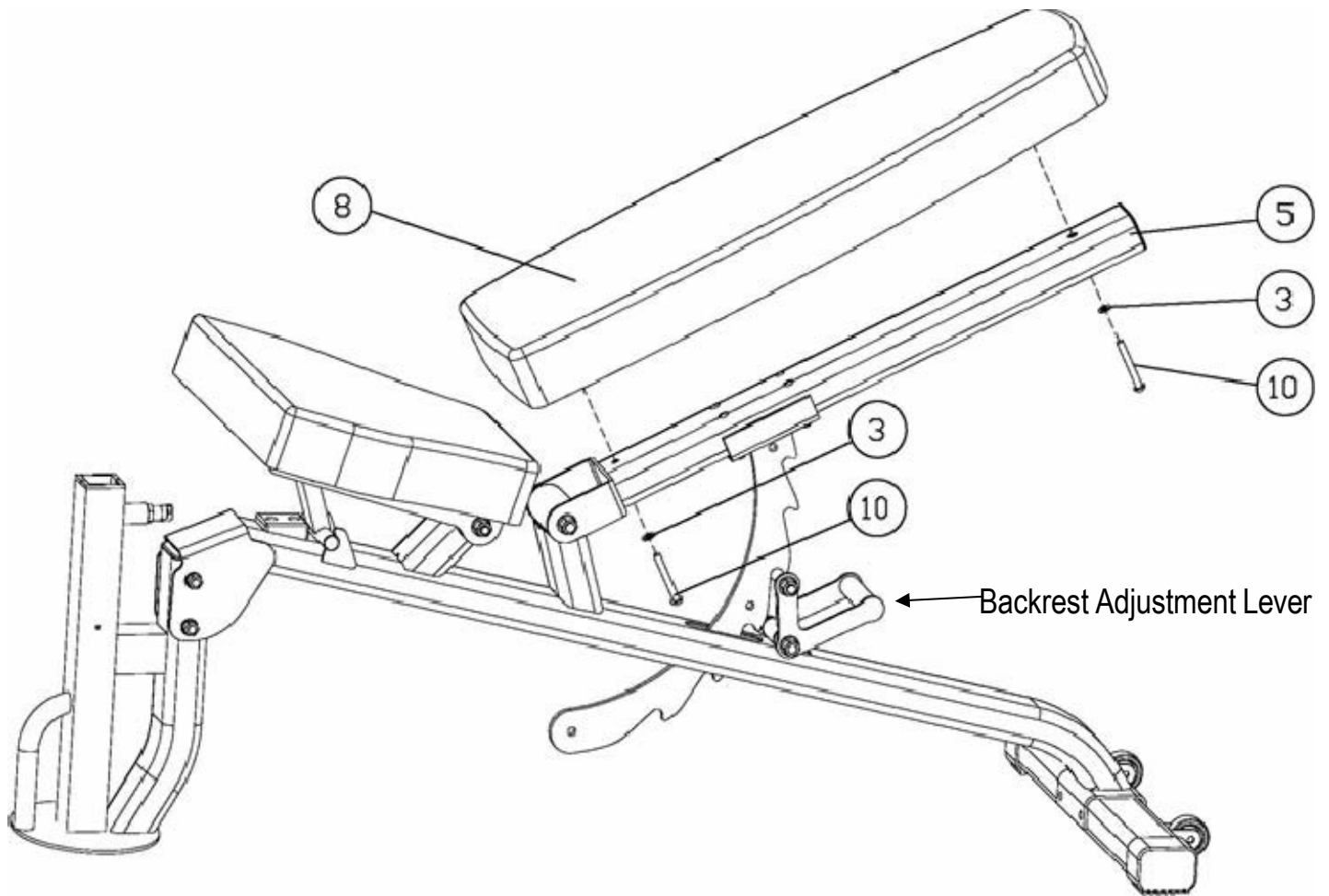

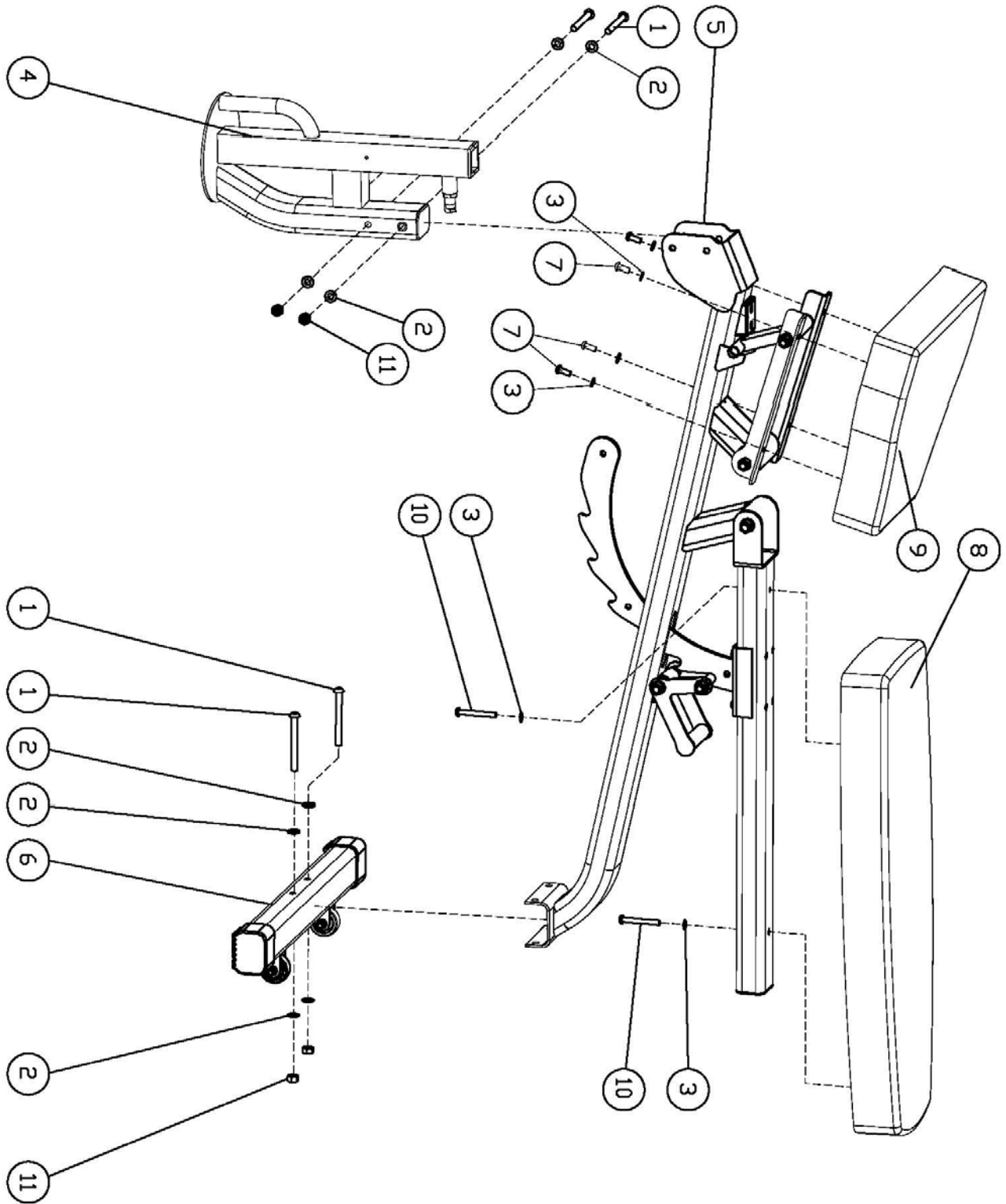

EXPLODED DIAGRAM

GENERAL MAINTENANCE INFORMATION

- Regularly inspect product for loose hardware.
- Do not use or store equipment outdoors.
- Locate and familiarize yourself with all warning decals on the home gym.
- Replace damaged or worn upholstery immediately.

LIMITED WARRANTY

INSPIRE

In-Home Lifetime Warranty.

This Warranty applies only in the United States to Inspire strength products manufactured or distributed by Health In Motion LLC. The warranty period to the original purchaser is lifetime of the original purchaser.

Health In Motion warrants that the Product you have purchased for non-commercial, personal, family or household use from Health In Motion LLC or from an authorized Health In Motion reseller is free from defects in materials or workmanship under normal use during the warranty period. Your sales receipt, showing the date of purchase of the Product, is your proof of the date of purchase. This warranty extends only to you, the original purchaser. It is not transferable to anyone who subsequently purchases the Product from you. It excludes expendable parts such as paint and finish. This Warranty becomes VALID ONLY if the Product is assembled / installed according to the instructions / directions included with the Product.

Replacement and repair of parts.

During the warranty period Health In Motion will at no additional charge, repair or replace the Product if it becomes defective, malfunctions, or otherwise fails to conform with this Warranty under normal non-commercial, personal, family, or household use. In repairing the product Health In Motion may replace defective parts with, at the option of Health In Motion, serviceable used parts that are equivalent to new parts in performance, or new parts. All exchanged parts and Products replaced under this warranty will become the property of Health In Motion. Health In Motion reserves the right to change manufacturers and or specification of any part to cover any existing warranty.

Service procedures.

To obtain warranty parts, you must return the parts to Health In Motion or an authorized Health In Motion retailer in its original container (or equivalent). You must pre-pay any shipping charges, taxes, or any other charges associated with transportation of the Product. In addition, you are responsible for insuring any Product shipped or returned. You assume the risk of loss during shipment. You must present Health In Motion with proof-of-purchase documents (including the date of purchase, Model, and Serial Number). Any evidence of alteration, erasing or forgery of proof-of-purchase documents will be cause to void this Warranty.

Conditions and Exceptions.

This Warranty does not extend to any Product not purchased from Health In Motion LLC or from an authorized Health In Motion reseller. This Warranty does not extend to any Product that has been damaged or rendered defective; (a) as a result of accident, misuse, or abuse; (b) by the use of parts not manufactured or sold by Health In Motion; (c) by modification of the Product; (d) as a result of service by anyone other than Health In Motion, or an authorized Health In Motion warranty service provider; (e) product that has not been properly maintained (follow maintenance schedule found on product). Should any product submitted for Warranty service be found to be ineligible, an estimate of repair cost will be furnished and the repair will be made if requested by you upon Health In Motion receipt of payment or acceptable arrangement of payment.

Disclaimer

EXCEPT AS EXPRESSLY SET FORTH IN THIS WARRANTY HEALTH IN MOTION MAKES NO OTHER WARRANTIES; EXPRESSED OR IMPLIED INCLUDING ANY IMPLIED WARRANTIES OF MERCHANTABILITY AND FITNESS FOR A PARTICULAR PURPOSE. HEALTH IN MOTION EXPRESSLY DISCLAIMS ALL WARRANTIES NOT STATED IN THIS WARRANTY. ANY IMPLIED WARRANTIES THAT MAY BE IMPOSED BY LAW ARE LIMITED TO THE TERMS OF THIS WARRANTY. NEITHER HEALTH IN MOTION NOR ANY OF ITS AFFILIATES SHALL BE RESPONSIBLE FOR INCIDENTAL OR CONSEQUENTIAL DAMAGES. HEALTH IN MOTION IS NOT RESPONSIBLE FOR THE REPAIR OR REPLACEMENT OF ANY PARTS THAT HEALTH IN MOTION DETERMINES HAVE BEEN SUBJECTED AFTER THE DATE OF MANUFACTURE TO ALTERATION, NEGLIGENCE, ABUSE, MISUSE, NORMAL WEAR & TEAR, ACCIDENT, DAMAGE DURING TRANSIT OR INSTALLATION, FIRE, FLOOD, OR ANY ACT OF GOD. SOME STATES DO NOT ALLOW LIMITATIONS ON HOW LONG AN IMPLIED WARRANTY LASTS OR THE EXCLUSION OR LIMITATION OF INCIDENTAL OR CONSEQUENTIAL DAMAGES, SO THE ABOVE LIMITATIONS OR EXCLUSION MAY NOT APPLY TO YOU. This Warranty gives you specific legal rights and you may also have other rights that may vary from state to state. This is the only express warranty applicable to Health In Motion's "Inspire" branded strength products. Health In Motion neither assumes nor authorizes anyone to assume for it any other express warranty.