

INSPIRE FT1

ASSEMBLY & OPERATION MANUAL

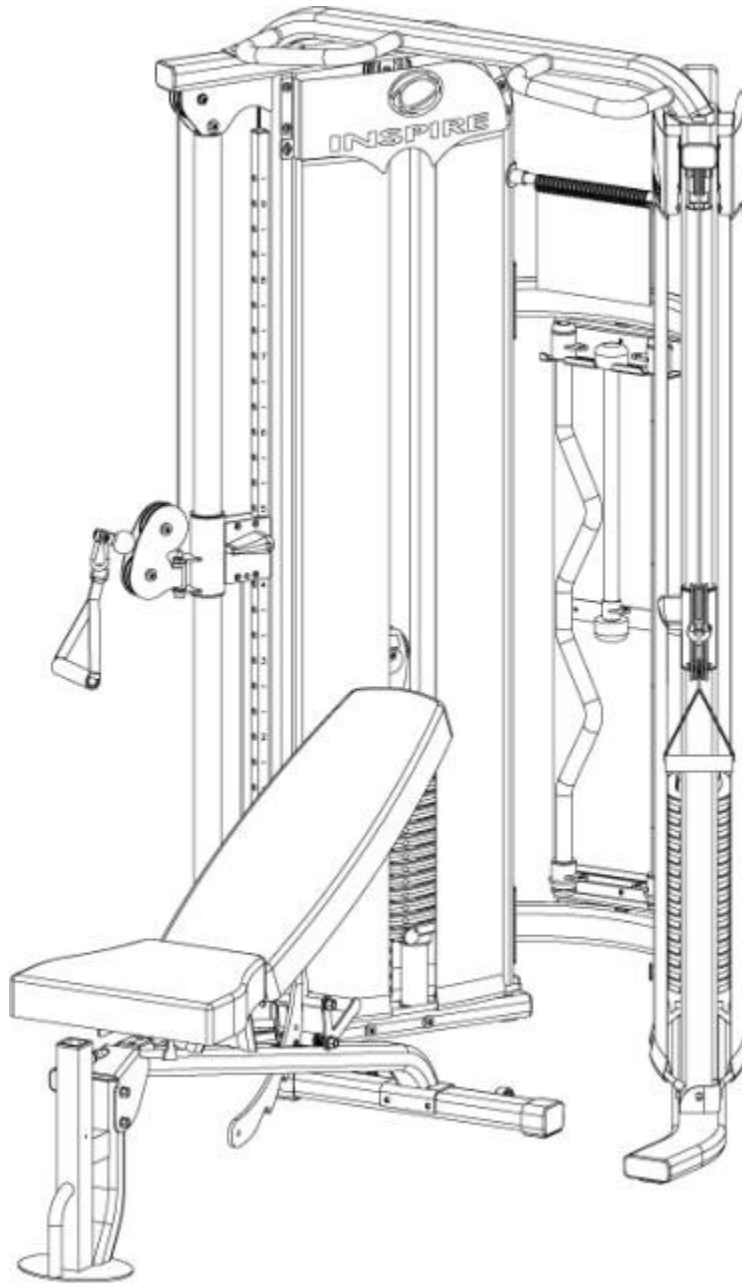

RECORD SERIAL NUMBER HERE

TABLE OF CONTENTS

◆ Section Description	Page
◆ Before You Begin.....	1
◆ Important Safety Notices.....	2
◆ Tools Requires	2
◆ Parts List.....	3
◆ Hardware Sizing Chart	4
◆ Assembly Instructions.....	5-16
◆ Exploded Diagram	17
◆ General Maintenance Information.....	18
◆ Maintenance Schedule.....	19
◆ Limited Warranty	20

BEFORE YOU BEGIN

Read this entire manual before attempting to build or use your gym. This manual contains step by step instructions for proper assembly.

Use the parts list included in this manual to verify that all parts are accounted for before assembly. If any parts are missing, contact the retailer of this home gym for replacement parts. Or, call Inspire at 714-738-1729

Service of your home gym should only be preformed by an authorized INSPIRE retailer. Service preformed by anyone else can result in loss of warranty. Use only Inspire replacement parts on this machine. The use of any other brand of parts can also result in a loss of warranty. If you need help finding an authorized retailer, please contact us directly:

Inspire Fitness
4945 East Hunter Ave.
Anaheim, CA 92807
Ph: 877-738-1729
Fx: 714-738-1728
www.inspirefitness.net

IMPORTANT SAFETY NOTICE

PRECAUTIONS

This exercise machine is built for optimum safety. However, certain precautions apply whenever you operate a piece of exercise equipment. Be sure to read the entire manual before you assemble or operate your machine. In particular, note the following safety precautions:

1. Keep children and pets away from the machine at all times. DO NOT leave children unattended in the same room with the machine.
2. Only one person at a time should use the machine.
3. If the user experiences dizziness, nausea, chest pain, or any other abnormal symptoms, STOP the workout at once. Consult a Physician.
4. Position the machine on a clear, leveled surface. Do not use outdoors.
5. Keep hands away from all moving parts.
6. Always wear appropriate workout clothing when exercising. Running or aerobic shoes are also required when using the machine.
7. Use the machine only for its intended use as described in this manual.
8. Disabled persons should not use the machine without a qualified person or physician in attendance.
9. Always do stretching exercises to properly warm up before using machine.
10. Never operate the machine if it is not functioning properly.
11. A spotter is recommended during exercise.
12. Maximum user weight on bench is 300 lbs.

TOOLS REQUIRED FOR ASSEMBLY

Tools Required for Assembling the Machine: Adjustable Wrench and Allen Wrenches. NOTE: Two or more people assembling this machine is a must. DO NOT attempt to assemble this machine alone.

PARTS LIST

Part#	Description	Qty (pcs)	Part#	Description	Qty (pcs)
1	Right Station Assembly	1	33	Left Inner Logo Plate	1
2	Left Station Assembly	1	34	Shroud Mount Bar	4
3	Upper Frame Assembly	1	35	Hanger Panel	1
4	Lower Cross Brace	1	36	Height Adjustment Handle	2
5	Upper Cross Brace	1	37	Rubber Bumper	4
6	Guide Rod Bracket&Ring Cap	2	38	Plastic Washer	2
7	Guide Rod	4	39	Hook	2
8	Exercise Chart Hanger Bracket	2	40	M6 x 5/8" Allen Bolt	16
9	Exercise Chart Hanger	1	41	M10 x 3 1/8" Allen Bolt	4
10	Selector Stem Assembly	2	42	M10 x 2 3/4" Allen Bolt	8
11	Support Frame for Weight Stack	4	43	M10 x 1" Allen Bolt	4
12	Weight Selector Pin	2	44	M10 x 3/4" Allen Bolt	4
13	Weight Plate	30	45	M5 x 3/8" Allen Bolt	2
14	Upper Hanger Bracket	1	46	M8 x 1/2" Allen Bolt	1
15	Lower Hanger Bracket	1	47	Ø 3/4" Lock Washer	8
16	Upper Hanger	1	48	M10 Aircraft Nut	8
17	Middle Hanger	1	49	Ø 7/8" Washer	21
18	Lower Hanger	1	50	Ø 1" Washer	28
19	Middle Hanger Bracket	1	51	Ø 3/4" Washer	12
20	Rope	1	52	D-shaped Washer	1
21	Sports Handle	1	53	#6 Allen Wrench (Tool)	1
22	Curl Bar	1	54	#5 Allen Wrench (Tool)	1
23	Straight Bar	1	55	#4 Allen Wrench (Tool)	1
24	Single Handle	2	56	#17 Crossing Wrench (Tool)	1
25	Chin Up Belt	1	57	Flip Exercise Chart	1
26	Ankle Strap	1	58	Resistance Label Set	2
27	Outer Fabric Shroud	2	59	M8 x 5/8" Allen Bolt	20
28	Inner Fabric Shroud	4	60	Ø 2" Tension Adjustment Plate	2
29	Lower Shroud Mount	4	61	Pulley	2
30	Left Outer Logo Plate	1	62	U-shaped Pulley Bracket	2
31	Right Outer Logo Plate	1	63	5LBS Weight Block	2
32	Right Inner Logo Plate	1			

HARDWARE SIZING CHART



#50 Ø 1" Washer (Qty 28)



#51 Ø 3/4" Washer (Qty 12)



#49 Ø 7/8" Washer (Qty 21)



#52 D-shaped Washer (Qty 1)



#42 M10 x 2 3/4" Allen Bolt (Qty 8)



#43 M10 x 1" Allen Bolt (Qty 4)



#40 M6 x 5/8" Allen Bolt (Qty 16)



#45 M5 x 3/8" Allen Bolt (Qty 2)



#46 M8 x 1/2" Allen Bolt (Qty 1)



#59 M8 x 5/8" Allen Bolt (Qty 20)



#48 M10 Aircraft Nut (Qty 8)



#47 3/4" Lock Washer (Qty 4)



#38 Plastic Washer (Qty 2)

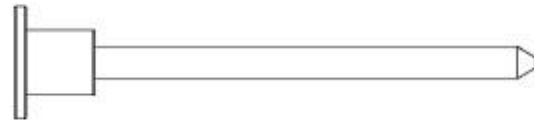

#12 Weight Selector Pin (Qty 2)



#56 TOOL: #17 Crossing Wrench (Qty 1)



#55 TOOL: #4 Allen Wrench (Qty 1)



#54 TOOL: #5 Allen Wrench (Qty 1)



#53 TOOL: #6 Allen Wrench (Qty 1)

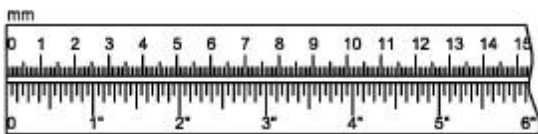

FUNCTIONAL TRAINER ASSEMBLY INSTRUCTIONS

STEP 1 (See Diagram 1)

A.) Do not tighten the Nuts and Bolts until instructed to do so.

B.) Place the Lower Cross Brace (#4) between the Right & Left Stations (#1 & #2) in the mid-span.

C.) Attach one end of the Lower Cross Brace to the Right Station. Secure it with two M10 x 2 ¾ " Allen Bolts (#42), four Ø 1" Washers (#50), and two M10 Aircraft Nuts (#48). Repeat the same procedure to install the other side.

D.) Repeat Procedure B & C to install the Upper Cross Brace (#5).

E.) Place the Upper Frame (#3) on top of the Right and Left Stations.

F.) Secure each end with two M10 x 1" Allen Bolts (#43), two Ø ¾ " Lock Washers (#47), and

Ø 1" Washers (#50). G.) Securely tighten all Nuts and Bolts installed

Diagram 1

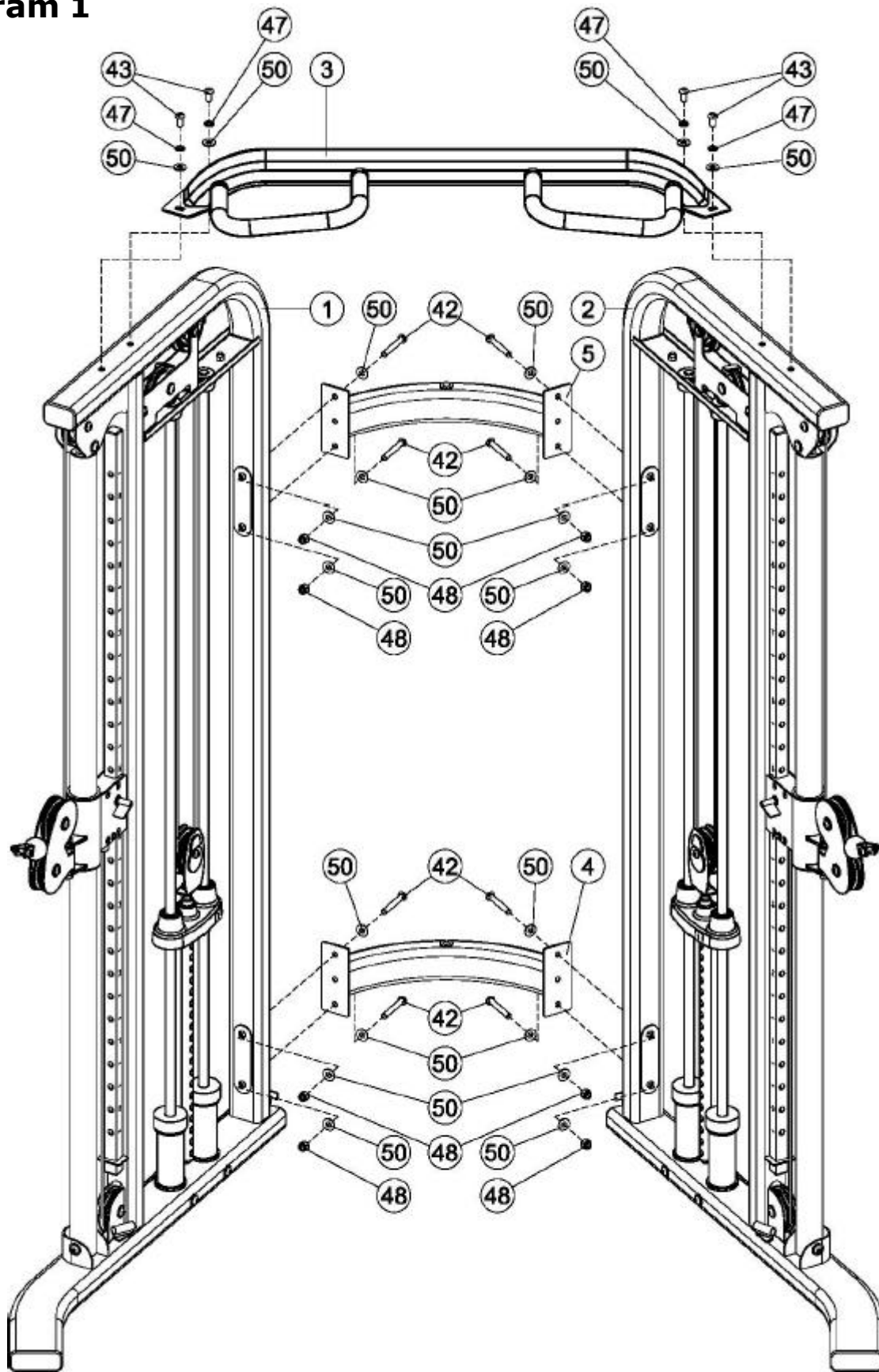

STEP 2 (See Diagram 2)

- A.) Lift up the Selector Stem (#10) on the Right Station (#1) and hold it still to release the tension on the cables. Remove the two M10 x 3/4 " Allen Bolts (#44), Ø 3/4 " Spring Washers (#47), and Ø 1" Washers (#50) which were pre-assembled in the factory to hold the Guide Rod Bracket (#6).**
- B.) Pull the two Guide Rods (#7) away from the Upright. Remove the Guide Rod Bracket (#6) from the top of the Guide Rods.**
- C.) Remove the Selector Stem (#19) from the Guide Rods.**
- D.) Slide fifteen 10lb Weight Plates (#13) from the top of Guide Rods down to the Rubber Bumpers (#37). Make sure the weight sticker cut out is facing the inside of the machine.**
- E.) Slide the Selector Stem back onto the Guide Rods. Hold the Selector Stem above the weight stack to make it easier to re-install Guide Rods and Bracket.**
- F.) Re-install the Guide Rod Bracket (#6) onto the Guide Rods.**
- G.) Push the Guide Rod Bracket back into the upright.**
- H.) Secure the Bracket back to the upright frame with the two M10 x 3/4 " Allen Bolts (#44), Ø 3/4 " Spring Washers (#47), Ø 1" Washers (#50).**
- I.) Lower the Selector Stem down onto the top of the weight stack.**
- J.) Check all the cables to make sure they are on track on the pulleys.**
- K.) Peel off the weight resistance label from the Resistance Label Set (#58) and attach to the plates.**
- L.) Insert the Weight Selector Pin (#12) into the weight stack.**
- M.) Lubricate the Guide Rods with super lube or lube provided.**
- N.) If Needed, Adjust the Cable tension by first loosening the M10 x 2" Allen Bolt (#10) then rotate the Tension Adjustment Plate (#60) clock or counterclockwise to move the Bolt and the Large Pulley (#61) up and down along the open track inside the U-shaped Pulley Bracket (#62). Once desired tension is achieved, securely tighten the Bolt (#10) back.**
- O.) Repeat the Procedure A through N above to install the other set of weight plates to the Left Station (#2).**

Diagram 2

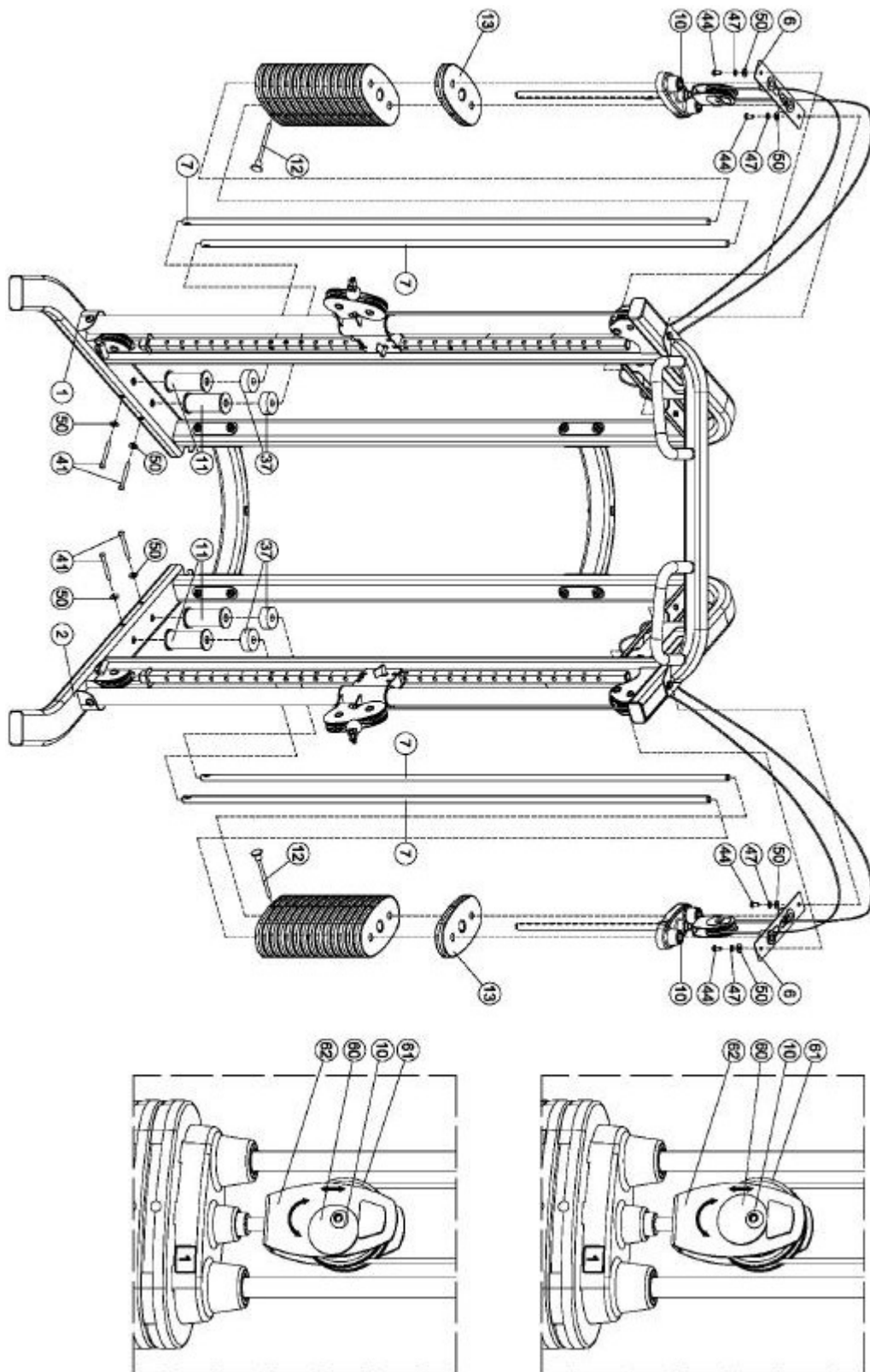

STEP 3 (See Diagram 3)

- A.) Slide a Plastic Washer (#38) onto the axle on Upper Hanger Bracket (#14). Insert the axle through the Upper Cross Brace (#5) from bottom. Secure it with one M8 x 1/2 " Allen Bolt (#46), one Ø 7/8" Washer (#49), and one D-shaped Washer (#52).**
- B.) Slide a Plastic Washer (#38) onto the axle on Lower Hanger Bracket (#15). Insert the axle into the Lower Cross Brace (#4) from top.**
- C.) Do not tighten the Bolts until instructed to do so.**
- D.) Attach the Hanger Panel (#35) to the Upper Hanger Bracket. Attach the Upper Hanger (#16) to the Hanger Panel. Align the holes. Secure them together with three M6 x 5/8" Allen Bolts (#40) and Ø 3/4 " Washer (#47).**
- E.) Repeat Procedure D to install the Lower Hanger (#18).**
- F.) Attach the Middle Hanger Bracket (#19) and the Middle Hanger (#17) to the Hanger Panel from each side. Align the holes. Secure them together with two M6 x 5/8" Allen Bolts (#40) and Ø 3/4 " Washer (#51).**
- G.) Securely tighten all the Bolts.**

Diagram 3

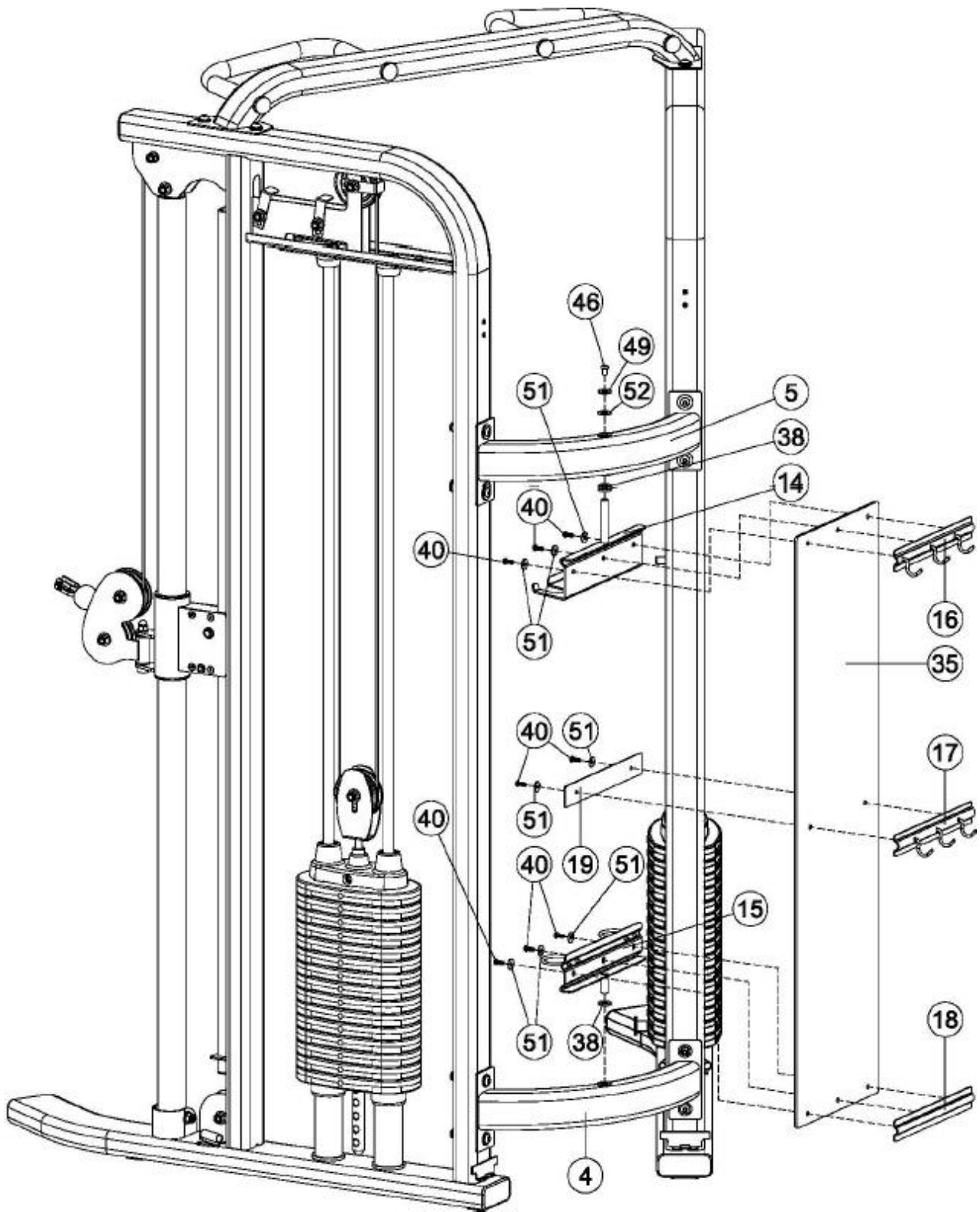

STEP 4 (See Diagram 4) (Attach Shrouds)

Start on the Right Side of the gym.

A.) Slide two panels of the Inner Fabric Shroud (#28) onto a Shroud Mount Bar (#34) so the seams face inside. Attach the Shroud Mount Bar (#34) to the inside upper frame as shown, using two **M8x5/8"** Allen Bolts (#59) and two **Ø 7/8"** Washers (#49). **Please Note:** The ends of the Shroud Mount Bar are slotted. Be sure to position the bolts in the center of both slots and tighten completely.

B.) Slide a Lower Shroud Mount (#29) through the bottom loops of the two Inner Fabric Shroud panels (#28) in Step A. Attach the Lower Shroud Mount (#29) to the gym frame by sliding one end into the frame insert. The other end latches under the notched flange and attaches with one **M6X5/8"** Allen Bolt (#40).

C.) Attach the Right Inner Logo Plate (#32) as shown using three **M8x5/8"** Allen Bolts (#59) and three **Ø 7/8"** Washers (#49)

D.) Slide the Outer Fabric Shroud (#27) onto a Shroud Mount Bar so the seams face inside.

(#34) Attach the Shroud Mount Bar (#34) to the outside upper frame as shown, using two **M8x5/8"** Allen Bolts. (#59) and two **Ø 7/8"** Washers (#49). **Please Note:** The ends of the Shroud Mount Bar are slotted. Be sure to position the bolts in the center of both slots and tighten completely.

E.) Slide a Lower Shroud Mount (#29) through the bottom loop of the Outer Fabric Shroud (#27) in Step D. Attach the Lower Shroud Mount (#29) to the gym frame by sliding one end into the frame insert. The other end latches under the notched flange and attaches with one **M6X5/8"** Allen Bolt (#40).

F.) Repeat steps A through E to install shrouds to the Left Side of the gym.

Note: To loosen or tighten the shrouds release the Lower Shroud Mount (#29) from the gym. Next loosen the two bolts in the Shroud Mount Bar (#34). Adjust the Shroud Mount Bar (#34) up to tighten or down to loosen. Once desired position is found, tighten the bolts that secure the Shroud Mount Bar (#34). Then reattach the Lower Shroud Mount by following step B.

Diagram 4

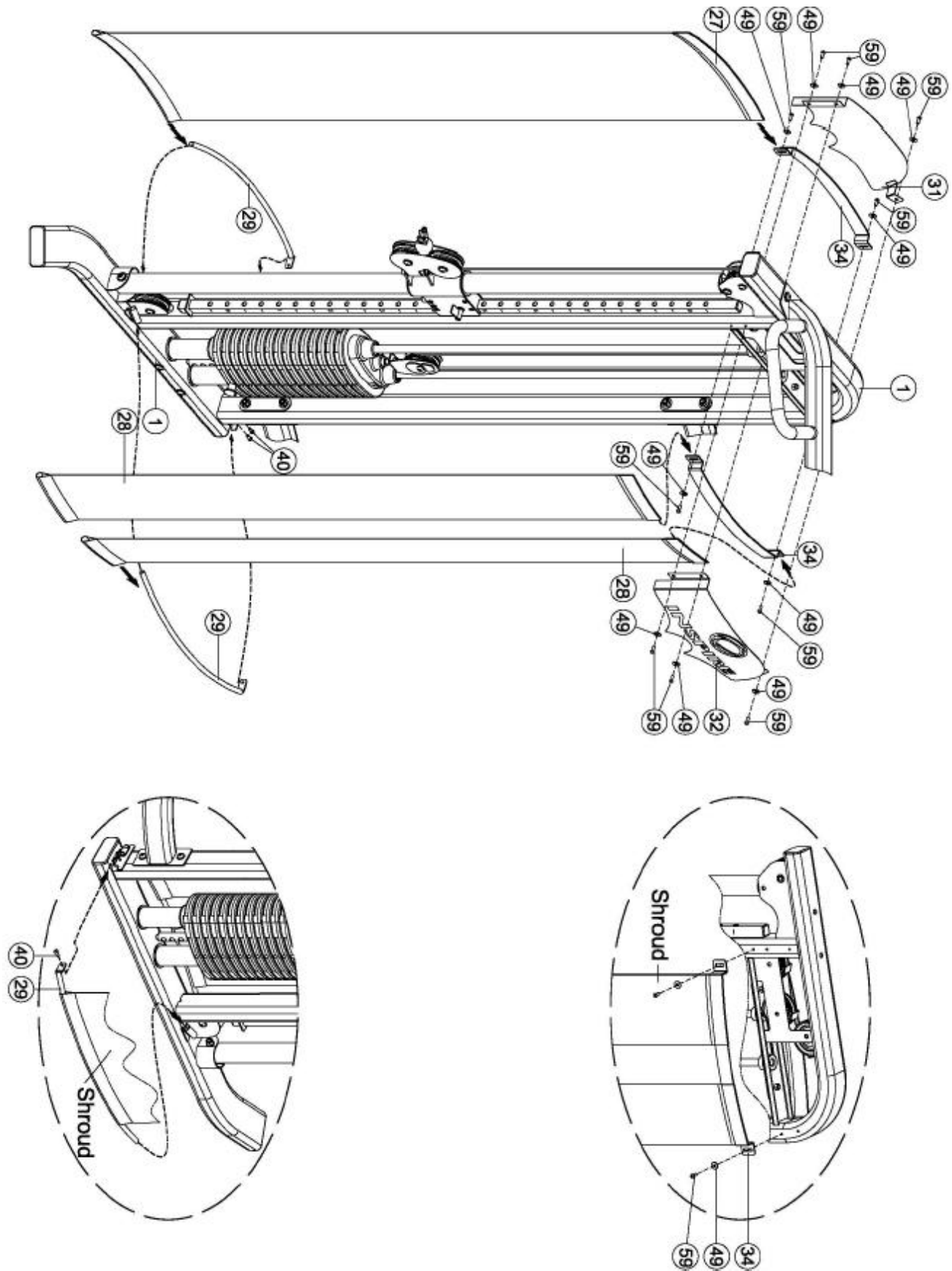

STEP 5 (See Diagram 5)

A.) Attach one Exercise Chart Hanger Bracket (#8) to the Right Station (#1). Secure it with two M6 x 5/8" Allen Bolts (#40) and \emptyset 3/4 " Washers (#51). Do not tighten the Bolts yet.

B.) Slide the Flip Exercise Chart (#57) onto the Exercise Chart Hanger (#15).

C.) Attach the Hanger (#15) to the Bracket (#8).

D.) Secure the other Bracket (#8) to the Left Station (#2) with two M6 x 5/8" Allen Bolts (#40) and \emptyset 3/4 " Washers (#51).

E.) Securely tighten all Bolts installed.

F.) Hang the Sports Handle (#21), both 5lb. Add-on Weights (#63), Chin Up Belt (#25) & Ankle Strap (#26) onto Upper & Middle Hanger.

Diagram 5

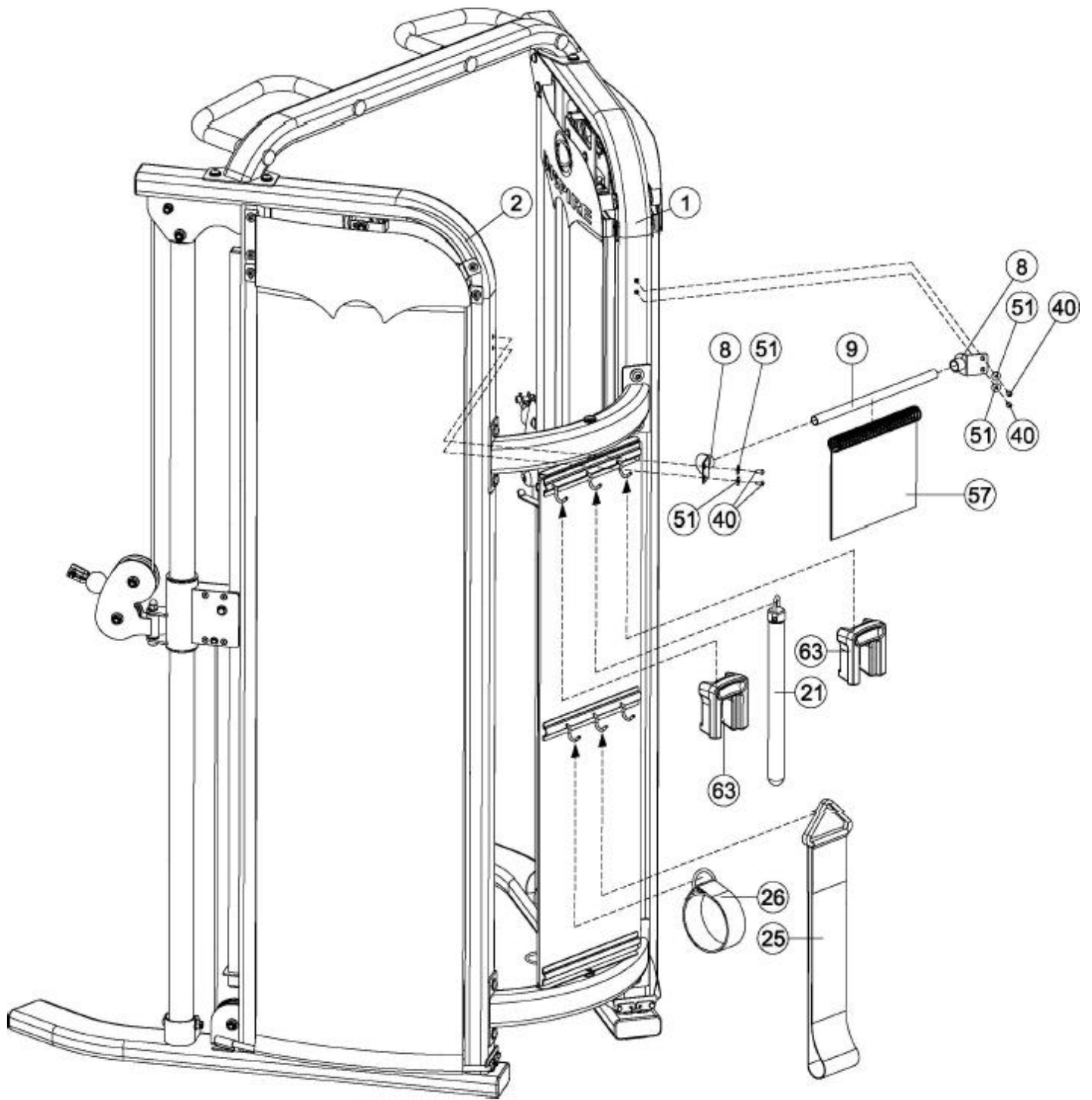

STEP 6 (See Diagram 6)

A.) Attach the Height Adjustment Handle (#36) to the Right Lock Switch (#10) on the Pulley Carriage (#8) Not Shown on Diagram. Secure it with one M5 x 3/8" Allen Bolt (#45). Repeat the same procedure to install the other side.

B.) Connect the Single Handle (#24) to the Cable (#2) on the Right Station (#1) with a Spring Clip (#39). Repeat the same procedure to install the other side.

C.) Replace the Single Handle with the Ankle Strap (#26), or Sports Handle (#21) for various Leg Exercises.

D.) Lift up the Height Adjustment Handle (#36) and slide the Pulley Carriage (#8) along the Pulley Carriage Support Frame to the selected level. Release the Handle to lock the Pulley Carriage in position.

E.) Store Curl Bar (#22), Straight Bar (#23), Rope (#20) onto the Upper and Lower Hanger Bracket (#14) & (#15).

Diagram 6

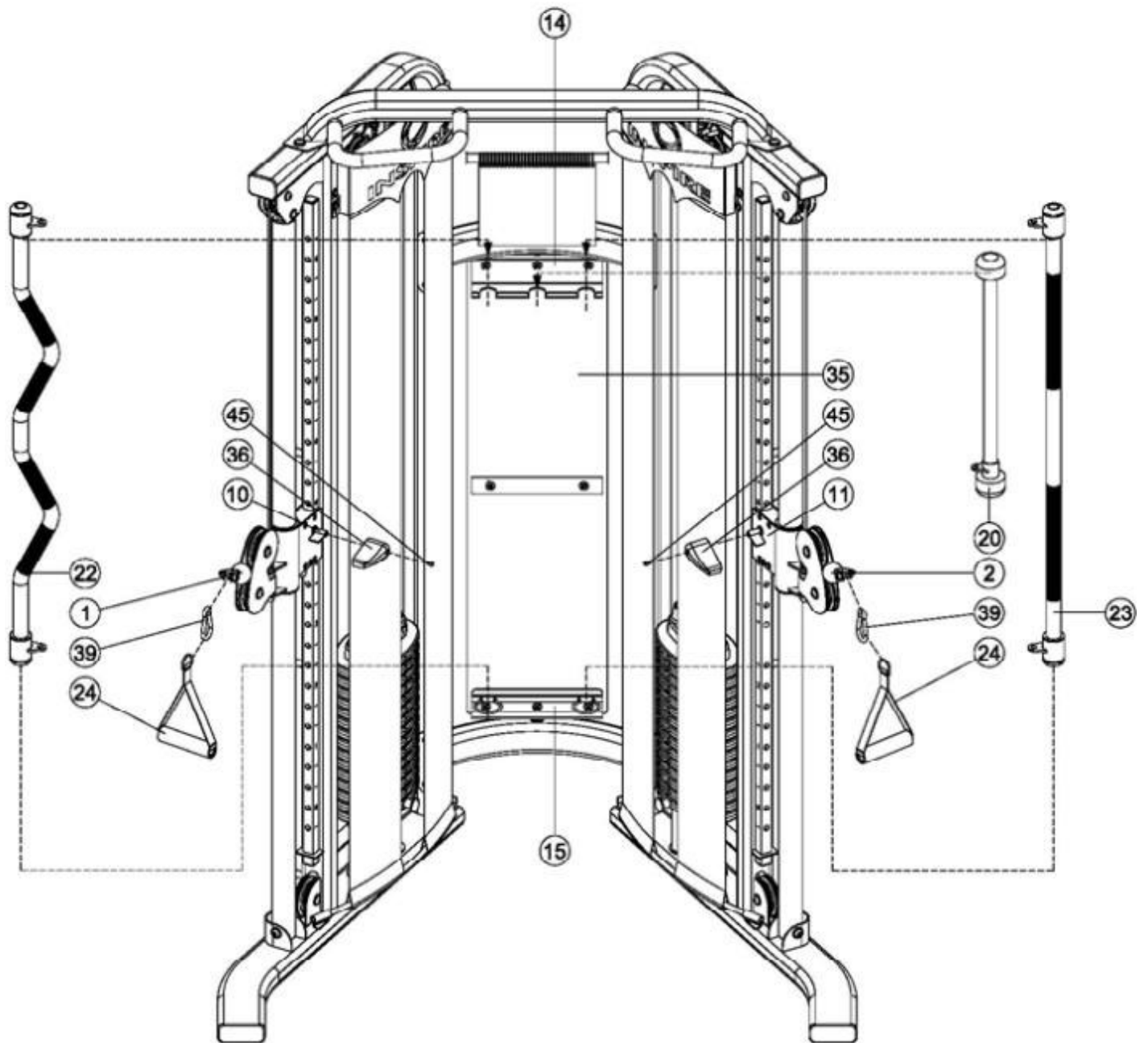

EXPLODED DIA ग. २A

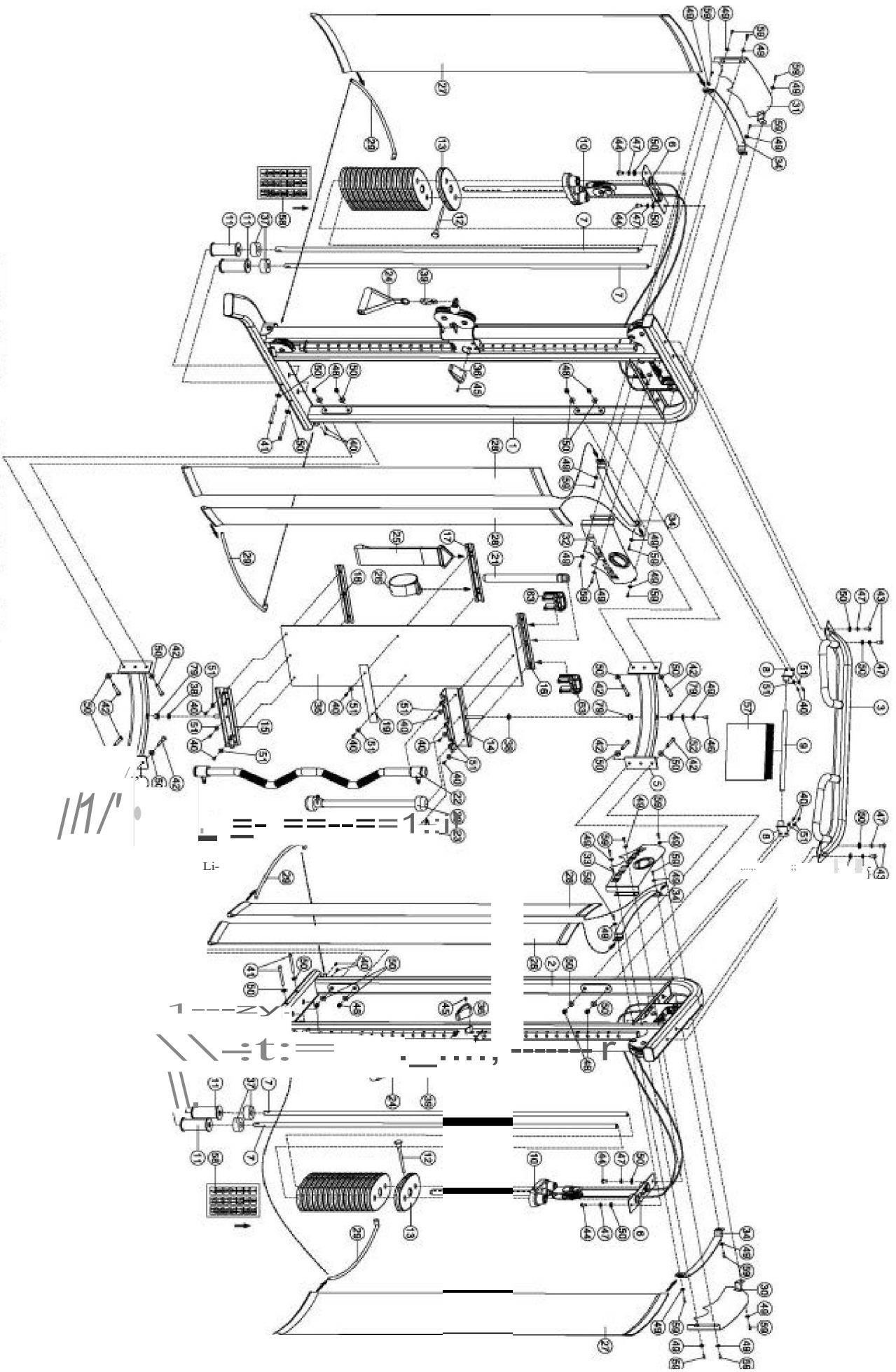

GENERAL MAINTENANCE INFORMATION

Warning: DO NOT place styrofoam or printed materials on the orthopedic seat pads. Over time, these may stick to the pads and mar the surface.

Do not leave items sitting on the orthopedic seat pads, these pads have a special density that takes shape to objects and small objects will leave imprints in the surface that may take time to come out.

- Periodically inspect the cables for splitting, cracking or fraying. Also, watch for bulging or flat areas in the cable.
- Immediately replace cables at the first signs of damage or wear. Never use equipment with damaged or worn cables.
- Cables naturally stretch over time, so check cable slack periodically and adjust cable tension as needed.
- Regularly inspect product for loose hardware.
- Do not use or store equipment outdoors.
- Inspect snap links, swivels, handles and weight stack pin for wear or damage. If wear or damage exists, replace immediately.
- Locate and familiarize yourself with all warning decals on the home gym.
- Replace damaged or worn upholstery immediately.
- Periodically wipe down guide rods with a dry cloth and re-apply a thin coat of a teflon-based lubricant.

MAINTENANCE SCHEDULE

ROUTINE	HOME MAINTENANCE	ENTRY DATE									
Inspect: Links, Pull Pins, Snap Links, Swivels, Weight Stack Pins	WEEKLY										
Clean: Upholstery	WEEKLY										
Inspect: Cables and their Fittings	WEEKLY										
Inspect: Tautness of all Shrouds	WEEKLY										
Inspect: Accessory Bars and Handles	3 MONTHS										
Inspect: All Decals	3 MONTHS										
Inspect: All Nuts and Bolts. Tighten if Needed	3 MONTHS										
Inspect: Anti-Skid surfaces	3 MONTHS										
Clean and Lubricate: Guide Rods with a Teflon based lubricant	3 MONTHS										
Lubricate: Seat Sleeves and all Plastic Slides	3 MONTHS										
Clean and Wax: All Glossy Finishes	YEARLY										
Replace: Cables, Belts and Connecting Parts	2 YEARS										

LIMITED WARRANTY

INSPIRE

In-Home Lifetime Warranty.

This Warranty applies only in the United States to Inspire strength products manufactured or distributed by Health In Motion LLC. The warranty period to the original purchaser is lifetime of the original purchaser.

Health In Motion warrants that the Product you have purchased for non-commercial, personal, family or household use from Health In Motion LLC or from an authorized Health In Motion reseller is free from defects in materials or workmanship under normal use during the warranty period. Your sales receipt, showing the date of purchase of the Product, is your proof of the date of purchase. This warranty extends only to you, the original purchaser. It is not transferable to anyone who subsequently purchases the Product from you. It excludes expendable parts such as paint and finish. This Warranty becomes VALID ONLY if the Product is assembled / installed according to the instructions / directions included with the Product.

Replacement and repair of parts.

During the warranty period Health In Motion will at no additional charge, repair or replace the Product if it becomes defective, malfunctions, or otherwise fails to conform with this Warranty under normal non-commercial, personal, family, or household use. In repairing the product Health In Motion may replace defective parts with, at the option of Health In Motion, serviceable used parts that are equivalent to new parts in performance, or new parts. All exchanged parts and Products replaced under this warranty will become the property of Health In Motion. Health In Motion reserves the right to change manufacturers and or specification of any part to cover any existing warranty.

Service procedures.

To obtain warranty parts, you must return the parts to Health In Motion or an authorized Health In Motion retailer in its original container (or equivalent). You must pre-pay any shipping charges, taxes, or any other charges associated with transportation of the Product. In addition, you are responsible for insuring any Product shipped or returned. You assume the risk of loss during shipment. You must present Health In Motion with proof-of-purchase documents (including the date of purchase, Model, and Serial Number). Any evidence of alteration, erasing or forgery of proof - of-purchase documents will be cause to void this Warranty.

Conditions and Exceptions.

This Warranty does not extend to any Product not purchased from Health In Motion LLC or from an authorized Health In Motion reseller. This Warranty does not extend to any Product that has been damaged or rendered defective; (a) as a result of accident, misuse, or abuse; (b) by the use of parts not manufactured or sold by Health In Motion; (c) by modification of the Product; (d) as a result of service by anyone other than Health In Motion, or an authorized Health In Motion warranty service provider; (e) product that has not been properly maintained (follow maintenance schedule found on product). Should any product submitted for Warranty service be found to be ineligible, an estimate of repair cost will be furnished and the repair will be made if requested by you upon Health In Motion receipt of payment or acceptable arrangement of payment.

Disclaimer

EXCEPT AS EXPRESSLY SET FORTH IN THIS WARRANTY HEALTH IN MOTION MAKES NO OTHER WARRANTIES; EXPRESSED OR IMPLIED INCLUDING ANY IMPLIED WARRANTIES OF MERCHANTABILITY AND FITNESS FOR A PARTICULAR PURPOSE. HEALTH IN MOTION EXPRESSLY DISCLAIMS ALL WARRANTIES NOT STATED IN THIS WARRANTY. ANY IMPLIED WARRANTIES THAT MAY BE IMPOSED BY LAW ARE LIMITED TO THE TERMS OF THIS WARRANTY. NEITHER HEALTH IN MOTION NOR ANY OF ITS AFFILIATES SHALL BE RESPONSIBLE FOR INCIDENTAL OR CONSEQUENTIAL DAMAGES. HEALTH IN MOTION IS NOT RESPONSIBLE FOR THE REPAIR OR REPLACEMENT OF ANY PARTS THAT HEALTH IN MOTION DETERMINES HAVE BEEN SUBJECTED AFTER THE DATE OF MANUFACTURE TO ALTERATION, NEGLIGENCE, ABUSE, MISUSE, NORMAL WEAR & TEAR, ACCIDENT, DAMAGE DURING TRANSIT OR INSTALLATION, FIRE, FLOOD, OR ANY ACT OF GOD. SOME STATES DO NOT ALLOW LIMITATIONS ON HOW LONG AN IMPLIED WARRANTY LASTS OR THE EXCLUSION OR LIMITATION OF INCIDENTAL OR CONSEQUENTIAL DAMAGES, SO THE ABOVE LIMITATIONS OR EXCLUSION MAY NOT APPLY TO YOU. This Warranty gives you specific legal rights and you may also have other rights that may vary from state to state. This is the only express warranty applicable to Health In Motion's "Inspire" branded strength products. Health In Motion neither assumes nor authorizes anyone to assume for it any other express warranty.