

USER MANUAL

START HERE

SF3

**SMITH
MACHINE
FUNCTIONAL
TRAINER**

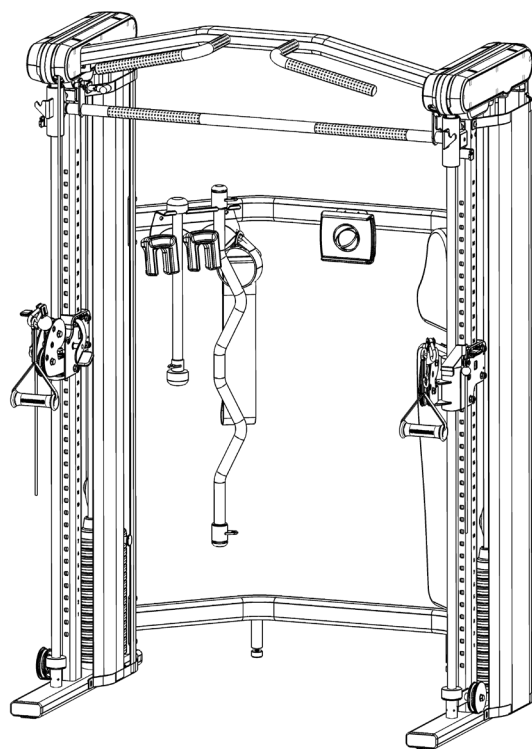

Record Serial Number Here

Health in Motion LLC
V03042022

CONGRATULATIONS

Welcome to the Inspire Fitness Family. You've just taken the first step to a healthier and stronger body. This SF3 Smith Machine Functional Trainer by Inspire Fitness offers the key to unlocking your body's potential. Regular training on a Smith Machine Functional Trainer has been shown to deliver a host of benefits including: increased muscle tone, decreased body fat, improved energy levels, and a reduction in stress. Congratulations, you are on your way to improving your self image, overall health, and quality of life.

BEFORE ASSEMBLING YOUR SF3

IMPORTANT: Read this entire manual before attempting to build or use this machine. This manual contains step by step instructions for proper assembly.

Use the parts list included in this manual to verify that all parts are accounted for before assembly. If any parts are missing, contact Inspire Fitness Support for replacement parts through email, by phone or through chat.

This Inspire Fitness SF3 Smith Machine Functional Trainer is intended for indoor use only. Rust can form on certain parts in a humid environment, resulting in impaired function.



Scan here to follow a step-by-step Assembly Video, or for more information about the SF3.

CONTACT US FOR HELP

Service of your SF3 Smith Machine Functional Trainer should only be performed by an Inspire Fitness Authorized Servicer. Service performed by anyone else can result in loss of warranty. If you need help finding an Inspire Fitness Authorized Servicer, please contact us directly:



Email

service@inspirefitness.com



Phone

877-738-1729 (US Only)

+1 714-738-1729 (International)

Mon-Fri 8am-5pm PT - UTC-7h/8h



Chat

www.inspirefitness.com

Support is provided in English and Spanish

REGISTER WARRANTY ONLINE

To register your product for warranty, visit inspirefitness.com/support.

TABLE OF CONTENTS

IMPORTANT SAFETY NOTICE.....	5
ASSEMBLY AND SETUP.....	6
ASSEMBLY INSTRUCTIONS.	10
FEATURES AND FUNCTIONS.....	18
LABEL PLACEMENT.	19
CONNECTING TO THE INSPIRE APP.	20
MAINTENANCE.....	20
WARRANTY.	21
EXPLODED VIEW.....	22
PARTS LISTS.....	23
FLB2C FOLDING ADJUSTABLE BENCH USER MANUAL.	24

IMPORTANT SAFETY NOTICE

PRECAUTIONS

This exercise machine is built for optimum safety. However, certain precautions apply whenever you operate a piece of exercise equipment. Be sure to read the entire manual before you assemble or operate your machine. Please note the following safety precautions:

1. Always keep children and pets away from the machine. DO NOT leave children unattended in the same room with the machine. The cabling and moving parts on this machine can cause serious injury or death if used improperly.
2. Only one person at a time should use the machine.
3. If the user experiences dizziness, nausea, chest pain, or any other abnormal symptoms, STOP the workout at once. CONSULT A PHYSICIAN IMMEDIATELY.
4. Position the machine on a clear, leveled surface. DO NOT use the machine near water or outdoors.
5. Keep hands away from all moving parts.
6. Always wear appropriate workout clothing when exercising. DO NOT wear robes or other loose clothing that could become caught in the machine. Running or training shoes are also required when using the machine.
7. Use the machine only for its intended use as described in this manual. DO NOT use attachments not recommended by the manufacturer.
8. Do not place any sharp objects around the machine.
9. Disabled persons should not use the machine without a qualified person or physician in attendance.
10. Before using the machine to exercise, always do stretching exercises to properly warm up.
11. Never operate the machine if the machine is not functioning properly.

Care and Maintenance

- Inspect and tighten all parts before using the machine.
- The Frame and Seat Pad of the machine can be cleaned using a damp cloth and mild non-abrasive detergent. DO NOT use solvents.

WARNING: BEFORE BEGINNING ANY EXERCISE PROGRAM, CONSULT YOUR PHYSICIAN. THIS IS ESPECIALLY IMPORTANT FOR INDIVIDUALS OVER THE AGE OF 35 OR PERSONS WITH PRE-EXISTING HEALTH PROBLEMS. READ ALL INSTRUCTIONS BEFORE USING ANY FITNESS EQUIPMENT. Health In Motion, LLC. DOES NOT ASSUME ANY RESPONSIBILITY FOR PERSONAL INJURY OR PROPERTY DAMAGE SUSTAINED BY OR THROUGH THE USE OF THIS PRODUCT.

ASSEMBLY AND SETUP

Package Contents

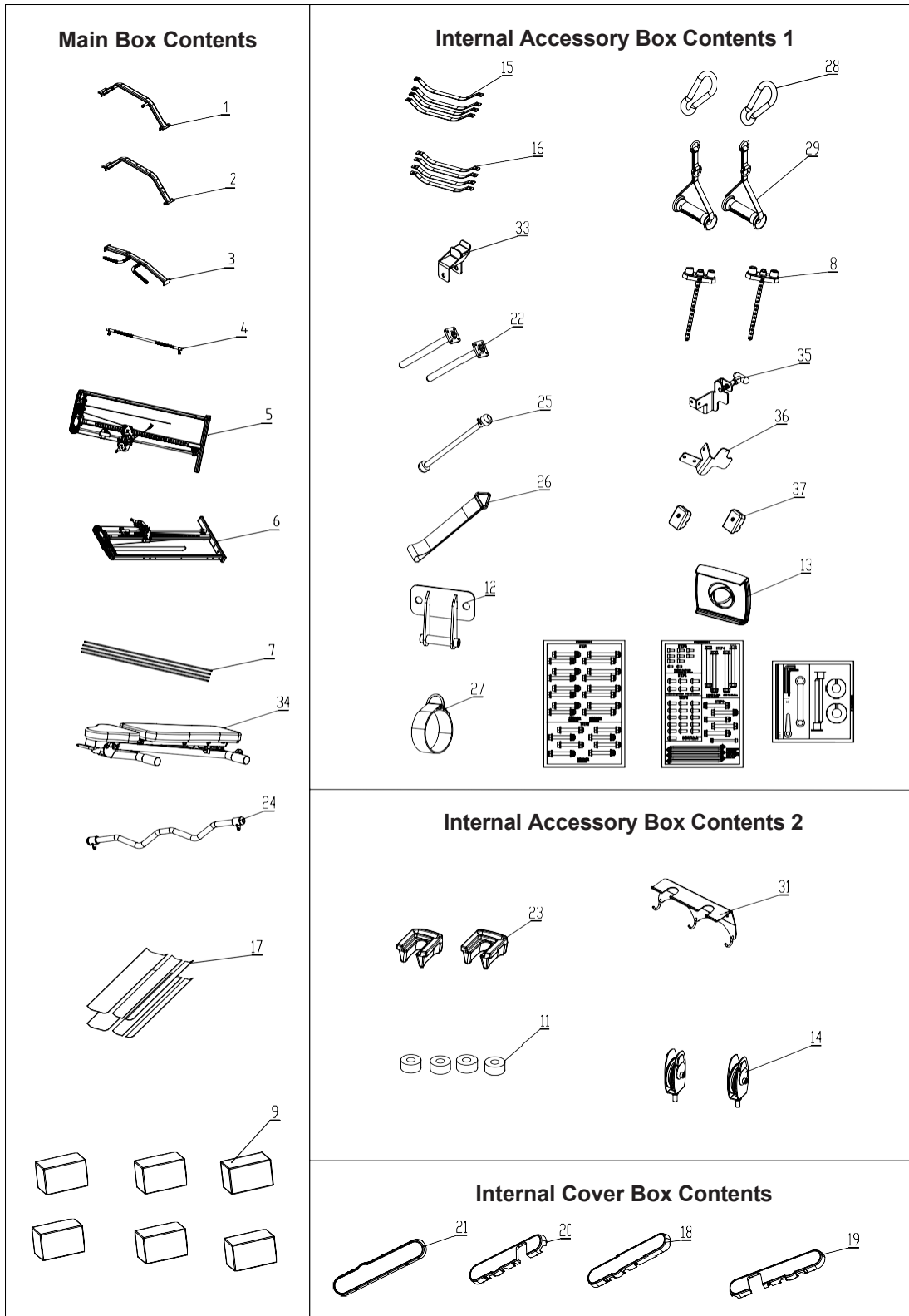

Assembly Hardware Kit

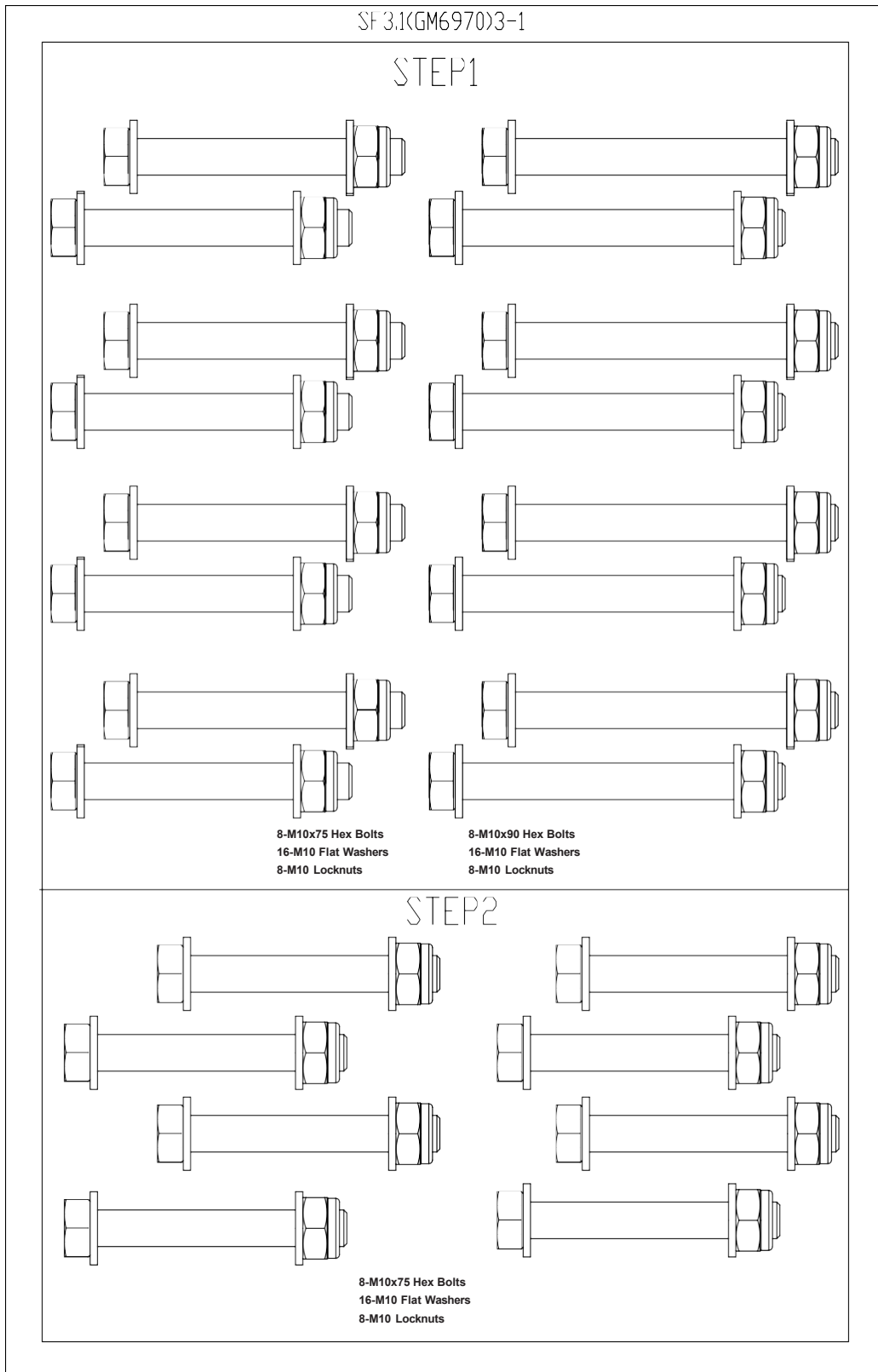

SF3.1(GM6970)3-2

STEP 3

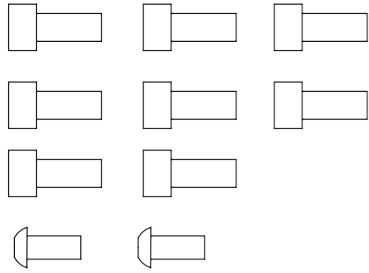

8-M6x14 Allen Head Screws
2-M5x14 Phillips Head Screws

STEP 6

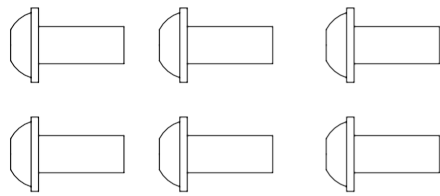

6-M8x20 Phillips Head Screws
6-M8 Flat Washers

STEP 8

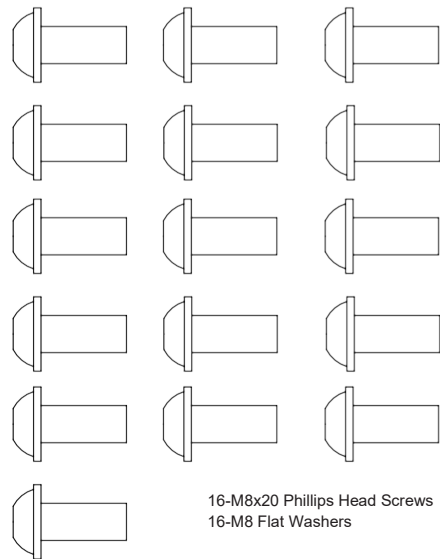

16-M8x20 Phillips Head Screws
16-M8 Flat Washers

STEP 4

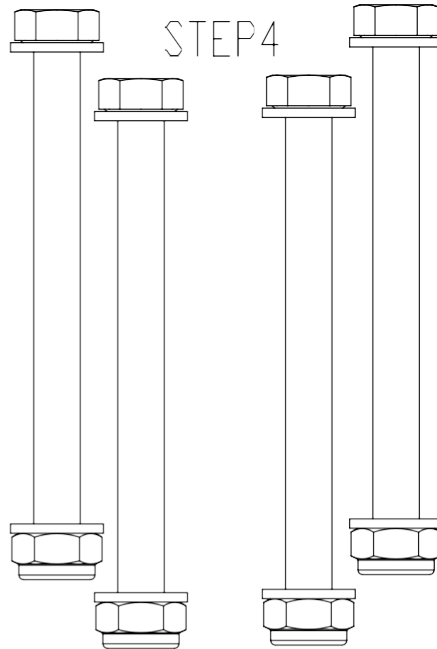

4-M10x115 Phillips Head Screws
4-M10 Locknuts
8-M10 Flat Washers

STEP 9

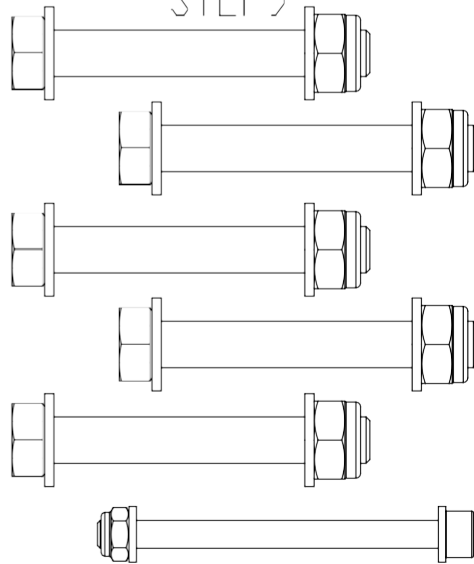

5-M10x75 Hex Bolts
10-M10 Flat Washers
5-M10 Locknuts
1-M6x75 Allen Bolts
2-M6 Flat Washers
1-M6 Locknuts
6-Cable Ties

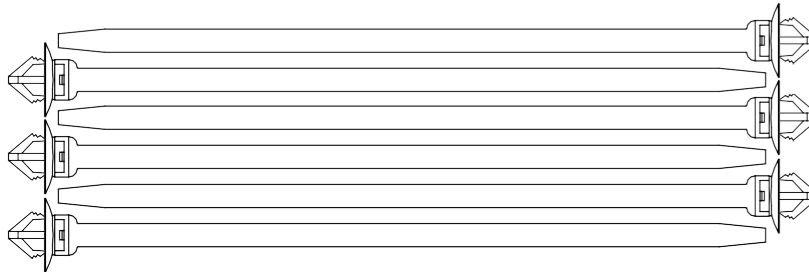

SF3.1(GM6970)3-3

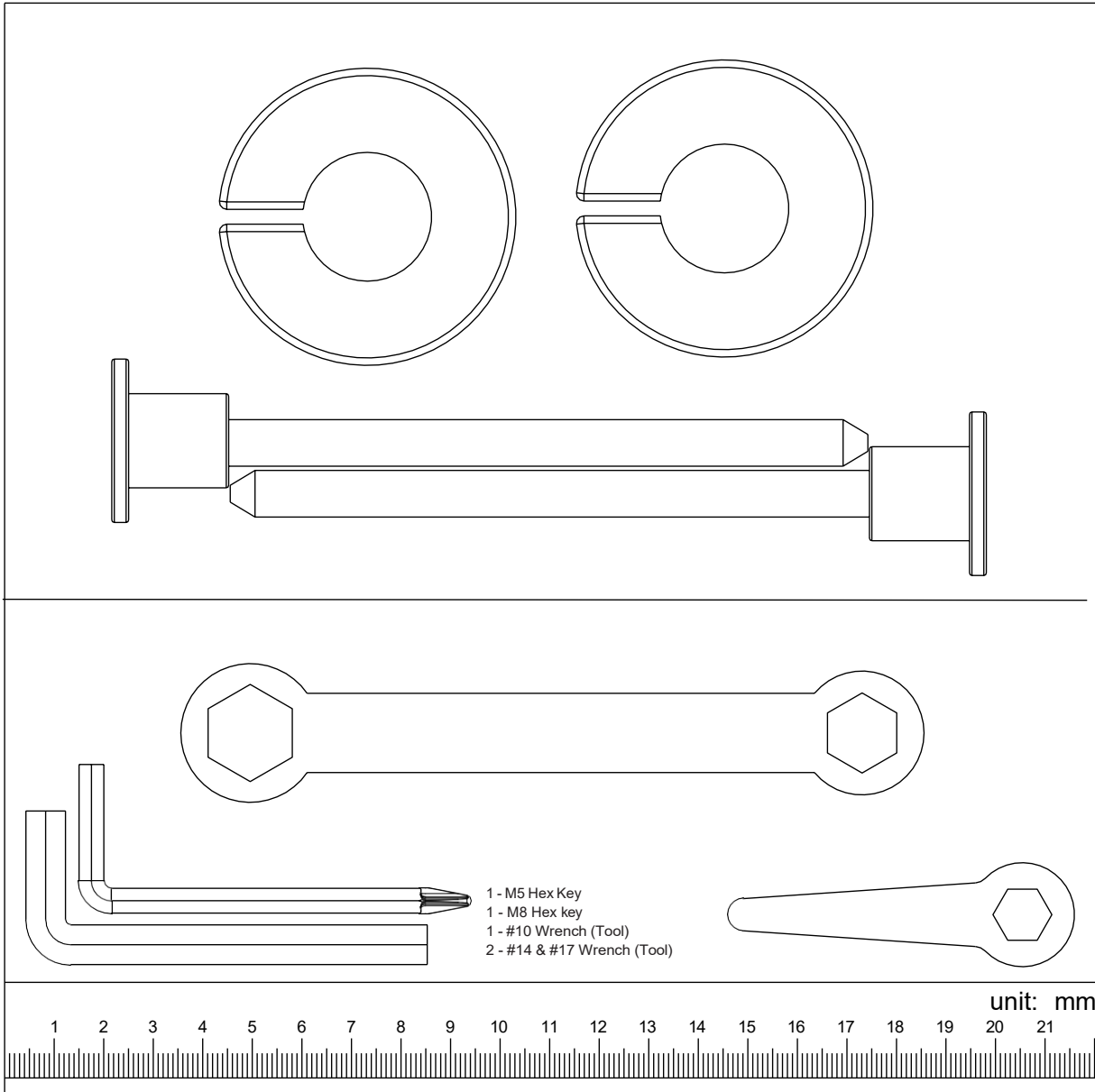

ASSEMBLY INSTRUCTIONS

STEP 1

A. Make sure any packing material or supports are removed from the frames prior to assembly. Start by placing the **Right Main Frame (6)** in the vertical position. Having a second person to hold the frame is helpful or you can possibly lean the frame against a wall. Insert two **M10x75mm Hex Bolts (39)** through the bottom **Lower Crossbar (1)** into the back of the **Right Main Frame (6)**, using **M10 Flat Washers (43)** on both sides and **M10 Locknuts (42)** hand tightened. Next insert two **M10x90mm Hex Bolts (40)** into the side of the bottom **Lower Crossbar (1)** and **Right Main Frame (6)**, using **M10 Flat Washers (43)** on both sides and **M10 Locknuts (42)** hand tightened.

B. Place the **Left Main Frame (5)** in the vertical position and align it with the lower rear **Lower Crossbar (1)**. Insert the hardware as described in the step above.

C. Repeat the steps above to attach the **Upper Crossbar (2)** to the **Right and Left Main Frames (6) (5)** similar to the lower **Lower Crossbar (1)** steps. **DO NOT TIGHTEN THE HARDWARE AT THIS TIME.**

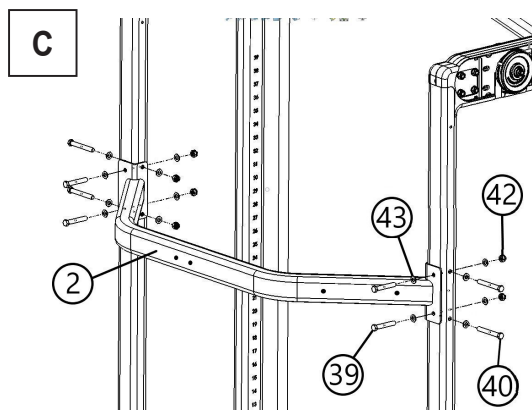
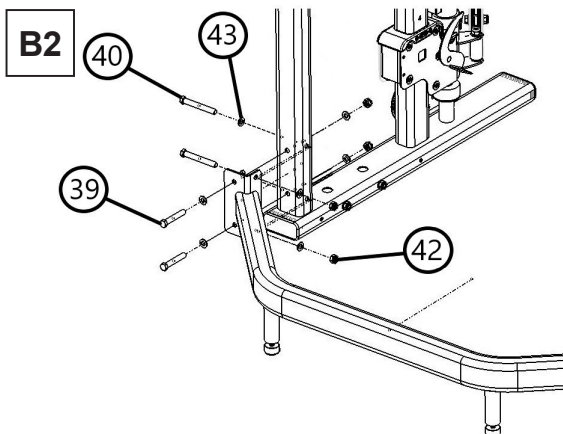
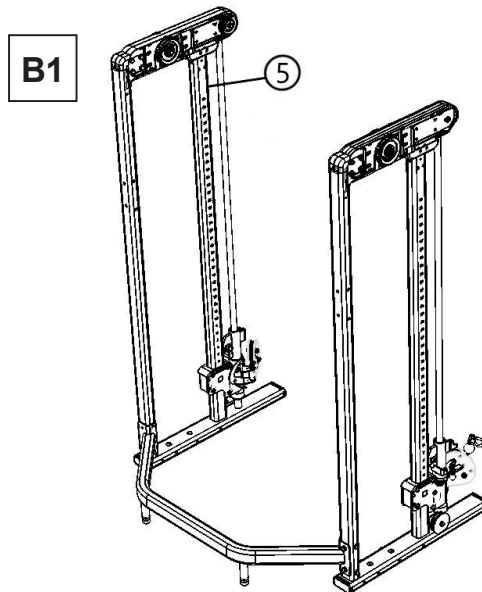
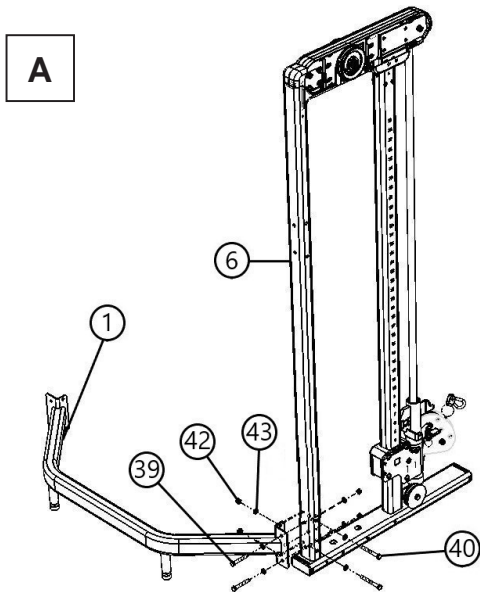

STEP 2

Place the **Pull-up Crossbar (3)** in position between the two main frames and insert four **M10x75mm Hex Bolts (39)** with **M10 Flat Washers (43)** through each main frame. Place **M10 Flat Washers (43)** and **M10 Locknuts (42)** onto the bolts. **DO NOT TIGHTEN THE HARDWARE AT THIS TIME.**

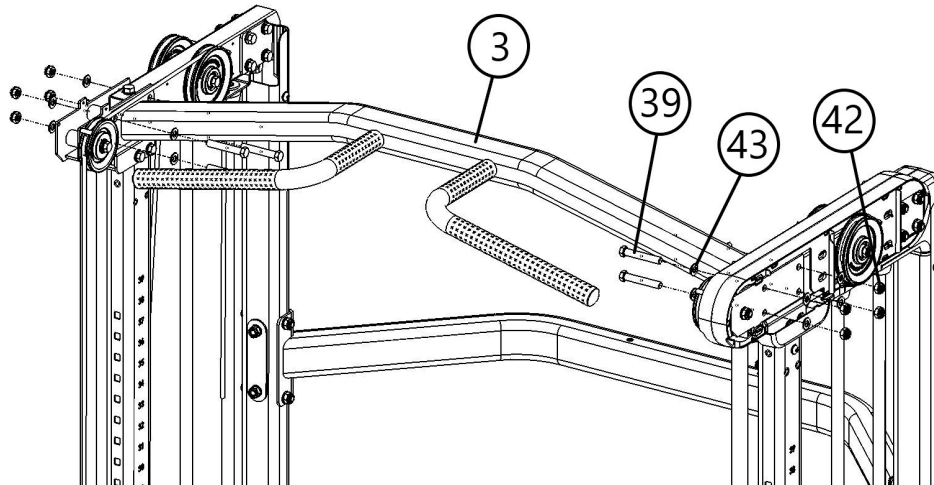

STEP 3

Lock the sliding carriages on the lowest (number 1) position. Place the **Smith Bar (4)** in between the rail slide mounts of the frame. Make sure the through hole on the tabs of the bar is positioned as shown. Insert the **Smith Bar Pins (22)** through both the **Right, Left Smith Bar Sliders (60), (62)** and into either end of the **Smith Bar (4)**. Use four **M6 Allen Head Screws (47)** on both sides to secure the **Smith Bar Pins (22)** to the **Smith Bar Sliders (60), (62)**. Next place the plastic **Smith Bar End Caps (37)** over the **Smith Bar Pins (22)** and secure with one **M5x14mm Phillips Head Screw (50)** per side. Make sure the machine is on level ground and **proceed to tighten all hardware installed in steps 1-3.** Adjust the two rear feet if needed to level the machine after tightening the hardware.

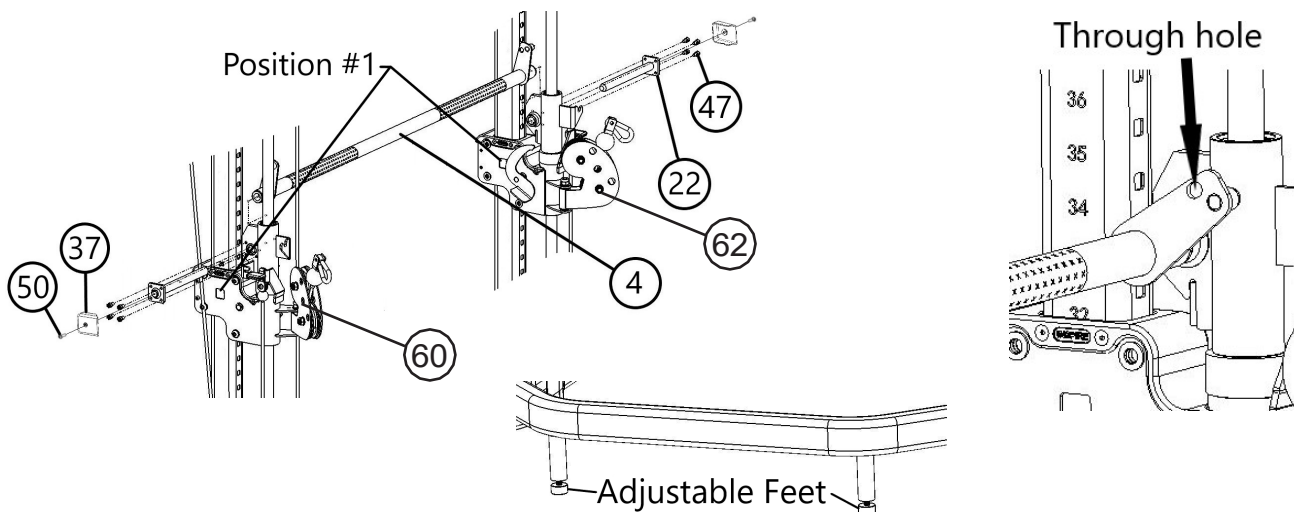

STEP 4

A. Thread the **Weight Stack Pulley (14)** into the top of both the **Top Plate Assembly (8)**, leave about a ¼ inch of thread.

B. Insert the **Weight Stack Guide Rods (7)** through the holes in the bottom of the frame. Be sure the ends of the rods with the holes are facing down, and do your best to align them with the holes in the frame. Then slide one **Rubber Bumper (11)** down each of the guide rods until they are resting on the bottom frame.

C. Let the **Weight Stack Guide Rods (7)** rest at an angle in the frame. Using the provided lubricant, spread the liquid up and down the guide rods. Then slide on 15 **Weight Stack Plates (9)** with the sticker cut out facing towards the inside of the machine and the protruding pads on the weights facing downward. Next slide on the **Top Plate Assembly (8)** assembly. Slide on the **Guide Rod Bushings (10)**, one on each rod, the tapered end of the bushing points downward. Repeat this step for the opposite side.

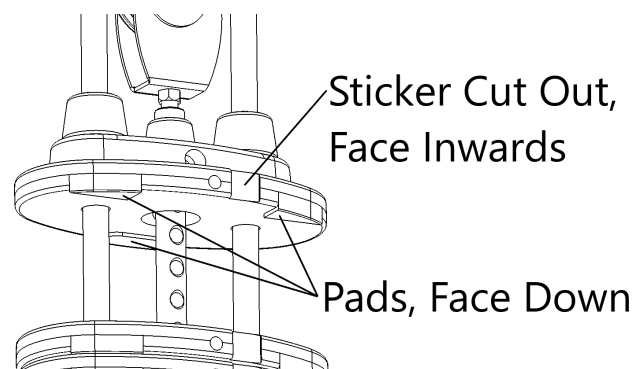
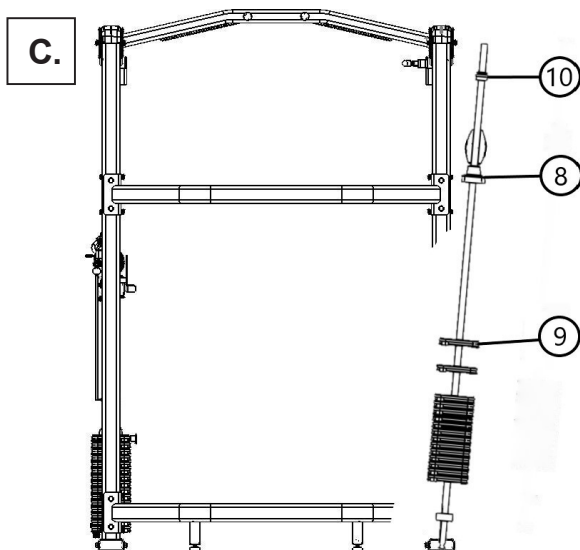
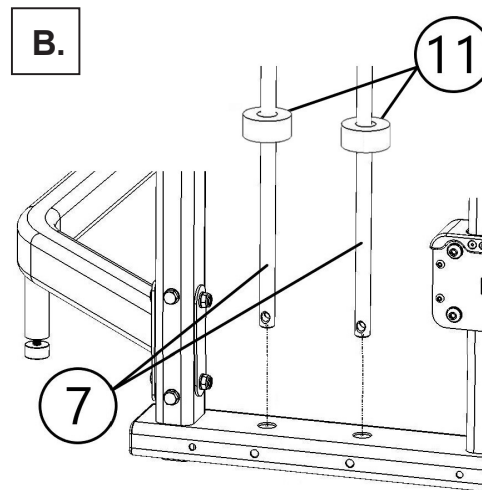
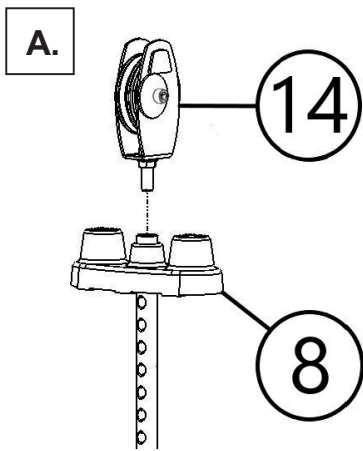

STEP 4 (Continued)

D. Make sure the cable that runs from either side of the frame is positioned between the two guide rods. Carefully pull the guide rods toward each other, then slide the **Guide Rod Bushings (10)** up into the larger hole of the frame until the slot of the bushing is resting in the frame. Next pull the bushings along with the rods away from each other so that the bushings slide into the smaller hole of the frame, thus locking them in place. The guide rods should be parallel to one another at this point.

E. Slide the **Weight Stack Guide Rods (7)** up so that the holes in the bottom of the rods align with the holes in the bottom of the frame. Insert two **M10x115mm Hex Bolts (41)** with **M10 Flat Washers (43)** through the frame and holes in the bottom of the rods. Place **M10 Flat Washers (43)** and **M10 Locknuts (42)** onto the bolts and tighten them. Repeat this step for the opposite side.

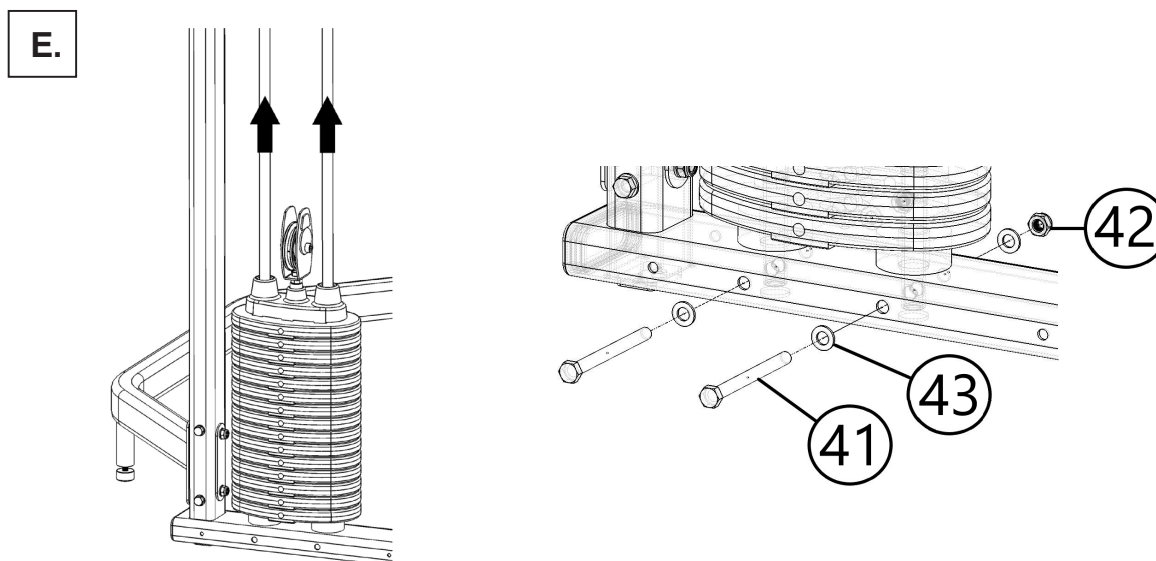
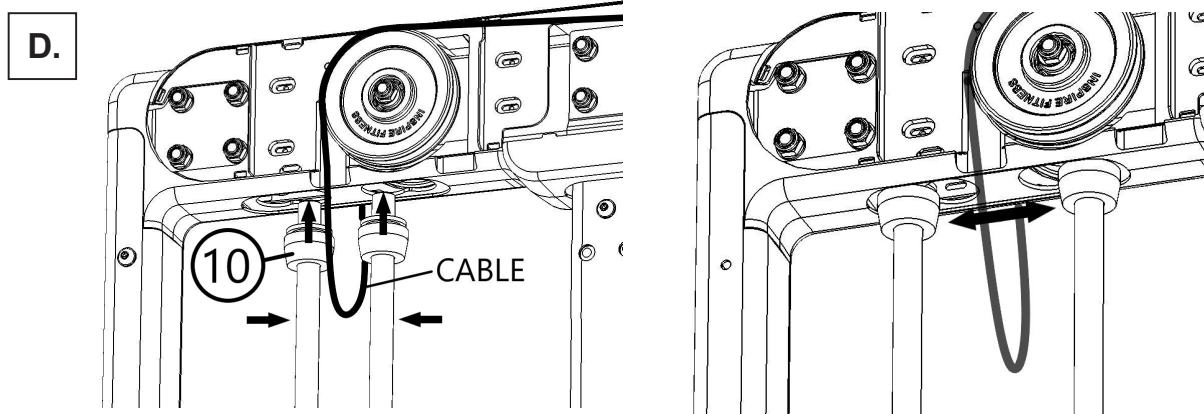

STEP 5

A. Route the cable as shown. Remove the pulley from the **Weight Stack Pulley (14)** assembly in order to route the cable into it, leave the hardware loose.

B. Adjust the cable tension by rotating the cam bolt until the **Top Plate Assembly (8)** starts lifting slightly from the weight stack. Tighten the nut of the cam bolt to lock it's position. Then tighten the jam nut at the base of the pulley.

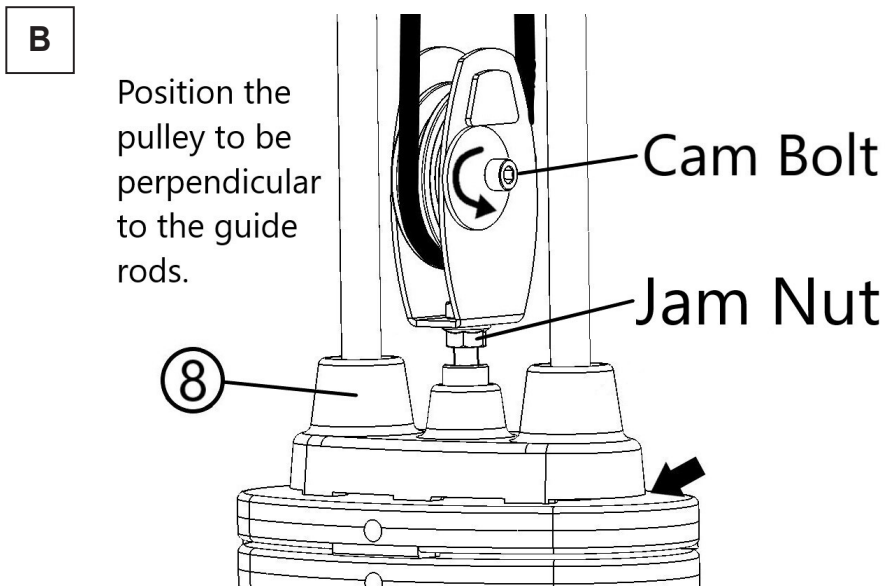
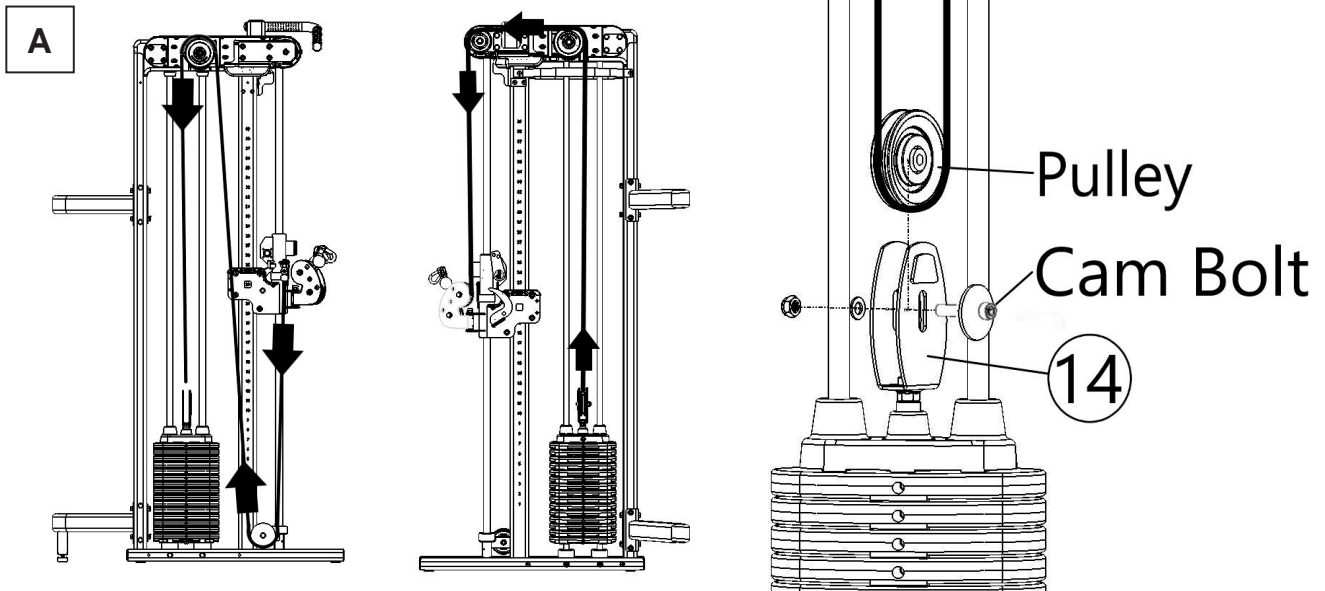

STEP 6

Bolt the smith bar hooks to each side of the main frames. The **Right Smith Bar Hook (35)** is the mount with the locking pin, the **Left Smith Bar Hook (36)** is the mount without the pin. Use three **M8x20 Buttonhead Cap Screws (44)** with **M8 Washers (45)** per hook to attach to them to the frame as shown.

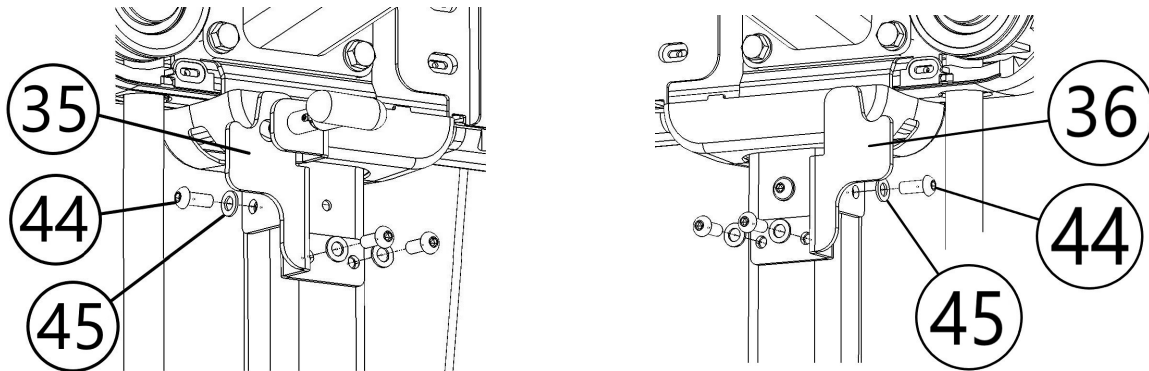
**WARNING**

Securely lock the Smith Bar in the storage position whenever it is not in use. Be sure to use the lock pin.

STEP 7

Install the **Outer Right Plastic Cover (18)**, and **Inner Right Plastic Cover (19)** as shown. Carefully align and press on the covers until they clip into place. Repeat this step with the **Outer Left Plastic Cover (21)** and **Inner Left Plastic Cover (20)**.

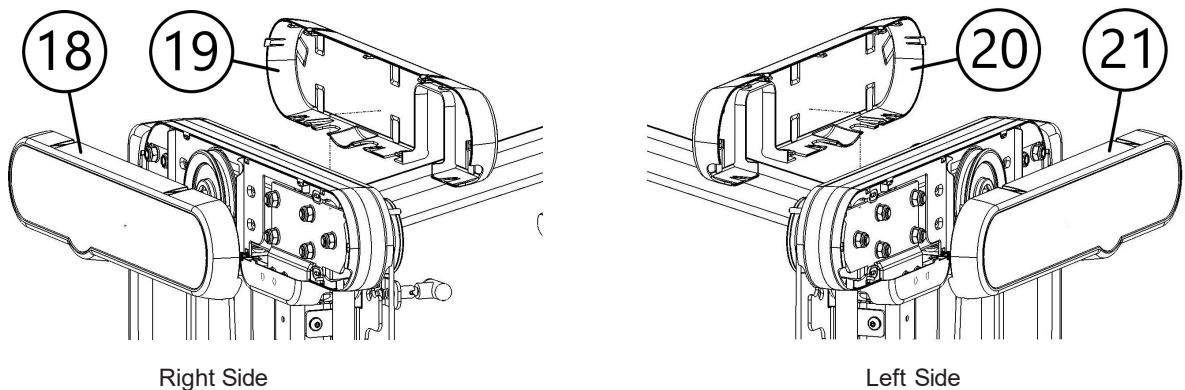

STEP 8

There are three different widths of weight stack shrouds. The widest **Shroud (17)** is placed on the outside facing part of the weight stack, the **Medium (17)** and **Narrow (17)** width shrouds are placed together on the inside, with the smaller placed toward the back of the machine. The mounting plates for them will be marked identifying the **Top Shroud Plate (15)**, **Bottom Shroud Plate (16)** and the forward direction of them, slide the plates through the pockets of the shrouds. Before applying the inner shrouds, apply the weight plate stickers. The number 1 sticker will go on the top plate, but we recommend that you start with the number 2 sticker. Place the number two sticker on the first weight plate. Then, apply the number 1 to the top weight plate assembly, using the #2 sticker to align it properly. Finish applying the stickers through 16. Secure the weight shrouds with **M8 x 20mm Button Head Cap Screw (44)** with **M8 Washers (45)** through the mount plates to the frame.

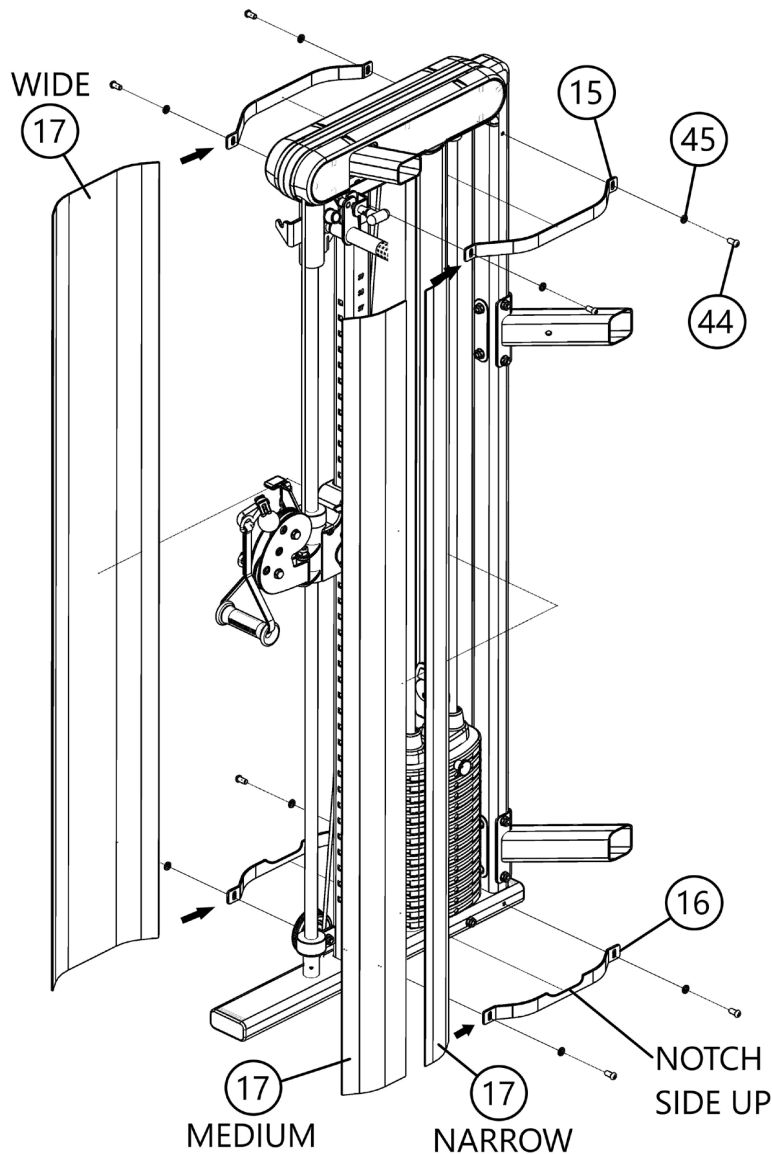

STEP 9

A. Place the **Accessory Rack (31)** on right side of the **Upper Crossbar (2)**. Insert two **M10 x 75mm Hex Bolts (39)** with **M10 Flat Washers (43)** through the rack and crossbar. Place **M10 Flat Washers (43)** and **M10 Locknuts (42)** onto the bolts. Tighten the hardware.

B. Place the **5 Lbs. Add-On Weight (23)**, **Dual Hook Curl Bar (24)**, **Triceps Rope (25)**, **Chin/Dip Belt (26)**, and **Ankle Strap (27)** on the accessory rack as shown. *Note: to use the 5 lbs. Add-On Weight place them on top of the weight stacks in between the pullies.*

C. Mount the **Tablet Mount (12)** in the middle of the **Upper Crossbar (2)**. Insert two **M10 x 75mm Hex Bolts (39)** with **M10 Flat Washers (43)** through the mount and **Upper Crossbar (2)**. Place **M10 Flat Washers (43)** and **M10 Locknuts (42)** onto the bolts, tighten the hardware. Place the Tablet Holder on to its mount and secure with a **M6x75mm Allen Head Cap Screw (46)** and **M6 Locknut (49)**, using **M6 Washers (48)** on both sides. Tighten hardware until tablet holder holds its position but can still be tilted up and down by hand. *Note: The Tablet holder mount can be bolted up or down depending on if you want the tablet holder higher or lower.*

D. Place the **Bench Mount (33)** on the left side **Upper Crossbar (2)**, insert one **M10 x 75mm Hex Bolt (39)** with a **M10 Flat Washers (43)** through the mount and **Upper Crossbar (2)**. Place one **M10 Flat Washers (43)** and a **M10 Locknut (42)** onto the bolt and tighten the hardware.

E. Optional: If you have electronics with cords, you can use the included cable clips to route the cables along the frame of the machine.

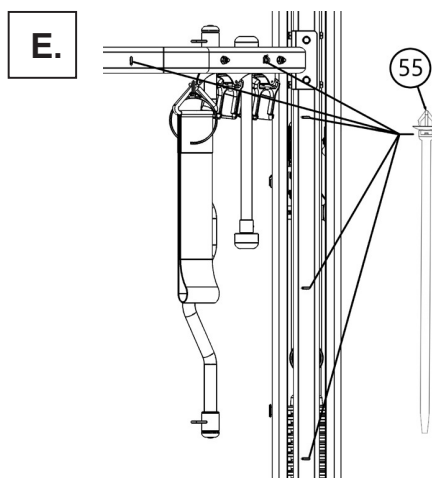
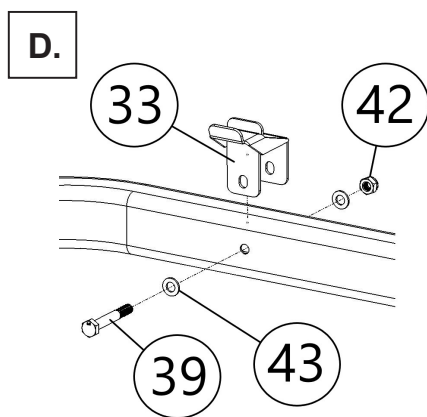
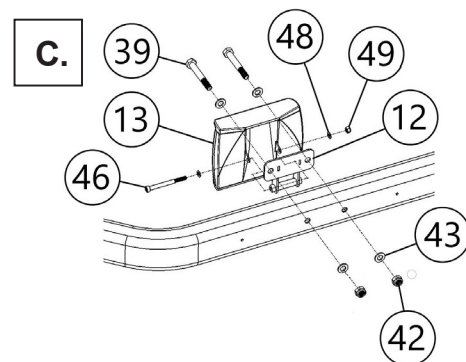
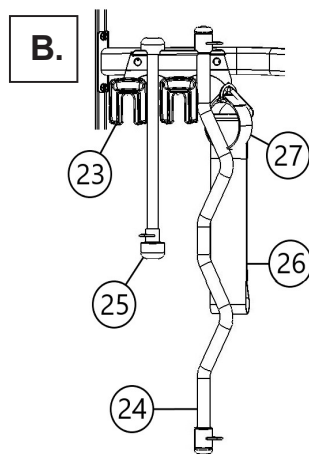
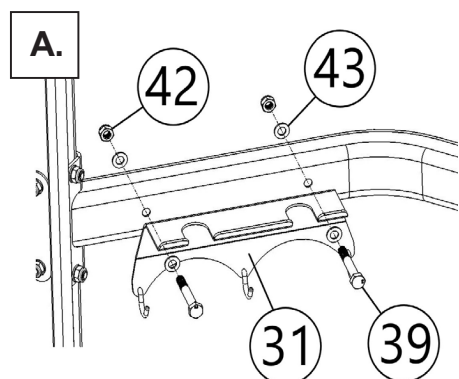

FEATURES AND FUNCTIONS

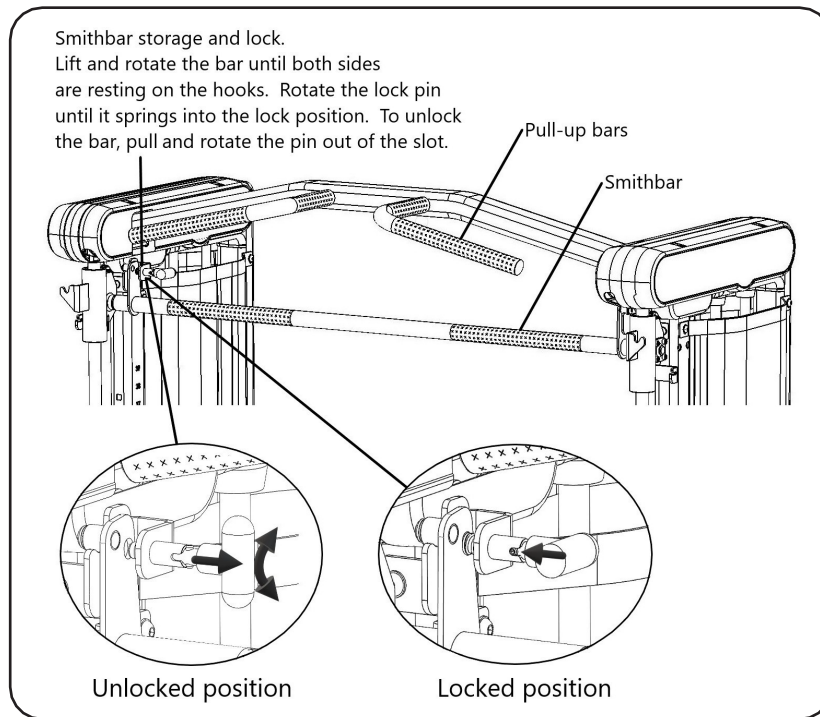

! WARNING

Securely lock the Smith Bar in the storage position whenever it is not in use. Be sure to use the lock pin.

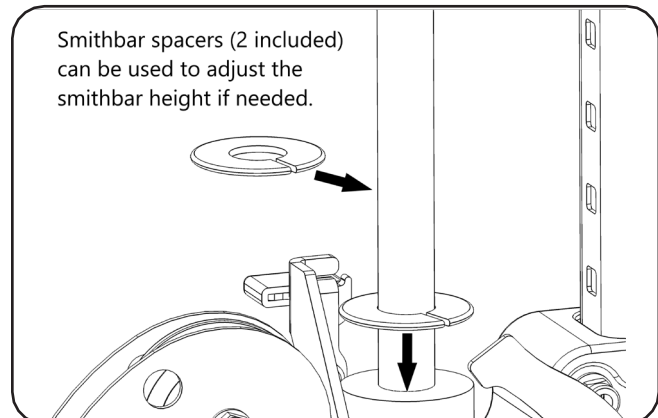
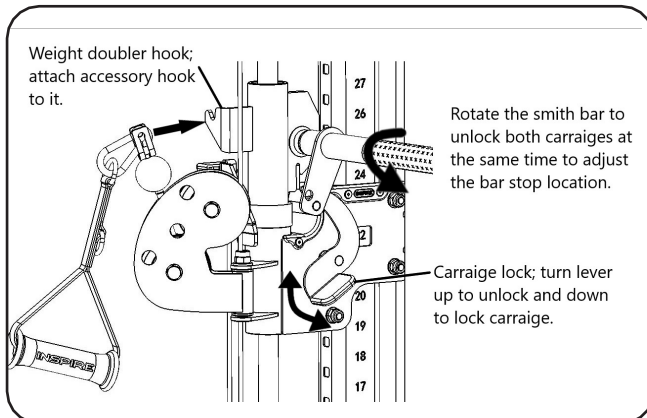
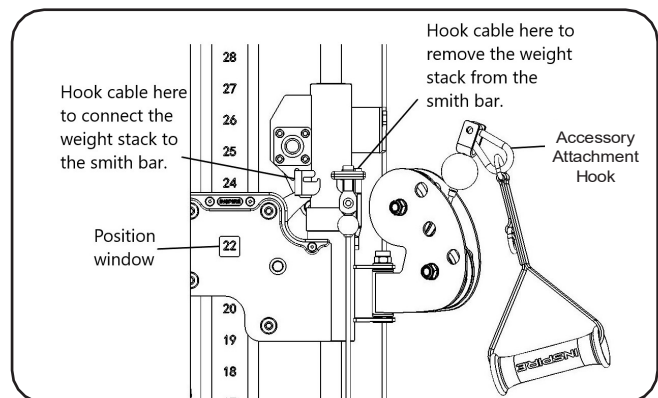
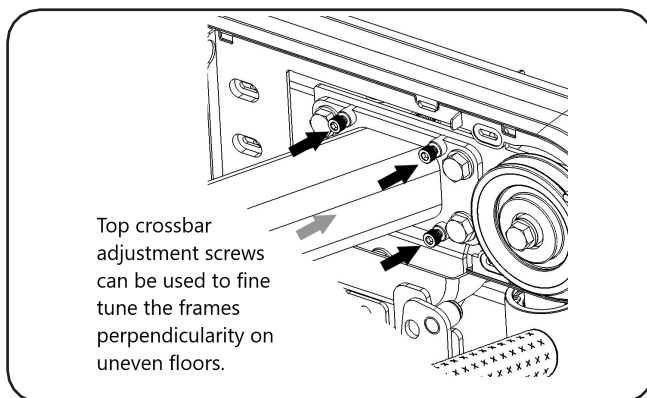

LABEL PLACEMENT

⚠ DANGER
PINCH POINT
 KEEP HANDS CLEAR

ENGAGE LOCK PIN WHEN THE BAR IS IN THE UP STOWED POSITION

⚠ WARNING

- ▶ SERIOUS INJURY CAN OCCUR ON THIS MACHINE IF THE LIFTING BAR IS NOT SECURED PROPERLY AND FALLS.
- ▶ USER MUST BE TRAINED ON USE OF, AND SECURING THE LIFTING BAR OVERHEAD.
- ▶ VISUALLY AND PHYSICALLY INSPECT BOTH RED HOOKS TO ENSURE THEY ARE COMPLETELY ENGAGED ON THE FRAME AND THAT THE LOCKING PIN IS IN THE LOCKED POSITION BEFORE LEAVING THE MACHINE.

⚠ DANGER
PINCH POINT
 KEEP HANDS CLEAR

⚠ WARNING

USE ONLY GENUINE INSPIRE REPLACEMENT PARTS. FAILURE TO DO SO WILL VOID WARRANTY AND COULD RESULT IN SERIOUS INJURY. THERE IS A RISK ASSUMED BY INDIVIDUALS WHO USE THIS TYPE OF EQUIPMENT. TO MINIMIZE THE RISK, ALWAYS FOLLOW THESE RULES.

1. READ & UNDERSTAND ALL ENCLOSED INSTRUCTIONS BEFORE USING THIS EQUIPMENT.
2. INSPECT EQUIPMENT BEFORE EACH USE. Replace parts that show any wear or damage. If in doubt about a certain part, DO NOT use the equipment until the part is replaced. Failure to replace worn or damaged parts may result in injury.
3. FOLLOW MAINTENANCE SCHEDULE on the "NOTICE" sticker.
4. CONSULT YOUR PHYSICIAN BEFORE STARTING ANY EXERCISE PROGRAM. Warm up properly before exercising. Stop exercising if you feel faint or dizzy.
5. TO PREVENT THE POSSIBILITY OF SERIOUS INJURY KEEP CLEAR OF ALL MOVING PARTS. DO NOT ATTEMPT TO FREE ANY JAMMED PART BY YOURSELF. Obtain assistance in order to avoid possible injury.
6. Take your time and do not rush exercise. Practice proper breathing. NEVER hold your breath.
7. CHILDREN SHOULD NOT BE ALLOWED TO USE THIS EQUIPMENT. To avoid possible injury, children should be kept at a safe distance when this equipment is in use. Teenagers should not use this equipment without adult supervision.
8. CALL YOUR AUTHORIZED INSPIRE DISTRIBUTOR if you have any questions on the proper use or maintenance of this equipment.

9. Make sure all Pull Pins, Locks, and Safety Latches are in place and fully engaged before each use.

NOTICE

This INSPIRE product is not intended for commercial use.

IN HOME MAINTENANCE	Weekly	Monthly	Quarterly	Yearly
Inspect; Links, Pull Pins, Snap Locks, Swivels, Weight Stack Pins	✗			
Clean; Upholstery	✗			
Inspect; Cables and their fittings	✗			
Inspect tightness of all shrouds	✗			
Inspect; Accessory Bars and Handles		✗		
Inspect; All Decals		✗		
Inspect; All nuts and Bolts Tighten if Needed.		✗		
Inspect; Anti-Skid Surfaces		✗		
Clean & Lubricate; Guide Rods with a Teflon(PTFE) based Lubricant (SuperLube)		✗		
Lubricate; Seat Sleeves and all plastic slides		✗		
Clean & Wax All Glossy Finishes			✗	
Replace; Cables, Belts and Connect Part.				✗

HEALTH IN MOTION, LLC

ADDRESS / ADDRESS / DIRECTION:
 255 AIRPORT CIR SUITE 101
 CORONA, CA 92880

PHONE NUMBER / NUMBER / NUMBER / NUMBER / NUMBER:
 (877) 738-1729

MODEL / MODEL / MODEL:
 SF3

SERIAL NO. / NO. DE SERIE / N° DE SERIE:
 SF3A-4-21-06-123456

MADE IN CHINA / FABRIQUE EN CHINE / FABBRICATO IN CHINA

CONNECTING TO THE INSPIRE APP

Downloading the app

Depending on your smart device download our app through the App Store or Google Play.

Open the app and follow the instructions to setup an account.



MAINTENANCE

Warning

DO NOT place styrofoam or printed materials on the seat pads. Over time, these may stick to the pads and mar the surface.

DO NOT leave items sitting on the seat pads, these pads have a special density that takes shape to objects and small objects will leave imprints in the surface that may take time to come out.

- **Periodically inspect the cables for splitting, cracking or fraying. Also watch for bulging or flat areas in the cable.**
- **Immediately replace cables at the first signs of damage or wear. Never use equipment with damaged or worn cables.**
- **Cables naturally stretch over time, so check cable slack periodically and adjust cable tension as needed.**
- **Regularly inspect product for loose hardware.**
- **Do not use or store equipment outdoors.**
- **Inspect snap links, swivels, handles and weight stack pin for wear or damage. If wear or damage exists, replace with Inspire Fitness parts only.**
- **Locate and familiarize yourself with all warning decals on the Smith Machine Functional Trainer.**
- **Replace damaged or worn upholstery immediately.**
- **Periodically wipe down guide rods with a dry cloth and re-apply a thin coat of a Teflon™ based lubricant.**

WARRANTY

This Warranty applies to Inspire strength products manufactured or distributed by Inspire Fitness.

Inspire SF3 Warranty Periods

CONSUMER USE	
LIMITED LIFETIME FRAME	Includes Main Frame and Welds
LIMITED LIFETIME PARTS	Includes Upholstery, Hardware, etc.
LIMITED LIFETIME MOVING PARTS	Includes Pulleys, Cables, etc.

PLEASE NOTE THIS INSPIRE PRODUCT IS **NOT** MADE FOR COMMERCIAL USE

Using a non-commercial product in a commercial setting can result in serious injury or death!

Health In Motion warrants that the Product you have purchased for personal, family or household use from Health In Motion LLC or from an authorized Health In Motion reseller is free from defects in materials or workmanship under normal use during the warranty period. Your sales receipt, showing the date of purchase of the Product, is your proof of the date of purchase. This warranty extends only to you, the original purchaser. It is not transferable to anyone who subsequently purchases the Product from you. It excludes expendable parts such as paint and finish. This Warranty becomes VALID ONLY if the Product is assembled /installed according to the instructions / directions included with the Product.

Replacement and Repair of Parts

During the warranty period Health In Motion will, at no additional charge, repair or replace the Product if it becomes defective, malfunctions, or otherwise fails to conform with this Warranty under normal, personal, family, or household use. In repairing the product Health In Motion may replace defective parts with, at the option of Health In Motion, serviceable used parts that are equivalent to new parts in performance, or new parts. All exchanged parts and Products replaced under this warranty will become the property of Health In Motion. Health In Motion reserves the right to change manufacturers and or specification of any part to cover any existing warranty.

Service Procedures

To obtain warranty parts, you must return the parts to Health In Motion or an authorized Health In Motion retailer in its original container (or equivalent). You must pre-pay any shipping charges, taxes, or any other charges associated with transportation of the Product. In addition, you are responsible for insuring any Product shipped or returned. You assume the risk of loss during shipment. You must present Health In Motion with proof-of-purchase documents (including the date of purchase, Model, and Serial Number). Any evidence of alteration, erasing or forgery of proof -of-purchase documents will be cause to void this Warranty. Register your warranty online visit www.inspirefitness.com

What Is not covered by this Warranty:

Health in Motion LLC's sole obligation under this warranty is limited to the repair or replacement of parts, subject to the additions below. This warranty does not cover costs of removal, transportation, delivery or reinstallation. You are responsible for freight charges on warranty parts. Health in Motion LLC will accept parts covered under this warranty freight collect, provided that shipment has received prior approval.

Conditions and Exceptions

This Warranty does not extend to any Product not purchased from Health In Motion LLC or from an authorized Health In Motion reseller. This Warranty does not extend to any Product that has been damaged or rendered defective; (a) as a result of accident, misuse, or abuse; (b) by the use of parts not manufactured or sold by Health In Motion; (c) by modification of the Product; (d) as a result of service by anyone other than Health In Motion, or an authorized Health In Motion warranty service provider; (e) product that has not been properly maintained (follow maintenance schedule found on product). Should any product submitted for Warranty service be found to be ineligible, an estimate of repair cost will be furnished and the repair will be made if requested by you upon Health In Motion receipt of payment or acceptable arrangement of payment.

Disclaimer

EXCEPT AS EXPRESSLY SET FORTH IN THIS WARRANTY HEALTH IN MOTION MAKES NO OTHER WARRANTIES; EXPRESSED OR IMPLIED INCLUDING ANY IMPLIED WARRANTIES OF MERCHANTABILITY AND FITNESS FOR A PARTICULAR PURPOSE. HEALTH IN MOTION EXPRESSLY DISCLAIMS ALL WARRANTIES NOT STATED IN THIS WARRANTY. ANY IMPLIED WARRANTIES THAT MAY BE IMPOSED BY LAW ARE LIMITED TO THE TERMS OF THIS WARRANTY. NEITHER HEALTH IN MOTION NOR ANY OF ITS AFFILIATES SHALL BE RESPONSIBLE FOR INCIDENTAL OR CONSEQUENTIAL DAMAGES. HEALTH IN MOTION IS NOT RESPONSIBLE FOR THE REPAIR OR REPLACEMENT OF ANY PARTS THAT HEALTH IN MOTION DETERMINES HAVE BEEN SUBJECTED AFTER THE DATE OF MANUFACTURE TO ALTERATION, NEGLIGENCE, ABUSE, MISUSE, NORMAL WEAR & TEAR, ACCIDENT, DAMAGE DURING TRANSIT OR INSTALLATION, FIRE, FLOOD, OR ANY ACT OF GOD. SOME STATES DO NOT ALLOW LIMITATIONS ON HOW LONG AN IMPLIED WARRANTY LASTS OR THE EXCLUSION OR LIMITATION OF INCIDENTAL OR CONSEQUENTIAL DAMAGES, SO THE ABOVE LIMITATIONS OR EXCLUSION MAY NOT APPLY TO YOU. This Warranty gives you specific legal rights and you may also have other rights that may vary from state to state. This is the only express warranty applicable to Health In Motion's "Inspire" branded strength products. Health In Motion neither assumes nor authorizes anyone to assume for it any other express warranty.

AUSTRALIA: Our goods come with guarantees that cannot be excluded under the Australian Consumer Law. You are entitled to a replacement or refund for a major failure and for compensation for any other reasonably foreseeable loss or damage. You are also entitled to have the goods repaired or replaced if the goods fail to be of acceptable quality and the failure does not amount to a major failure.

EXPLODED VIEW

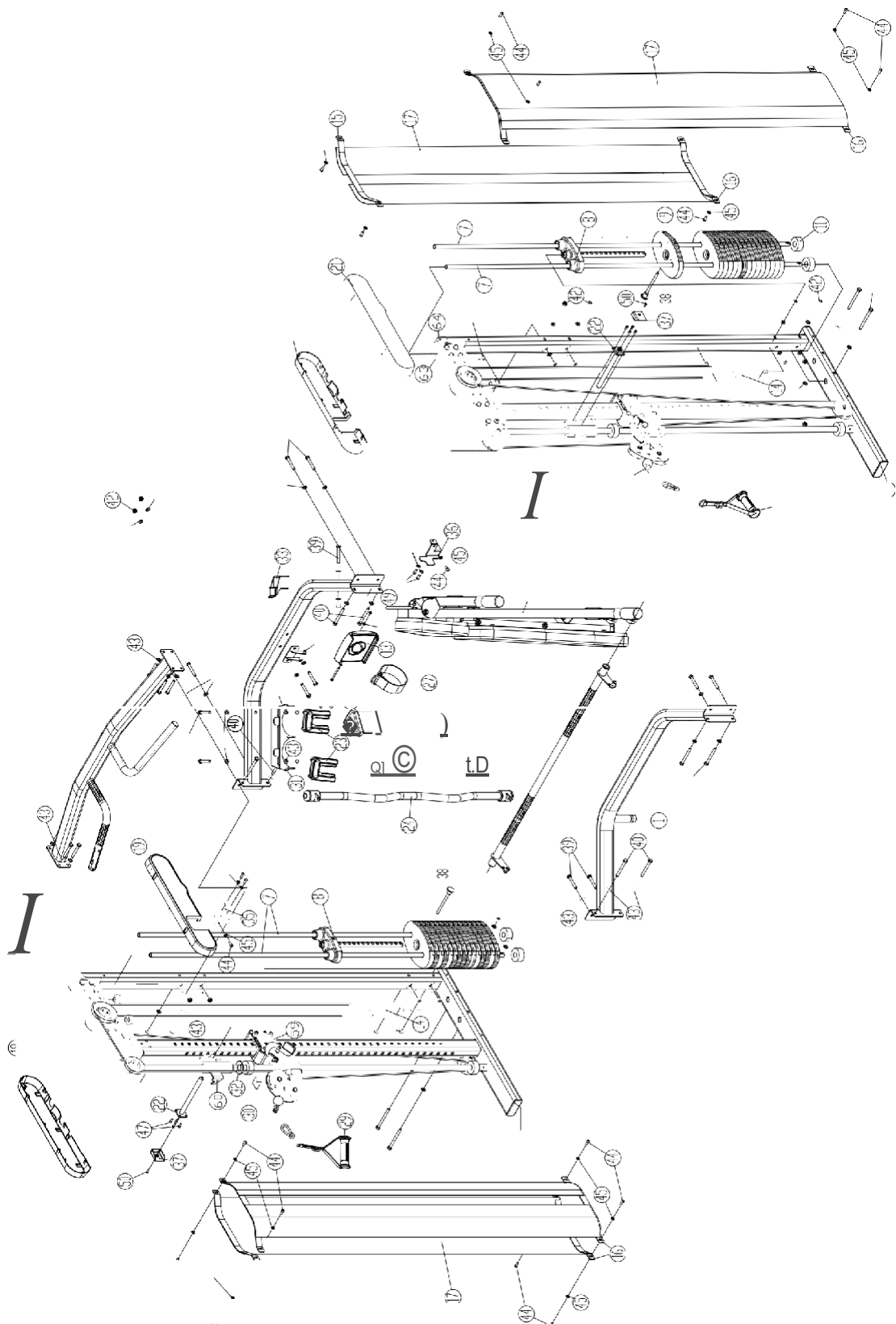

PARTS LISTS

No.	Description	Part Number	Qty.
1	GM697260001PZ01	Lower Crossbar	1
2	GM697260002PZ01	Upper Crossbar	1
3	GM697220001PZ01	Pull-up Crossbar	1
4	GM697320004PZ01	Smith Bar	1
5	GM697200001PZ01	Left Main Frame	1
6	GM697200002PZ01	Right Main Frame	1
7	GM697501001WX	Weight Stack Guide Rods	4
8	GM692500003PZ	Top Plate Assembly	2
9	GM692-500-009	Weight Stack Plate	30
10	GM692-881-002RC	Guide Rod Bushings	4
11	GM692-881-003RC	Rubber Bumpers	4
12	GM697260007PZ	Tablet Mount	1
13	BC423880109PZ03	Tablet Holder	1
14	GM697500004PZ04	Weight Stack Pulley	2
15	GM697321037PT0105	Top Shroud Plate	4
16	GM697321036PT0105	Bottom Shroud Plate	4
17	GM697-800-001RC	Wide, Medium and Narrow Shrouds	1
18	GM697-881-003RC	Outer Right Plastic Cover	1
19	GM697-881-004RC	Inner Right Plastic Cover	1
20	GM697-881-005RC	Inner Left Plastic Cover	1
21	GM697-881-006RC	Outer Left Plastic Cover	1
22	GM697320007PZ	Smith Bar Pin	2
23	GM692-500-001	5 Lbs. Add-On Weight	2
24	GM691320003PZ03	Dual Hook Curl Bar	1
25	GM692-881-011RC	Triceps Rope	1
26	GM692-400-005RC	Chin/Dip Belt	1
27	GM690-880-002RC	Ankle Strap	1
28	GM691-560-009	Spring Clip	2
29	GM870-880-007RCPZ	Single Handle	2
30	GM697500004PZ	Wire Rope Assembly	2
31	GM697260004PZ01	Accessory Rack	1
33	GM697260008PZ01	Bench Mount	1
34	GM692200507PZ01	FLB-2 Bench	1
35	GM697320008PZ01	Right Smith Bar Hook	1
36	GM697321018PZ	Left Smith Bar Hook	1
37	GM697881007RCPZ	Smith Bar End Caps	2
38	GM692500004PZ	Weight Pin	2
39	0111-010-758	M10x75mm Hex Bolt	21
40	0111-010-908	M10x90mm Hex Bolt	8
41	0111-010-058	M10x115mm Hex Bolt	4
42	0110-710-008	M10 Locknut	33
43	0116-010-008	M10 Flat Washer	66
44	0113-208-198	M8x20 Button Head Cap Screw	22
45	0116-008-028	M8 Washer	22
46	0113-206-751	M6x75mm Allen Head Cap Screw	1
47	0113-706-142	M6x14mm Allen Head Cap Screw	8
48	0116-006-019	M6 Washer	2
49	0110-706-019	M6 Locknut	1
50	0113-105-148	M5x14mm Phillips Head Screw	2
51	0511-608-002	8# Allen Tool	1
52	AB290-561-002	5#80°30, Multi Tool	1
53	M330-561-002	14# & 17# Hex Wrench	2
54	AB160561002XWX	10# Allen Tool	1
55	GM697-881-009	Cable Tie	6
56	GM697580000PZ	Hardware Pack 1	1
57	GM697580001PZ	Hardware Pack 2	1
58	GM697580002PZ	Hardware Pack 3	1
59	GM697320003PZ01	Right Carraige Assembly	1
60	GM697320006PZ	Right Smith Bar Slider	1
61	GM697320002PZ01	Left Carraige ssembly	1
62	GM697320005PZ	Left Smith Bar Slider	1
63	GM697-881-001RC	Inner trim cover R	2
64	GM697-881-002RC	Inner trim cover L	2



Model # FLB2C

USER MANUAL

FLB2C

FOLDING
ADJUSTABLE
BENCH



Record Serial Number Here

Health in Motion LLC
V03042022

IMPORTANT SAFETY NOTICE

PRECAUTIONS

This exercise bench is built for optimum safety. However, certain precautions apply whenever you use a piece of exercise equipment. Be sure to read the entire manual before you assemble or use your bench. In particular, note the following safety precautions:

1. Keep children and pets away from the bench at all times.
2. Only one person at a time should use the bench.
3. If the user experiences dizziness, nausea, chest pain, or any other abnormal symptoms, STOP the workout at once. Consult a physician.
4. Position the bench on a clear, leveled surface. Do not use outdoors.
5. Keep hands away from all moving parts.
6. Always wear appropriate workout clothing when exercising. Running or training shoes are also required when using the bench.
7. Use the bench only for its intended use as described in this manual.
8. Disabled persons should not use this bench without a qualified person or physician in attendance.
9. Always do stretching exercises to properly warm up before using this bench.
10. Never use this bench if it is not functioning properly.
11. A spotter is recommended during exercise.
12. Maximum **USER** weight on bench is 136 kg / 300 lb. This means that a **Person's** maximum weight can be up to 136 kg / 300 lb.

The total weight capacity that the bench can hold is 226.8 kg / 500 lb.

CARE AND MAINTENANCE

1. Regularly inspect product for loose hardware.
2. Do not use or store equipment outdoors.
3. Locate and familiarize yourself with all warning decals on the home gym.
4. Replace damaged or worn upholstery immediately.

REGISTER WARRANTY ONLINE

To register your product for warranty, visit inspirefitness.com/support.

BEFORE YOU BEGIN

Thank you for selecting the Inspire Fitness FLB2C. Service of your bench should only be performed by an authorized Inspire retailer. Service performed by anyone else can result in loss of warranty. For your safety and benefit, read this manual carefully before using the machine. As a manufacturer, we are committed to providing you complete customer satisfaction. If you have any questions, or find there are missing or damaged parts, please call our TOLL-FREE customer service number. Our Customer Service agents will provide immediate assistance to you.



Email

costcosupport@inspirefitness.com



Phone

+1 877-738-1729

Mon-Fri 8am-5pm PT - UTC-7h/8h



Chat

www.inspirefitness.com

Support is provided in English and Spanish

This bench is for adult use only. Do not let children play with the bench. Use caution while adjusting or working out on the bench.

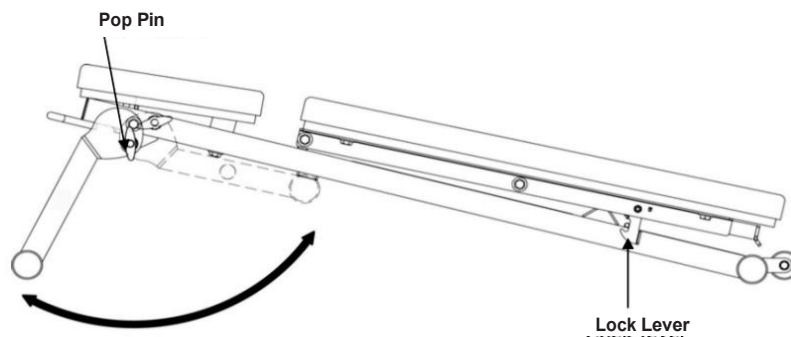

Pull pop pin to unfold or fold leg. Make sure hands are clear of pivot area. Make sure pop pin is fully engaged in locking holes after each adjustment.

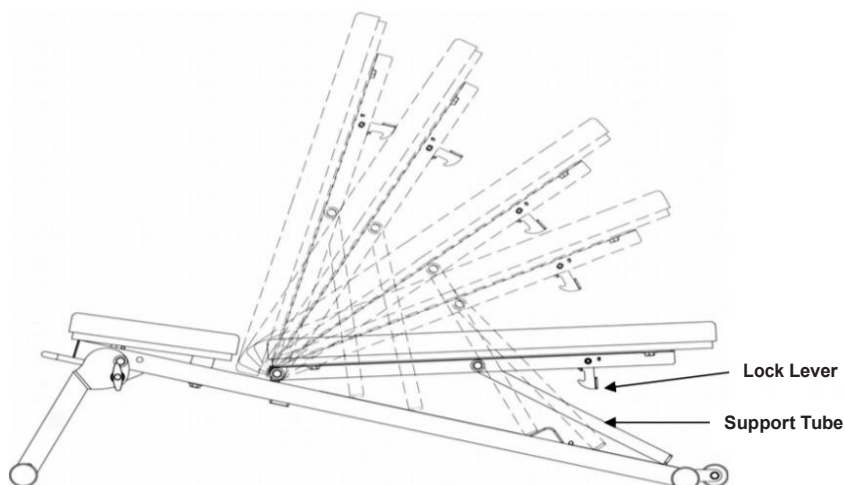

Swivel lock lever under pad to release back pad. Raise the head end of the pad so the free end of the support tube slips into a slot for a desired position. Before use, make sure the support tube is secure in a slot.

When folding the bench flat, keep hands clear of any pivot areas or closing areas. Make sure the lock lever is locked over catch pin before moving.

WARRANTY

This Warranty applies to Inspire strength products manufactured or distributed by Inspire Fitness.

Inspire FLB2C Warranty Periods

CONSUMER USE	
LIMITED LIFETIME FRAME	Includes Main Frame and Welds
LIMITED LIFETIME PARTS	Includes Upholstery, Hardware, etc.
LIMITED LIFETIME MOVING PARTS	Includes Pulleys, Cables, etc.

PLEASE NOTE THIS INSPIRE PRODUCT IS **NOT** MADE FOR COMMERCIAL USE

Using a non-commercial product in a commercial setting can result in serious injury or death!

Health In Motion warrants that the Product you have purchased for personal, family or household use from Health In Motion LLC or from an authorized Health In Motion reseller is free from defects in materials or workmanship under normal use during the warranty period. Your sales receipt, showing the date of purchase of the Product, is your proof of the date of purchase. This warranty extends only to you, the original purchaser. It is not transferable to anyone who subsequently purchases the Product from you. It excludes expendable parts such as paint and finish. This Warranty becomes VALID ONLY if the Product is assembled /installed according to the instructions / directions included with the Product.

Replacement and Repair of Parts

During the warranty period Health In Motion will, at no additional charge, repair or replace the Product if it becomes defective, malfunctions, or otherwise fails to conform with this Warranty under normal, personal, family, or household use. In repairing the product Health In Motion may replace defective parts with, at the option of Health In Motion, serviceable used parts that are equivalent to new parts in performance, or new parts. All exchanged parts and Products replaced under this warranty will become the property of Health In Motion. Health In Motion reserves the right to change manufacturers and or specification of any part to cover any existing warranty.

Service Procedures

To obtain warranty parts, you must return the parts to Health In Motion or an authorized Health In Motion retailer in its original container (or equivalent). You must pre-pay any shipping charges, taxes, or any other charges associated with transportation of the Product. In addition, you are responsible for insuring any Product shipped or returned. You assume the risk of loss during shipment. You must present Health In Motion with proof-of-purchase documents (including the date of purchase, Model, and Serial Number). Any evidence of alteration, erasing or forgery of proof-of-purchase documents will be cause to void this Warranty. Register your warranty online visit www.inspirefitness.com

What Is not covered by this Warranty:

Health in Motion LLC's sole obligation under this warranty is limited to the repair or replacement of parts, subject to the additions below. This warranty does not cover costs of removal, transportation, delivery or reinstallation. You are responsible for freight charges on warranty parts. Health in Motion LLC will accept parts covered under this warranty freight collect, provided that shipment has received prior approval.

Conditions and Exceptions

This Warranty does not extend to any Product not purchased from Health In Motion LLC or from an authorized Health In Motion reseller. This Warranty does not extend to any Product that has been damaged or rendered defective; (a) as a result of accident, misuse, or abuse; (b) by the use of parts not manufactured or sold by Health In Motion; (c) by modification of the Product; (d) as a result of service by anyone other than Health In Motion, or an authorized Health In Motion warranty service provider; (e) product that has not been properly maintained (follow maintenance schedule found on product). Should any product submitted for Warranty service be found to be ineligible, an estimate of repair cost will be furnished and the repair will be made if requested by you upon Health In Motion receipt of payment or acceptable arrangement of payment.

Disclaimer

EXCEPT AS EXPRESSLY SET FORTH IN THIS WARRANTY HEALTH IN MOTION MAKES NO OTHER WARRANTIES; EXPRESSED OR IMPLIED INCLUDING ANY IMPLIED WARRANTIES OF MERCHANTABILITY AND FITNESS FOR A PARTICULAR PURPOSE. HEALTH IN MOTION EXPRESSLY DISCLAIMS ALL WARRANTIES NOT STATED IN THIS WARRANTY. ANY IMPLIED WARRANTIES THAT MAY BE IMPOSED BY LAW ARE LIMITED TO THE TERMS OF THIS WARRANTY. NEITHER HEALTH IN MOTION NOR ANY OF ITS AFFILIATES SHALL BE RESPONSIBLE FOR INCIDENTAL OR CONSEQUENTIAL DAMAGES. HEALTH IN MOTION IS NOT RESPONSIBLE FOR THE REPAIR OR REPLACEMENT OF ANY PARTS THAT HEALTH IN MOTION DETERMINES HAVE BEEN SUBJECTED AFTER THE DATE OF MANUFACTURE TO ALTERATION, NEGLIGENCE, ABUSE, MISUSE, NORMAL WEAR & TEAR, ACCIDENT, DAMAGE DURING TRANSIT OR INSTALLATION, FIRE, FLOOD, OR ANY ACT OF GOD. SOME STATES DO NOT ALLOW LIMITATIONS ON HOW LONG AN IMPLIED WARRANTY LASTS OR THE EXCLUSION OR LIMITATION OF INCIDENTAL OR CONSEQUENTIAL DAMAGES, SO THE ABOVE LIMITATIONS OR EXCLUSION MAY NOT APPLY TO YOU. This Warranty gives you specific legal rights and you may also have other rights that may vary from state to state. This is the only express warranty applicable to Health In Motion's "Inspire" branded strength products. Health In Motion neither assumes nor authorizes anyone to assume for it any other express warranty.

AUSTRALIA: Our goods come with guarantees that cannot be excluded under the Australian Consumer Law. You are entitled to a replacement or refund for a major failure and for compensation for any other reasonably foreseeable loss or damage. You are also entitled to have the goods repaired or replaced if the goods fail to be of acceptable quality and the failure does not amount to a major failure.



www.inspirefitness.com